

FUNCTION GENERATOR KIT

MODEL FG-600K



Assembly and Instruction Manual

ELENCO®

PARTS LIST

If any parts are missing or damaged, see instructor or bookstore. **DO NOT** contact your place of purchase as they will not be able to help you. Contact ELENCO® (address/phone/e-mail is at the back of this manual) for additional assistance, if needed.

RESISTORS

Qty.	Symbol	Description	Part #
☐ 1	R2	10kΩ Potentiometer	192531
☐ 1	R3	100kΩ Potentiometer	192612
☐ 1	R6 (201)	Resistor chip 200Ω 5% 1/8W	196320
☐ 1	R1 (621)	Resistor chip 620Ω 5% 1/8W	196362
☐ 1	R5 (392)	Resistor chip 3.9kΩ 5% 1/8W	196434
☐ 1	R7 (822)	Resistor chip 8.2kΩ 5% 1/8W	196484
☐ 1	R8 (103)	Resistor chip 10kΩ 5% 1/8W	196514
☐ 1	R4 (223)	Resistor chip 22kΩ 5% 1/8W	196522
☐ 1	R9 (104)	Resistor chip 100kΩ 5% 1/8W	196614

CAPACITORS

Qty.	Symbol	Value	Description	Part #
☐ 1	C6	820pF	Capacitor chip	228297
☐ 1	C5	.01μF	Capacitor chip	241095
☐ 1	C4	.1μF	Capacitor chip	250195
☐ 1	C3	1μF	Electrolytic chip	260127
☐ 3	C2, C7, C8	10μF	Electrolytic chip	271024
☐ 1	C1	100μF 16V	Electrolytic radial	281044
☐ 1	C9	1000μF 16V	Electrolytic radial	291044

SEMICONDUCTORS

Qty.	Symbol	Value	Description	Part #
☐ 1	U1	XR-2206	Integrated Circuit Surface Mount	332206SM

MISCELLANEOUS

Qty.	Description	Part #	Qty.	Description	Part #
☐ 1	PC board FG-600	511002	☐ 2	Binding post green	625033
☐ 2	Switch slide PC mount (S2, S3)	541009	☐ 4	Screw 4-40 x 1/4" phillips black	641433
☐ 1	Switch rotary 2p 6 pos. (S1)	542207	☐ 3	7mm Hex pot nut	644101
☐ 1	Battery snap 9V	590098	☐ 1	9mm Hex switch nut	644102
☐ 1	Top panel	614109	☐ 2	8mm x 14mm Flat washer	645101
☐ 3	Knob	622009	☐ 1	9mm x 15mm Flat washer	645103
☐ 1	Case black plastic	623003	☐ 1	Handle	666600
☐ 2	Spacer 5/8"	624432	☐ 2"	Weather strip	790007
☐ 1	Binding post black	625031	☐ 12"	Wire 22ga. black solid	814120
☐ 3	Hex nut for binding post	625031HN	☐ 1	Solder - lead-free	9LF99
☐ 3	Lockwasher binding post	625031LW			

PARTS IDENTIFICATION

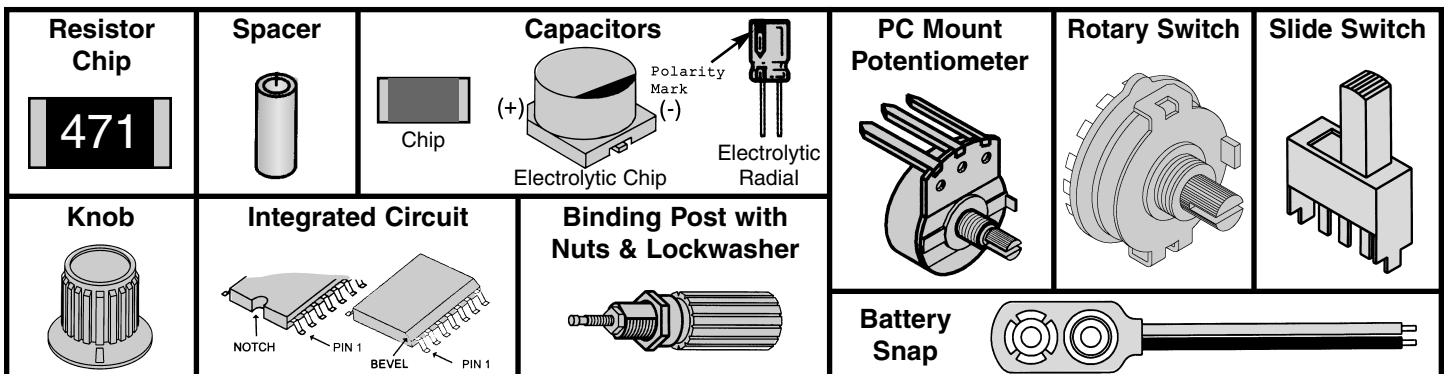

INTRODUCTION

Assembly of your FG-600 Function Generator will prove to be an exciting project and give much satisfaction and personal achievement. The FG-600 contains a complete function generator capable of producing sine, square and triangle wave forms. The frequency of this generator can be continuously varied from 1Hz to 1MHz in 6 steps. A fine frequency control makes selection of any frequency in between easy. The amplitude of the wave forms are adjustable from 0 to 3Vpp. This complete function generator system is suitable for experimentation and applications by the student. The entire function generator is comprised of a single XR-2206 monolithic IC and a limited number of passive circuit components.

The FG-600 uses surface mounted components. By building this kit, you will obtain an interesting electronic device and also gain valuable experience in surface mount technology.

SPECIFICATIONS

OUTPUT:

- Waveforms: Sine, Triangle, Square
- Impedance: $600\Omega \pm 10\%$.
- Frequency: 1Hz - 1MHz in 6 decade steps with variable ranges.

SINE WAVE:

- Amplitude: 0 - 3Vpp.
- Distortion: Less than 1% (at 1kHz).
- Flatness: $\pm 0.05\text{dB}$ 1Hz - 100kHz.

SQUARE WAVE:

- Amplitude: 8V (no load).
- Rise Time: Less than 50ns (at 1kHz).
- Fall Time: Less than 30ns (at 1kHz).
- Symmetry: Less than 5% (at 1kHz).

TRIANGLE WAVE:

- Amplitude: 0 - 3Vpp.
- Linearity: Less than 1% (up to 100kHz).

POWER REQUIREMENTS:

- Standard 9V Battery

OPERATING TEMPERATURE:

- 0°C TO 50°C.

PARTS VERIFICATION

Before beginning the assembly process, familiarize yourself with the components and this instruction book. Verify that all parts are present. This is best done by checking off each item against the parts list.

Care must be taken when handling the chip resistors and capacitors. They are very small and are easily lost. Chip resistors are marked with their component value. The first 2 digits are the first 2 digits of the resistance in ohms. The last digit gives the number of zeros following the first 2 digits. The resistor shown at right is therefore 3900Ω .

The values of the chip capacitors are not marked on the component. The chip capacitor C6 (820pF) is in the bag with the chip resistors, the chip capacitor C5 (.01 μF) is in the bag with the electrolytic capacitors and the chip capacitor C4 (.1 μF) is in the bag with the IC. To avoid mixing these parts up, they should not be taken out of their packages until just before they are soldered to the PC board.

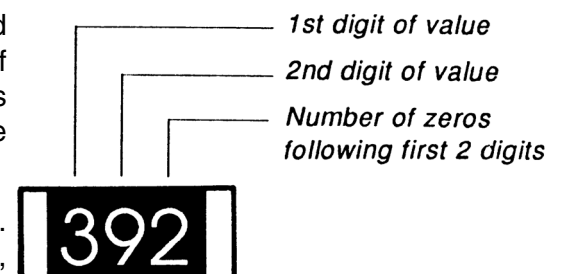

CONSTRUCTION

Introduction

The most important factor in assembling your FG-600 Function Generator Kit is good soldering techniques. Using the proper soldering iron is of prime importance. A small pencil type soldering iron of 25 - 40 watts is recommended. **The tip of the iron must be kept clean at all times and well-tinned.**

Solder

For many years leaded solder was the most common type of solder used by the electronics industry, but it is now being replaced by lead-free solder for health reasons. This kit contains lead-free solder, which contains 99.3% tin, 0.7% copper, and has a rosin-flux core.

Lead-free solder is different from lead solder: It has a higher melting point than lead solder, so you need higher temperature for the solder to flow properly. Recommended tip temperature is approximately 700°F; higher temperatures improve solder flow but accelerate tip decay. An increase in soldering time may be required to achieve good results. Soldering iron tips wear out faster since lead-free solders are more corrosive and the higher soldering temperatures accelerate corrosion, so proper tip care is important. The solder joint finish will look slightly duller with lead-free solders.

Use these procedures to increase the life of your soldering iron tip when using lead-free solder:

- Keep the iron tinned at all times.
- Use the correct tip size for best heat transfer. The conical tip is the most commonly used.

- Turn off iron when not in use or reduce temperature setting when using a soldering station.
- Tips should be cleaned frequently to remove oxidation before it becomes impossible to remove. Use Dry Tip Cleaner (Elenco® #SH-1025) or Tip Cleaner (Elenco® #TTC1). If you use a sponge to clean your tip, then use distilled water (tap water has impurities that accelerate corrosion).

Safety Procedures

- **Always wear safety glasses or safety goggles to protect your eyes when working with tools or soldering iron, and during all phases of testing.** 
- Be sure there is **adequate ventilation** when soldering.
- Locate soldering iron in an area where you do not have to go around it or reach over it. Keep it in a safe area away from the reach of children.
- **Do not hold solder in your mouth.** Solder is a toxic substance. Wash hands thoroughly after handling solder.

Assemble Components

In all of the following assembly steps, the components must be installed on the top side of the PC board unless otherwise indicated. The top legend shows where each component goes. The leads pass through the corresponding holes in the board and are soldered on the foil side.

Use only rosin core solder.

DO NOT USE ACID CORE SOLDER!

What Good Soldering Looks Like

A good solder connection should be bright, shiny, smooth, and uniformly flowed over all surfaces.

1. Solder all components from the copper foil side only. Push the soldering iron tip against both the lead and the circuit board foil.

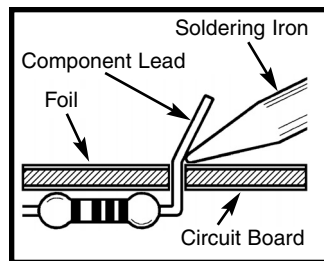

2. Apply a small amount of solder to the iron tip. This allows the heat to leave the iron and onto the foil. Immediately apply solder to the opposite side of the connection, away from the iron. Allow the heated component and the circuit foil to melt the solder.

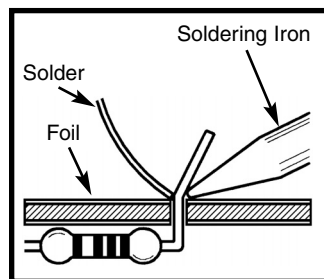

3. Allow the solder to flow around the connection. Then, remove the solder and the iron and let the connection cool. The solder should have flowed smoothly and not lump around the wire lead.

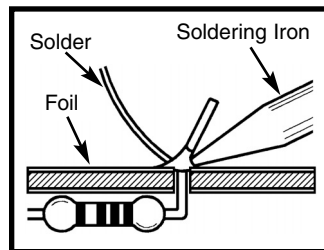

4. Here is what a good solder connection looks like.

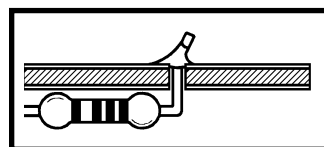

Types of Poor Soldering Connections

1. **Insufficient heat** - the solder will not flow onto the lead as shown.

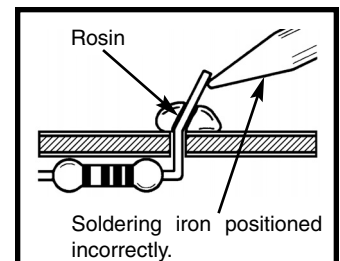

2. **Insufficient solder** - let the solder flow over the connection until it is covered. Use just enough solder to cover the connection.

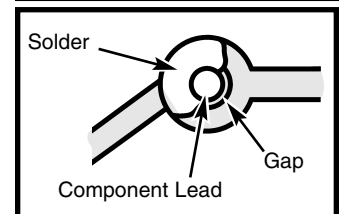

3. **Excessive solder** - could make connections that you did not intend to between adjacent foil areas or terminals.

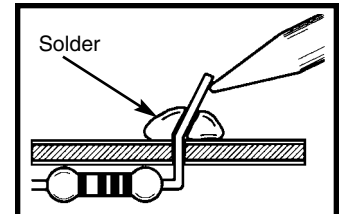

4. **Solder bridges** - occur when solder runs between circuit paths and creates a short circuit. This is usually caused by using too much solder. To correct this, simply drag your soldering iron across the solder bridge as shown.

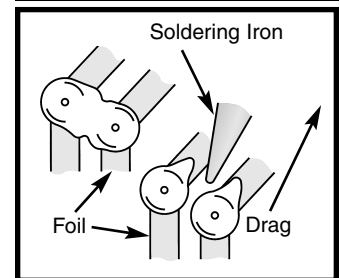

Assemble Surface Mount Components

The most important factor in assembling your FG-600 Function Generator Kit is good soldering techniques. Using the proper soldering iron is of prime importance. A small pencil type iron of 10-15 watts is recommended. A sharply pointed tip is essential when soldering surface mount components. The tip of the iron should be kept clean and well tinned at all times. Many areas on the printed circuit board are close together and care must be given not to form solder shorts. Solder shorts may occur if you accidentally touch an adjacent foil, particularly a previously soldered connection, using too much solder, or dragging the iron across adjacent foils. If a solder short occurs, remove it with your hot iron. Use only rosin core solder. Before soldering the FG-600 board should be taped to the workbench to keep it from moving when touched with the soldering iron. For a good soldering job, the areas being soldered must be heated sufficiently so that the solder flows freely. When soldering surface mount resistors and capacitors, the following procedure may be used:

1. Using tweezers, place the surface mount component on the PC board pads and secure in place with tape.
2. Apply a small amount of solder to the soldering iron tip. This allows the heat to leave the iron and flow onto the foil.
3. Place the iron in contact with the PC board foil. Apply a small amount of solder simultaneously to the foil and the component and allow them to melt the solder.
4. Remove the iron and allow the solder to cool. The solder should have flowed freely and not lump up around the component.
5. Remove the tape and solder the other side of the component.

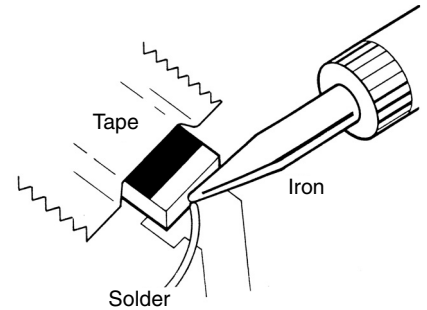

When soldering the transistors, diodes and integrated circuits, the following procedure may be used:

1. Place the component on the PC board pads and secure in place with tape.
2. Apply a small amount of solder to the soldering iron tip.
3. Place the soldering iron tip on top of the component lead to be soldered and apply solder simultaneously to the lead and the PC board foil.
4. Remove the iron and allow the solder to cool. The solder should have flowed freely and not lump up around the component.

After a component is completely soldered, each solder joint should be inspected with a magnifying glass. If the solder has not flowed smoothly, a bad solder joint is indicated. This occurs when the component and pad have not been heated sufficiently. To correct, reheat the connection and if necessary add a small amount of additional solder.

Another way to solder surface mount components is as follows:

1. Apply a small amount of solder to the soldering iron tip.
2. Using tweezers, hold the component on the PC board pads.
3. Apply the soldering iron simultaneously to the component and pad and allow the solder to flow around the component.
4. Remove the soldering iron and allow the connection to cool.

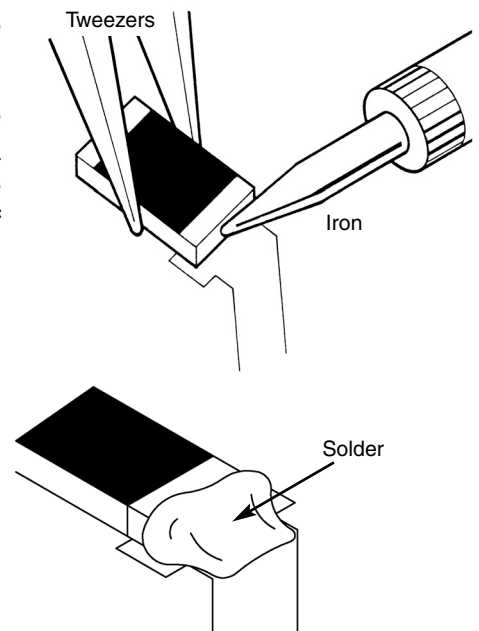

ASSEMBLE COMPONENTS TO THE PC BOARD

Care must be given to identifying the proper components and in good soldering habits. Refer to the soldering tips section in this manual before you begin installing the components. Place a check mark in the box after each step is complete.

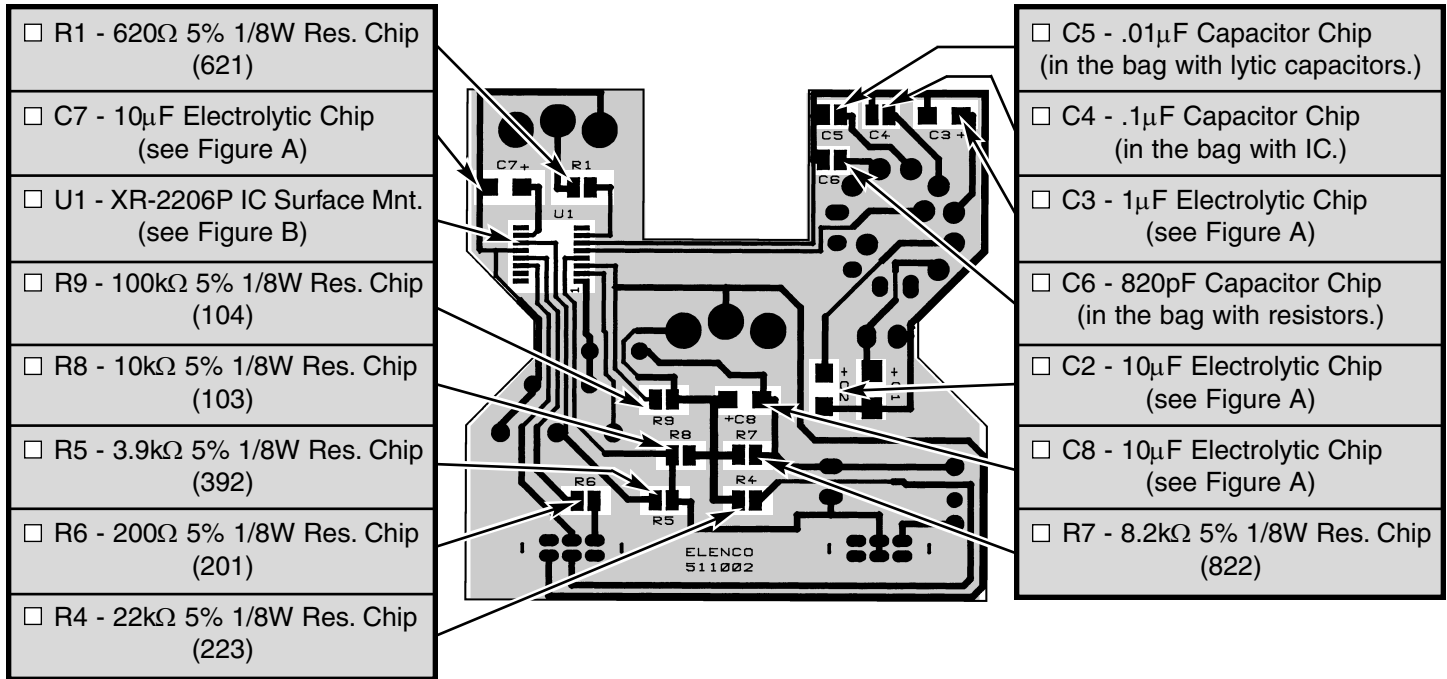
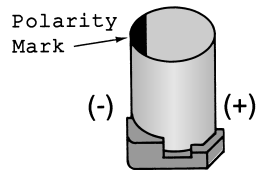

Figure A

This capacitor is polarized, be sure that the (+) and (-) sides are positioned correctly.



Warning: If the capacitor is connected with incorrect polarity, it may heat up and either leak or cause the capacitor to explode.

Figure B

Mount IC with pin 1 as shown on the PC board illustration.

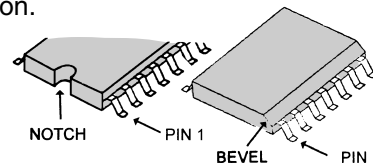

ASSEMBLE COMPONENTS TO THE PC BOARD

- S1 - 6 position Rotary Switch (see Figure C)
- C1 - 100 μ F 16V Electrolytic (see Figure D)
- C9 - 1000 μ F 16V Electrolytic (see Figure D)
- BT - Battery Snap (see Figure F)
- S3 - Slide Switch

- R3 - 100k Ω Pot PC Mount (see Figure E)
- R2 - 10k Ω Pot PC Mount
 7mm Hex Pot Nut (see Figure E)
- Jumper Wire
 Jumper Wire (see Figure G)
- J1 - 3" Black Wire
 J2 - 3" Black Wire
 J3 - 3" Black Wire (see Figure H)
- S2 - Slide Switch

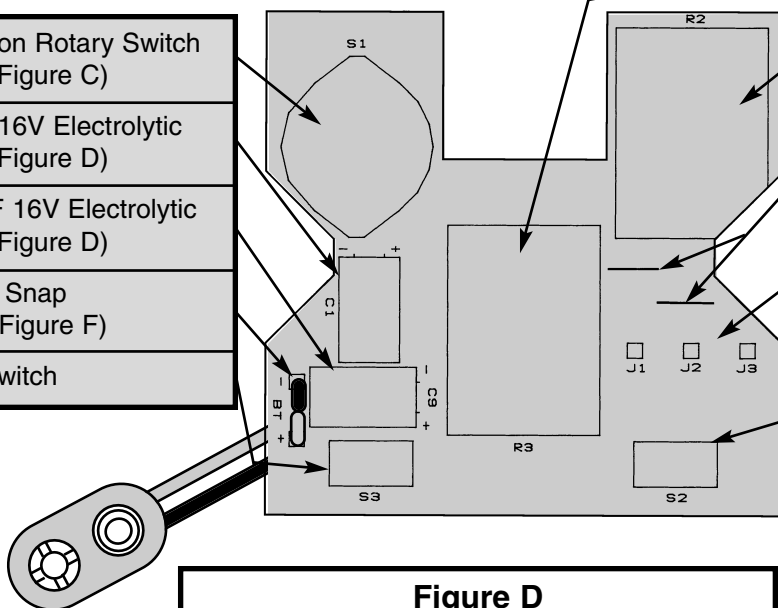

Figure D

Electrolytic capacitors have polarity. Be sure to mount them with the negative (-) lead (marked on side) in the correct hole. Bend the electrolytic capacitors as shown.

Warning: If the capacitor is connected with incorrect polarity, it may heat up and either leak or cause the capacitor to explode.

Figure C

Mount down flush with PC board.

Figure E

Mount the pots down flush with the PC board. For R2, install nut.

Figure G

Form a discarded piece of an electrolytic lead into a jumper wire by bending the wire into the correct length and mounting it to the PC board.

Figure F

Thread the battery snap wires through the hole in the PC board from the solder side as shown. Solder the red wire to the BT+ point and the black wire to the BT- point on the PC board.

Figure H

Cut three 3" wires and strip 1/4" of insulation off of both ends of the wires. Solder these wires to the points J1, J2 and J3.

- ❑ Install the colored binding posts to the panel as shown in Figure I. Use the hardware shown in the figure.

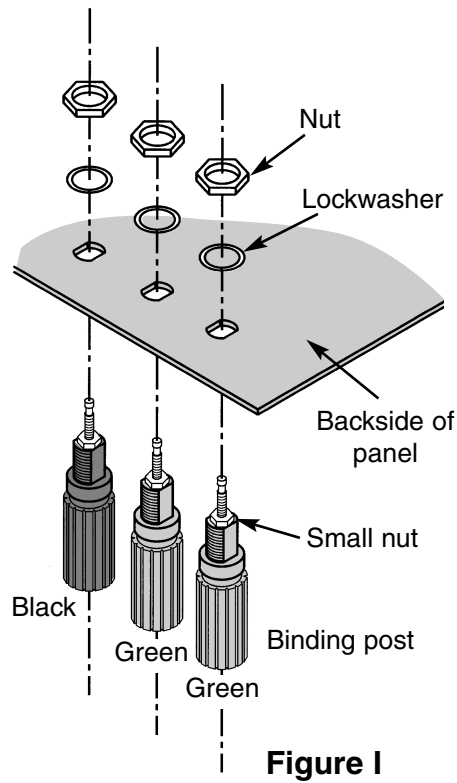

WIRING

- ❑ Attach the 3" black wire from point J3 on the PC board, to the black binding post, then solder into place (see Figure J).
- ❑ Attach the 3" black wire from point J2 on the PC board, to the middle green binding post, then solder into place (see Figure J).
- ❑ Attach the 3" black wire from point J1 on the PC board, to the other green binding post, then solder into place (see Figure J).

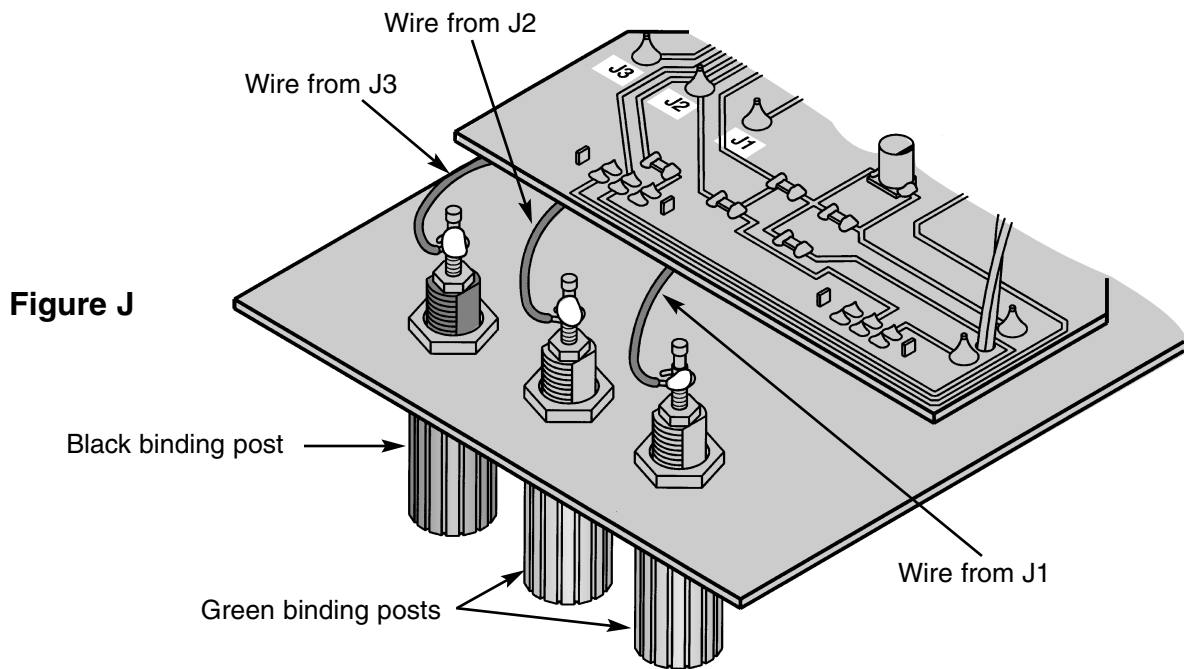

FINAL ASSEMBLY

- Place the washers onto their locations as shown in Figure K, being careful to check the sizes. Then, tighten the hex nuts onto the potentiometers noting their size as shown in Figure K. Finally, fasten the spacers onto the top panel with two 4-40 x 1/4" black screws.

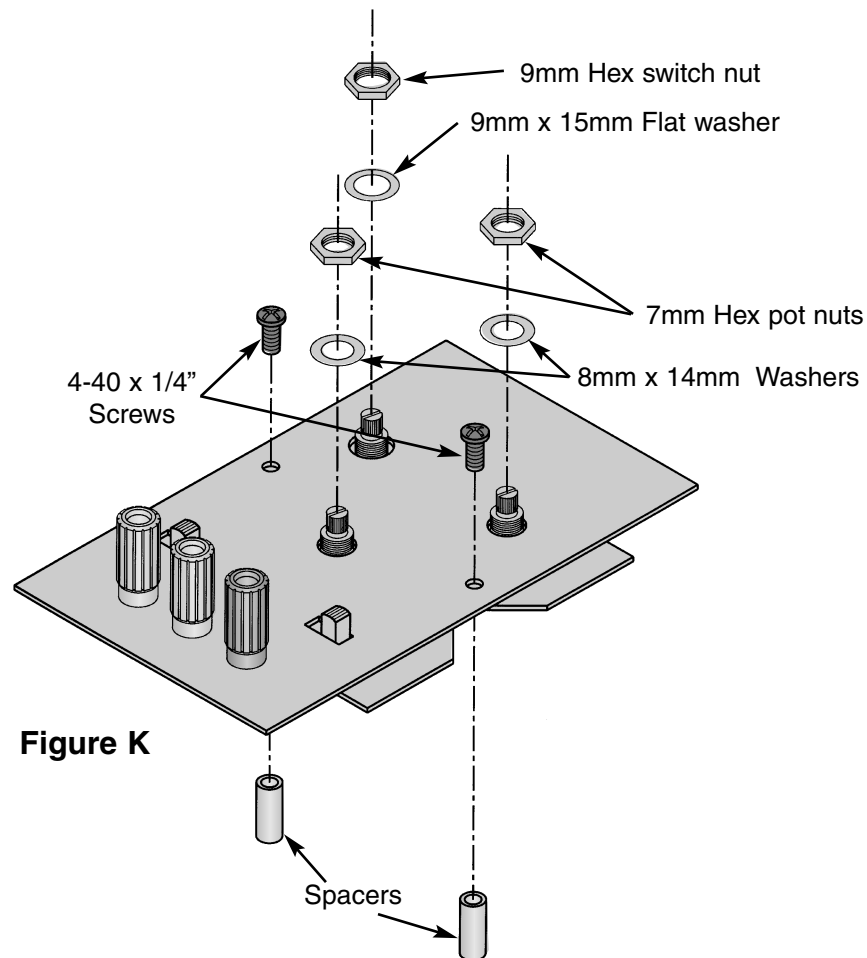

- Install the handle as shown in Figure L.
- Cut two pieces of weather stripping. Remove the protective backing and place a piece of weather strip on the top panel in the location shown in Figure L. Then, place the other piece on the case in the location shown.

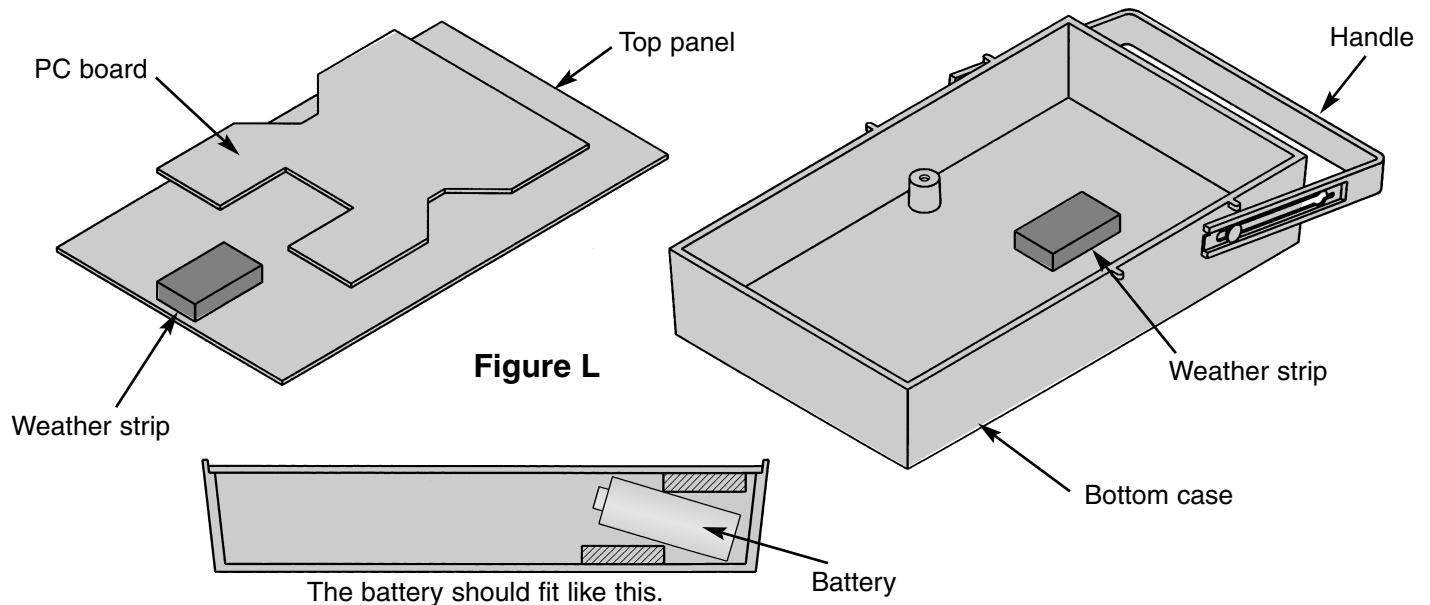

- ❑ Attach the battery snap to the battery. Insert the PC board assembly with the panel and battery into the case (as shown in Figure L). Insert two 4-40 x 1/4" screws into the bottom case in positions shown in Figure M and tighten in place.
- ❑ Turn the shafts on the two potentiometers and rotary switch fully counter-clockwise. Push the three knobs onto the shafts so that the line on the knob is on the point as shown in Figure N.

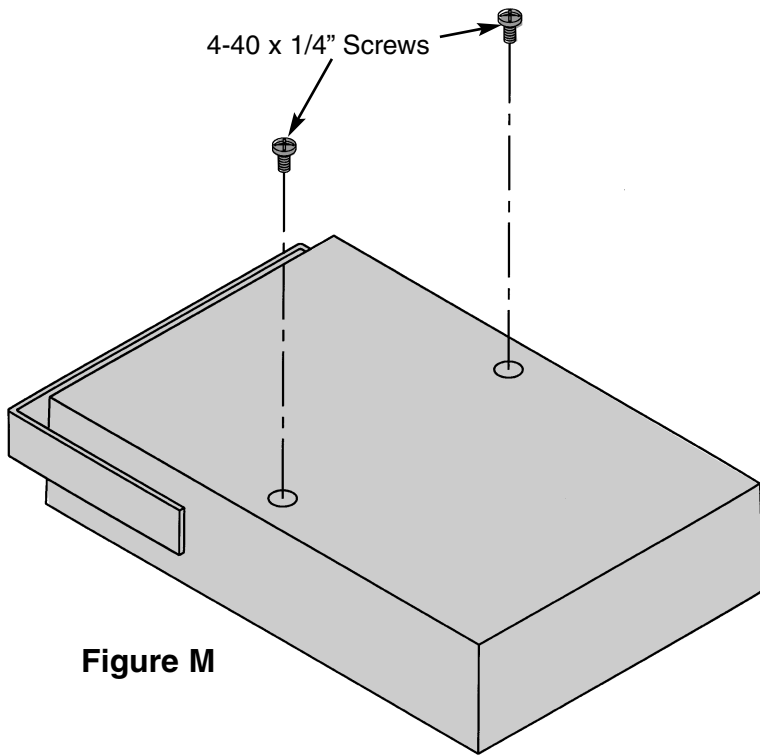

Figure M

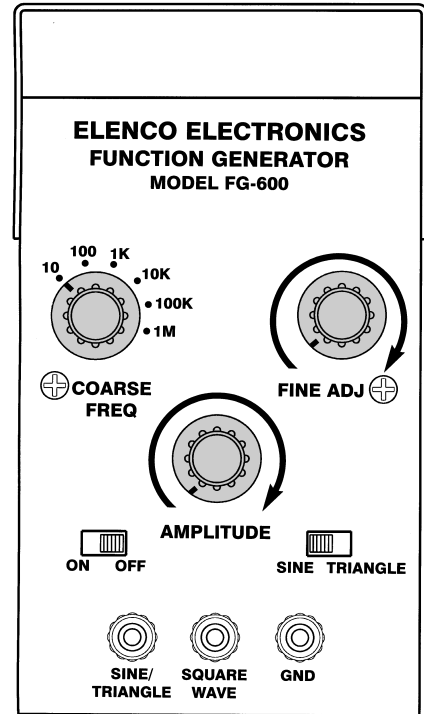

Figure N

TESTING THE FG-600 FUNCTION GENERATOR

The unit may be tested by following the 4 steps listed below. Should any of these tests fail, refer to the Troubleshooting Guide.

1) Set the switches and pots as follows:

On/Off	On
Range	10
Frequency	Maximum (clockwise)
Amplitude	Maximum (clockwise)
Sine/Triangle	Set Sine/Triangle switch to Sine position

In each of the following steps, start with the switch and pots as shown on the previous page.

2) OUTPUT WAVEFORMS

Connect an oscilloscope probe to the square wave output. You should see about 8V peak to peak square wave of a little over 15Hz. Connect the oscilloscope probe to the sine/triangle wave output. You should see a sine wave of approximately 3V peak to peak or greater. Set the Sine/Triangle switch to the Triangle wave position. You should see a triangle waveform of approximately 3V peak to peak or greater. In both sine and triangle waves, the frequency is also a little over 15Hz.

3) FREQUENCY CONTROLS

6 range settings, vary the FREQUENCY pot from max to min and check that the frequency varies according to Table 1 on page 12 or greater.

4) AMPLITUDE CONTROLS

Set the switch and pots as in Step 1. Connect the oscilloscope to the sine/triangle wave output and vary the AMPLITUDE pot. The sine wave amplitude should vary from near zero to approximately 3V peak to peak or greater.

TROUBLESHOOTING GUIDE

A) NO SINE/TRIANGLE OR SQUARE WAVE OUTPUT

- 1) Check the soldering on switch S3.
- 2) Check the soldering on IC U1.
- 3) Check for +9V on IC1 pin 4.
- 4) Check that U1 is not installed backwards.
- 5) Check all of the values and soldering on R1, R2, R3, R4, R5, R7, R8, R9, C8, and C9.

B) WRONG FREQUENCY ON ANY RANGE SETTING

- 1) This indicates a wrong value capacitor in the bad range position.

C) SINE/TRIANGLE SWITCH DOESN'T WORK

- 1) Check the soldering on switch S2 and R6.
- 2) Check the value of R6.

D) AMPLITUDE CONTROL DOESN'T WORK

- 1) Check the soldering on R3, R7, R8, R4 and R9.
- 2) Check the values of the above mentioned components.

E) FREQUENCY CONTROL DOESN'T WORK

- 1) Check the soldering on R1 and R2.
- 2) Check the values of the above two resistors.

FUNCTIONAL DESCRIPTION

The FG-600 is a function generator integrated circuit capable of producing high quality sine, triangle, and square waves of high stability and accuracy. A picture of each waveform is shown below:

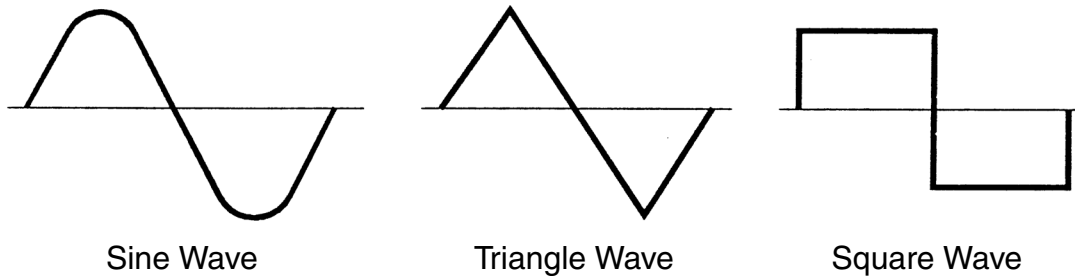

THEORY OF OPERATION

The heart of the FG-600 Function Generator is the XR-2206 monolithic function generator integrated circuit. The XR-2206 is comprised of four main functional blocks as shown in the functional block diagram (Figure 1). They are:

- A Voltage Controlled Oscillator (VCO)
- An Analog Multiplier and Sine-shaper
- Unity Gain Buffer Amplifier
- A set of current switches

The VCO actually produces an output frequency proportional to an input current, which is produced by a resistor from the timing terminals to ground. The current switches route one of the currents to the VCO to produce an output frequency. Which timing pin current is used, is controlled by the FSK input (pin 9). In the FG-600, the FSK input is left open, thus only the resistor on pin 7 is used. The frequency is determined by this formula:

$$f_o = 1/RC \text{ Hz}$$

where f_o is the frequency in Hertz
 R is the resistance at pin 7 in Ohms
 C is the capacitance across pin 5 and 6 in Farads

Note that frequency is inversely proportional to the value of RC. That is, the higher the value of RC, the smaller the frequency.

The resistance between pins 13 and 14 determine the shape of the output wave on pin 2. No resistor produces a triangle wave. A 200Ω resistor produces a sine wave.

FUNCTIONAL BLOCK DIAGRAM

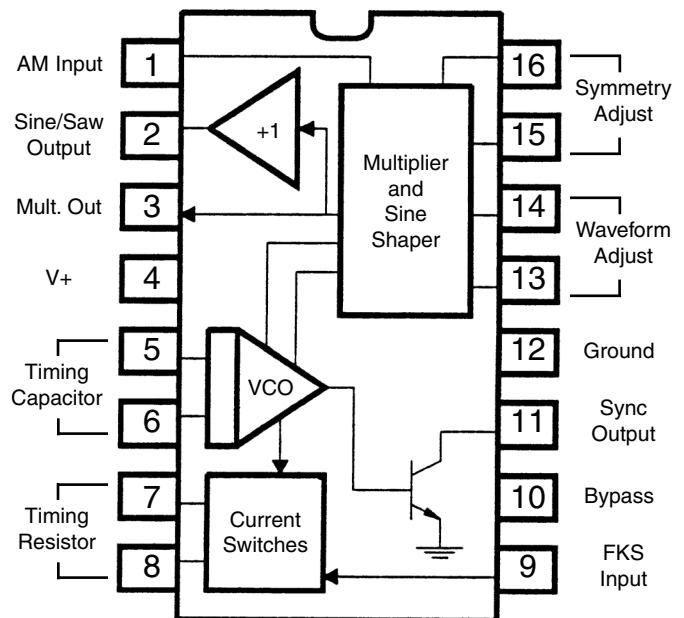

Figure 1

CONTROLS

RANGE SWITCHES

Six ranges of frequency are provided by the range switch as shown in Table 1.

POSITION	TYPICAL FREQUENCY RANGE
1	1Hz - 15Hz
2	10Hz - 150Hz
3	100Hz - 1.5kHz
4	1kHz - 15kHz
5	10kHz - 150kHz
6	100kHz - 1MHz

Table 1

SINE/TRIANGLE SWITCH

This SINE/TRIANGLE Switch selects the waveform, sine wave or triangle wave, sent to the SINE/TRIANGLE output terminal.

FREQUENCY MULTIPLIER

The multiplier is a variable control allowing frequency settings between fixed ranges. The ranges are as shown in Table 1.

AMPLITUDE CONTROL

The Amplitude Control provides amplitude adjustment from near 0 to 3V or greater for both sine and triangle waveforms.

ON/OFF SWITCH

The ON/OFF Switch turns the power to the FG-600 on or off.

OUTPUT TERMINAL

The output marked SINE/TRIANGLE provides the sine and triangle waveforms. The output marked SQUARE WAVE provides the square wave. The output marked GND provides the ground for all output waveforms.

SCHEMATIC DIAGRAM

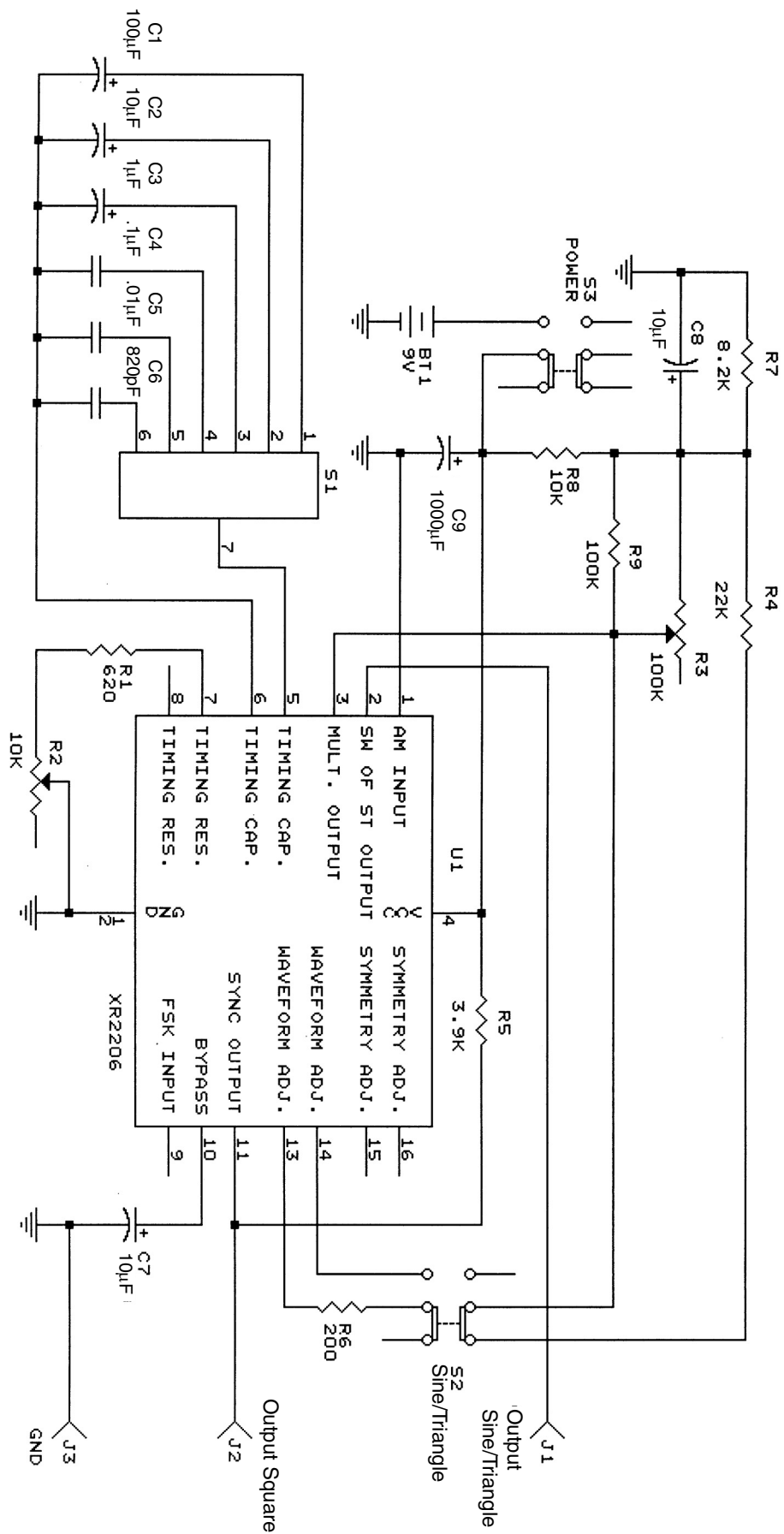

QUIZ

- 1) The heart of the FG-600 Function Generator is the _____ monolithic function generator integrated circuit.
- 2) The XR-2206 is comprised of four main blocks. They are _____, _____, _____, and _____.
- 3) The VCO actually produces an output frequency proportional to an input _____.
- 4) The current switches route one of the currents to the VCO to produce an output _____.
- 5) The frequency is determined by the formula _____.
- 6) Frequency is inversely proportional to the value of _____.
- 7) The resistance between pins 13 and 14 determine the shape of the _____ wave on pin 2.
- 8) No resistor produces a _____ wave.
- 9) A 200Ω resistor produces a _____ wave.
- 10) The six ranges of frequency provided by the range switch are:
_____ to _____. _____ to _____.
_____ to _____. _____ to _____.
_____ to _____. _____ to _____.

Answers: 1) XR-2206; 2) A Voltage Controlled Oscillator, An Analog Multiplier and Sine Shaper, Unity Gain Buffer Amplifier and A Set of Current Switches; 3) Current; 4) Frequency; 5) $1/RC$; 6) $1/RC$; 7) RC; 8) output; 9) sine; 10) 1Hz to 15Hz, 10Hz to 150Hz, 100Hz to 1.5kHz, 1kHz to 15kHz, 10kHz to 150kHz, 100kHz to 1MHz.

ELENCO®

150 Carpenter Avenue

Wheeling, IL 60090

(847) 541-3800

www.elenco.com

e-mail: elenco@elenco.com