

# BURGLAR ALARM KIT

MODEL K-23

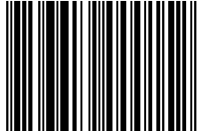

7 56619 00015 2

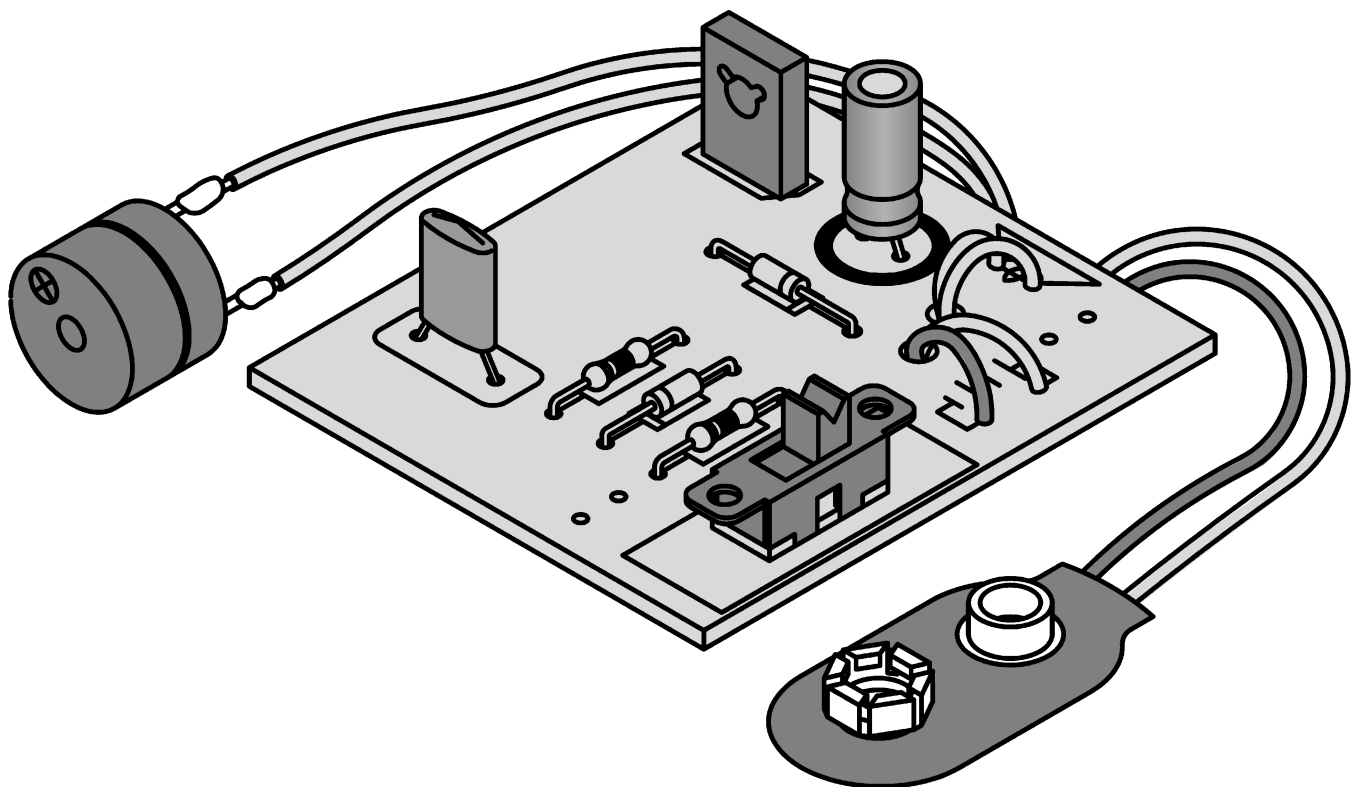

Assembly and Instruction Manual

## ELENCO®

# PARTS LIST

If you are a student, and any parts are missing or damaged, please see instructor or bookstore.

If you purchased this kit from a distributor, catalog, etc., please contact ELENCO® (address/phone/e-mail is at the back of this manual) for additional assistance, if needed. **DO NOT** contact your place of purchase as they will not be able to help you.

## RESISTORS

Qty.	Symbol	Value	Color Code	Part #
□ 2	R1, R2	39kΩ 5% 1/4W	orange-white-orange-gold	153900

## CAPACITORS

Qty.	Symbol	Value	Description	Part #
□ 1	C2	0.1μF (104)	Mylar	251017
□ 1	C1	47μF	Electrolytic	274744

## SEMICONDUCTORS

Qty.	Symbol	Value	Description	Part #
□ 2	D1, D2	1N4001	Diode	314001
□ 1	SCR1	C106B1 or T106B1	SCR	319106

## MISCELLANEOUS

Qty.	Symbol	Description	Part #
□ 1		PC Board	518023
□ 1	S1	Switch	541102
□ 1	B1	Battery Snap	590098
□ 1	A1	Buzzer	595203
□ 1		4" Black Wire	814120
□ 5		4" Blue Wire	814620

## PARTS IDENTIFICATION

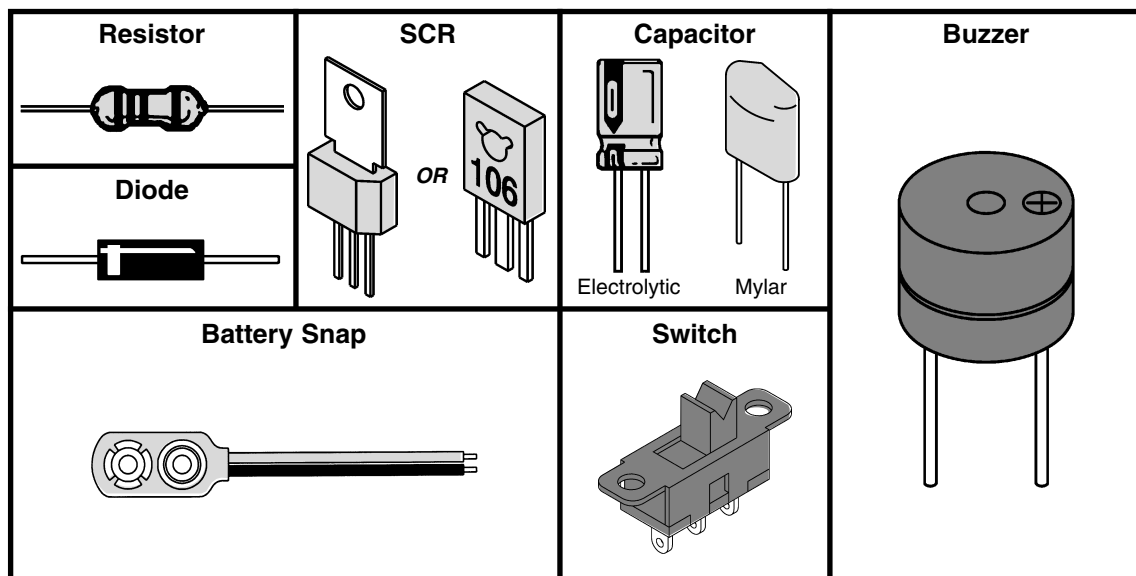

## IDENTIFYING RESISTOR VALUES

Use the following information as a guide in properly identifying the value of resistors.



BAND 1 1st Digit		BAND 2 2nd Digit		Multiplier		Resistance Tolerance	
Color	Digit	Color	Digit	Color	Multiplier	Color	Tolerance
Black	0	Black	0	Black	1	Silver	+10%
Brown	1	Brown	1	Brown	10	Gold	+5%
Red	2	Red	2	Red	100	Brown	+1%
Orange	3	Orange	3	Orange	1,000	Red	+2%
Yellow	4	Yellow	4	Yellow	10,000	Orange	+3%
Green	5	Green	5	Green	100,000	Green	+5%
Blue	6	Blue	6	Blue	1,000,000	Blue	+25%
Violet	7	Violet	7	Silver	0.01	Violet	+1%
Gray	8	Gray	8	Gold	0.1		
White	9	White	9				

## IDENTIFYING CAPACITOR VALUES

Capacitors will be identified by their capacitance value in pF (picofarads), nF (nanofarads), or  $\mu\text{F}$  (microfarads). Most capacitors will have their actual value printed on them. Some capacitors may have their value printed in the following manner.

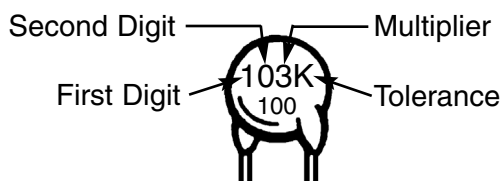

Multiplier	For the No.	0	1	2	3	4	5	8	9
		Multiply By	1	10	100	1k	10k	100k	.01

The above value is  $10 \times 1,000 = 10,000\text{pF}$  or  $.01\mu\text{F}$   
 The letter K indicates a tolerance of  $\pm 10\%$   
 The letter J indicates a tolerance of  $\pm 5\%$

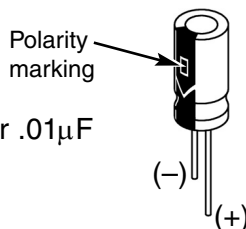

Note: The letter "R" may be used at times to signify a decimal point; as in 3R3 = 3.3

Electrolytic capacitors have a positive and a negative electrode. The negative lead is indicated on the packaging by a stripe with minus signs and possibly arrowheads. Also, the negative lead of a radial electrolytic is shorter than the positive one.

## INTRODUCTION

The Elenco® Burglar Alarm is designed to set off an alarm whenever the circuit is activated. There are two ways of activating the alarm; by opening a contact switch and/or by shorting a contact switch. Once the alarm is ON, returning the switch back to its original position will not turn off the alarm. A third

switch controls the turn-off of the alarm. There is no limit to the number of the switches that can be placed to protect your property. You may use one for each window and door in your house. There also is a feature that allows use of the alarm to protect your automobile and auto accessories.

## POWER SUPPLY

The Elenco® Burglar Alarm is designed to operate from 9-15VDC. The silicon controlled rectifier is the heart of the Burglar Alarm. This device is an electronic switch that allows current to flow only in one direction. Figure 1 shows a simple circuit of an SCR. When a positive voltage is applied to the anode and a negative voltage to the cathode, no current will flow.

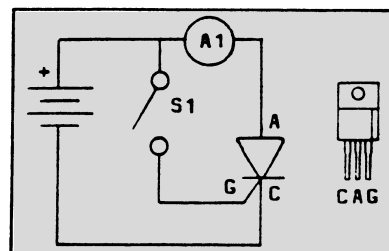

Figure 1

When we place a voltage to the gate, a current will flow between the anode and cathode turning ON the alarm buzzer. If we remove the voltage on the gate, the current will continue to flow in the SCR.

Thus, if a burglar opens the door, the alarm will go off. Closing that door will not turn off the alarm, it will continue to sound. The only way to turn it off is to remove the power to the SCR.

## ACTIVATING SWITCHES

There are two types of activating switches, the normally open (N.O.) contacts and normally closed (N.C.) contacts. Figure 2A shows the N.O. circuit. Remember that the SCR needs gate voltage to fire. When the N.O. switch is closed, the SCR will conduct current and continue to do so even if the N.O. switch is opened.

Figure 2B shows the circuit for a N.C. switch. Here, while the switch is closed, no voltage will be seen at the gate of the SCR. Once the switch is open, the SCR will conduct and continue to do so until the voltage is removed from the anode of the SCR. This important turn on/no turn off feature prevents the intruder from turning off the alarm. When we combine the N.O. and the N.C. circuits, a problem occurs. The N.C. switch will short out the N.O. switch voltage. To prevent this, we add a diode to isolate the two circuits. Figure 3 shows this circuit. The diode D2 prevents the voltage from being shorted out through the N.C. switch. Voltage from R1 will pass through the diode and into the gate of the SCR when SW N.C. is open.

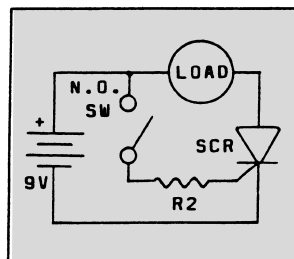

Figure 2A

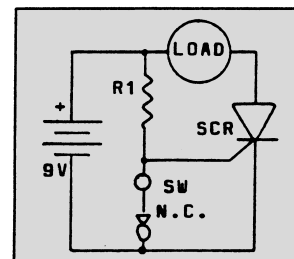

Figure 2B

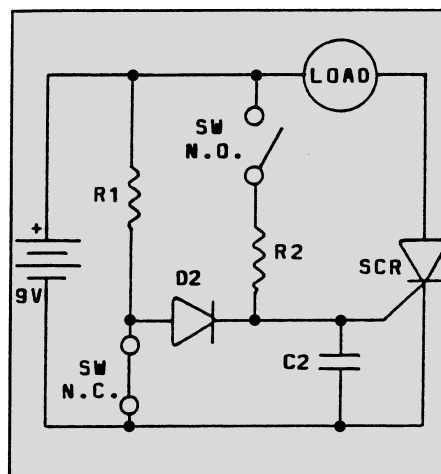

Figure 3

## ELIMINATING FALSE ALARMS

When this alarm is used in an automobile, any jarring of the contact switches may set off the alarm. To prevent this, a capacitor (C2) is added to the circuit. Figure 3 shows the location of C2. When the N.C. or N.O. switch is first activated, the current through R1 or R2 first goes to charge the capacitor. After the capacitor is charged, then the voltage will

build up enough to trigger the SCR. The time may seem very fast, but in electronics, it is a long time when you consider circuits react in microseconds (.000001 sec.). Thus, by adding capacitor C2, any noise spike shorter than one millisecond will not fire the alarm.

## KEEPING THE ALARM ON

The alarm device used in this circuit is a buzzer. This device operates by vibrating back and forth, interrupting the current. Remember that the SCR will turn off if the gate has no voltage and the anode also loses its voltage to the cathode, a capacitor (C1) is added across the buzzer, as shown in Figure 4.

This capacitor will keep the current flowing in the SCR whenever the buzzer opens up.

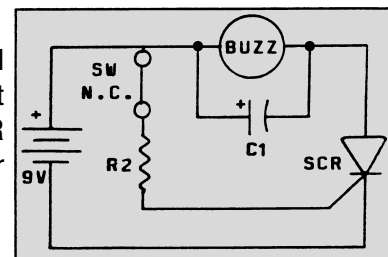

Figure 4

## EXTERNAL ALARM

The Burglar Alarm can be used to control a relay, such as the relay in your auto horn system. To do so, simply replace the buzzer with the relay. Whenever the alarm is fired, the relay will close, setting off the

alarm. A diode (D1) is placed across the relay to remove the excessive voltage generated by the relay coil from damaging the SCR.

# CONSTRUCTION

## Introduction

The most important factor in assembling your K-23 Burglar Alarm Kit is good soldering techniques. Using the proper soldering iron is of prime importance. A small pencil type soldering iron of 25 - 40 watts is recommended. **The tip of the iron must be kept clean at all times and well-tinned.**

## Solder

For many years leaded solder was the most common type of solder used by the electronics industry, but it is now being replaced by lead-free solder for health reasons. This kit contains lead-free solder, which contains 99.3% tin, 0.7% copper, and has a rosin-flux core.

Lead-free solder is different from lead solder: It has a higher melting point than lead solder, so you need higher temperature for the solder to flow properly. Recommended tip temperature is approximately 700°F; higher temperatures improve solder flow but accelerate tip decay. An increase in soldering time may be required to achieve good results. Soldering iron tips wear out faster since lead-free solders are more corrosive and the higher soldering temperatures accelerate corrosion, so proper tip care is important. The solder joint finish will look slightly duller with lead-free solders.

Use these procedures to increase the life of your soldering iron tip when using lead-free solder:

- Keep the iron tinned at all times.
- Use the correct tip size for best heat transfer. The conical tip is the most commonly used.

- Turn off iron when not in use or reduce temperature setting when using a soldering station.
- Tips should be cleaned frequently to remove oxidation before it becomes impossible to remove. Use Dry Tip Cleaner (Elenco® #SH-1025) or Tip Cleaner (Elenco® #TTC1). If you use a sponge to clean your tip, then use distilled water (tap water has impurities that accelerate corrosion).

## Safety Procedures

- **Always wear safety glasses or safety goggles to protect your eyes when working with tools or soldering iron, and during all phases of testing.** 
- Be sure there is **adequate ventilation** when soldering.
- Locate soldering iron in an area where you do not have to go around it or reach over it. Keep it in a safe area away from the reach of children.
- **Do not hold solder in your mouth.** Solder is a toxic substance. Wash hands thoroughly after handling solder.

## Assemble Components

In all of the following assembly steps, the components must be installed on the top side of the PC board unless otherwise indicated. The top legend shows where each component goes. The leads pass through the corresponding holes in the board and are soldered on the foil side.

**Use only rosin core solder.**

**DO NOT USE ACID CORE SOLDER!**

## What Good Soldering Looks Like

A good solder connection should be bright, shiny, smooth, and uniformly flowed over all surfaces.

1. Solder all components from the copper foil side only. Push the soldering iron tip against both the lead and the circuit board foil.

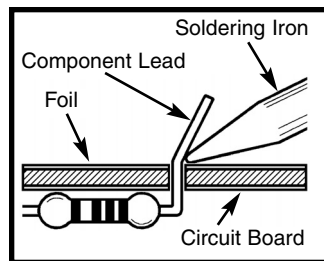

2. Apply a small amount of solder to the iron tip. This allows the heat to leave the iron and onto the foil. Immediately apply solder to the opposite side of the connection, away from the iron. Allow the heated component and the circuit foil to melt the solder.

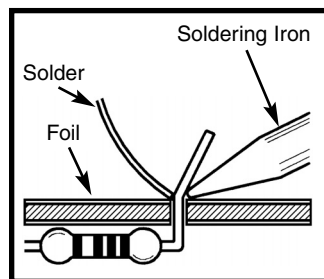

3. Allow the solder to flow around the connection. Then, remove the solder and the iron and let the connection cool. The solder should have flowed smoothly and not lump around the wire lead.

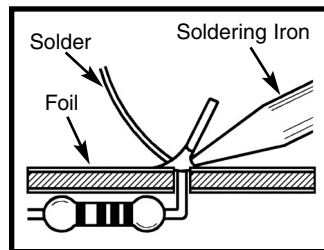

4. Here is what a good solder connection looks like.

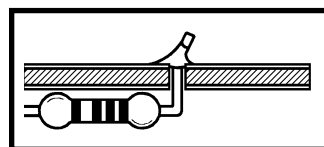

## Types of Poor Soldering Connections

1. **Insufficient heat** - the solder will not flow onto the lead as shown.

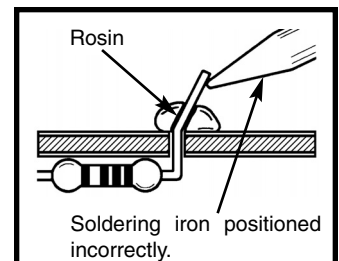

2. **Insufficient solder** - let the solder flow over the connection until it is covered. Use just enough solder to cover the connection.

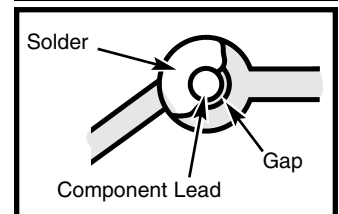

3. **Excessive solder** - could make connections that you did not intend to between adjacent foil areas or terminals.

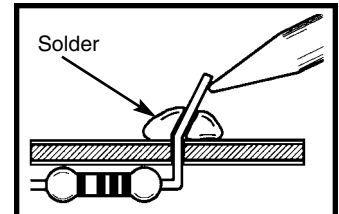

4. **Solder bridges** - occur when solder runs between circuit paths and creates a short circuit. This is usually caused by using too much solder. To correct this, simply drag your soldering iron across the solder bridge as shown.

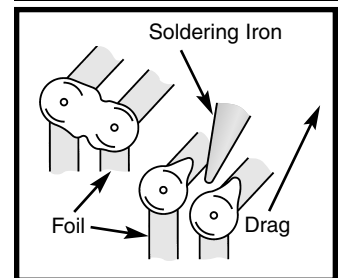

# ASSEMBLE COMPONENTS TO THE PC BOARD

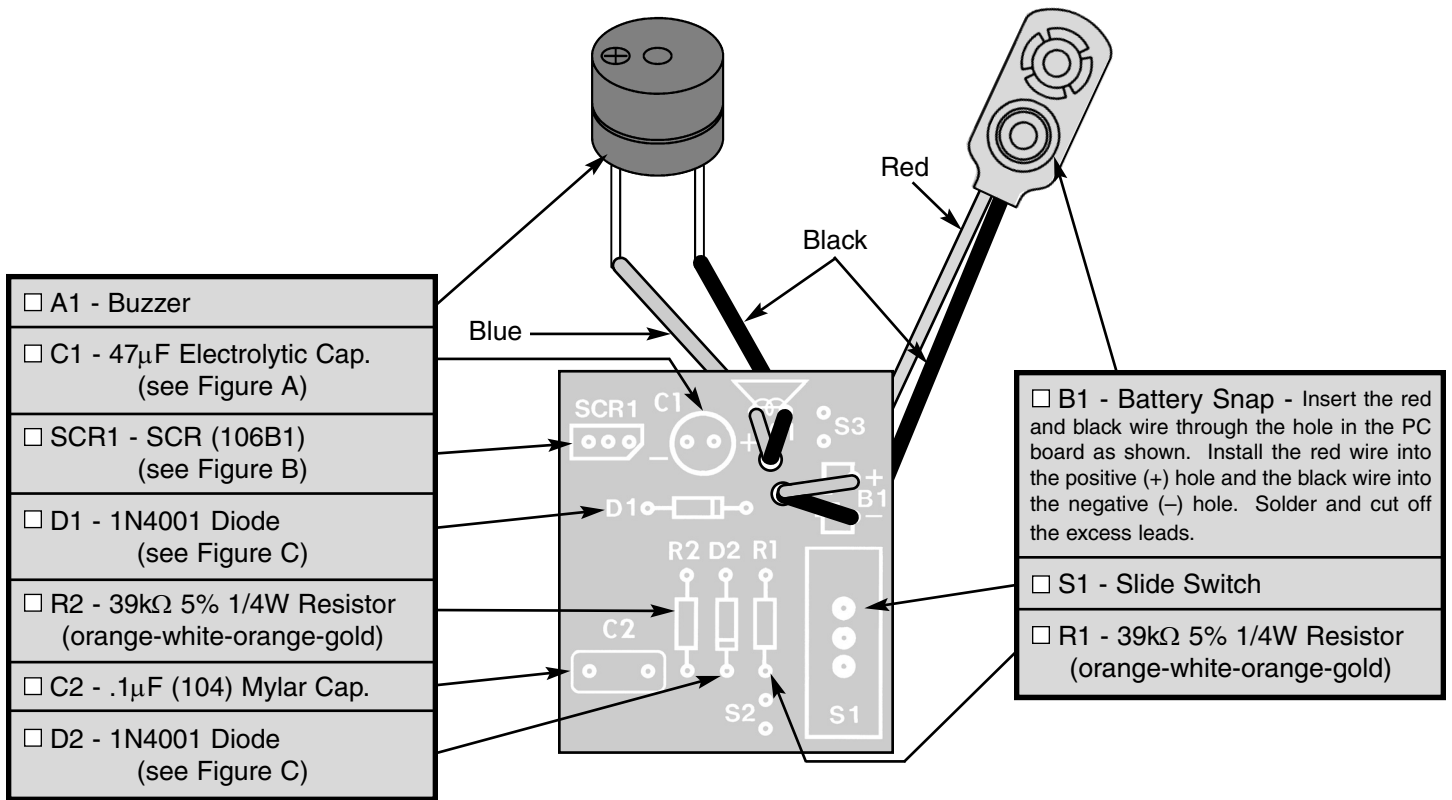

**Figure A**

Electrolytic capacitors have polarity. Mount the capacitor with the positive lead in the hole marked (+) on the PC board.

**Warning:** If the capacitor is connected with incorrect polarity it may heat up and either leak or cause the capacitor to explode.

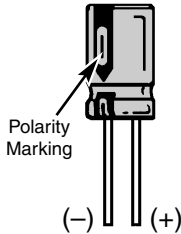

**Figure B**

Mount the SCR in the same direction as marked on the PC board. Be sure that the metal backing is in the direction shown.

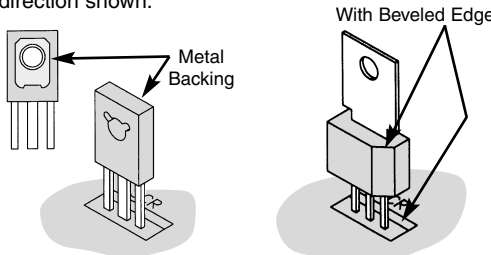

**Figure C**

Diodes have polarity. Mount them with the band in the correct direction, as shown on the PC board.

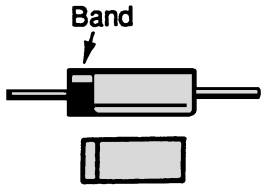

---

## TESTING INSTRUCTIONS

1. Connect a 9V type battery to the battery snap (battery not included).
2. Switch S1, power switch, on (up position).
3. Short two wires connected to S3 together, buzzer should activate. Disconnect the wires from S3, the buzzer should still be on. Turn off S1 (down position) to reset the alarm.
4. Turn S1 on (up position). Disconnect the wires from S2 and the buzzer should activate. Reconnect the wires to S2, the buzzer should still be on. Turn off S1 to reset the alarm.
5. If your K-23 does not operate properly, follow the troubleshooting procedure below.

---

## TROUBLESHOOTING

Contact ELENCO® if you have any problems. **DO NOT** contact your place of purchase as they will not be able to help you.

1. One of the most frequently occurring problems is poor solder connections.
  - a) Tug slightly on all parts to make sure that they are indeed soldered.
  - b) All solder connections should be shiny. Resolder any that are not.
  - c) Solder should flow into a smooth puddle rather than a round ball. Resolder any connection that has formed into a ball.
  - d) Have any solder bridges formed? A solder bridge may occur if you accidentally touch an adjacent foil by using too much solder or by dragging the soldering iron across adjacent foils. Break the bridge with your soldering iron.
2. Be sure that all components have been mounted in their correct places.
  - a) Make sure that C1, the electrolytic capacitor, is mounted correctly.
  - b) Make sure that diodes D1 and D2 are mounted correctly with the band in the same direction as shown on the top legend.
  - c) Make sure that the battery snap B1 is installed correctly. The red wire should be in the positive (+) hole and the black wire in the negative (-) hole.
  - d) Make sure that the buzzer is wired correctly (blue wire to (+) lead).
  - e) Make sure that the SCR is in correctly.
  - f) Use a fresh 9 volt battery.

---

## QUIZ

1. The Burglar Alarm is powered by a \_\_\_\_\_ volt battery.
2. The main component of the Burglar Alarm is the \_\_\_\_\_.
3. The two types of activating switches are the normally \_\_\_\_\_ contact and the normally \_\_\_\_\_ contacts.
4. The SCR will only conduct current when the \_\_\_\_\_ is at a positive voltage.
5. An SCR will continue to conduct current from Anode to Cathode even if the gate is \_\_\_\_\_.
6. Once the SCR is fired, one way to turn it off is to \_\_\_\_\_ the anode voltage.
7. False alarms are eliminated by the use of a \_\_\_\_\_.
8. The alarm device used in this circuit is an electronic \_\_\_\_\_.
9. Capacitor \_\_\_\_\_ is added across the buzzer to keep the current flowing in the SCR.
10. Diode D1 is added across the relay to remove excessive \_\_\_\_\_ to the SCR.

# AUTO ALARM

You will not mount parts A1, B1 or S1. When someone opens a door or tries to remove the radio, the alarm is activated and the car horn will sound (see schematic diagram below).

Connect to your car as follows. See diagram below.

**Connect P4** to the wire running from the door switch to the dome light.

**Connect P1** to the wire running from the horn relay to the horn switch, which is located in the steering wheel.

**Connect P2** to an alarm turn-off switch (use S1, be sure to use the middle lug for one of the connections). Connect the other end of the switch to the car battery via fuse box.

**Connect P9** to the metal casing on the radio which is grounded. When the lead is separated from the ground, the alarm will be activated and the horn will sound. If you do not want to protect a sound system, connect the lead permanently to a ground.

**Connect P10** to the car ground.

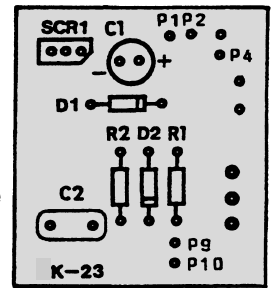

## OPERATING PROCEDURES (Auto Alarm)

Attach a fresh 9 volt battery to the battery snap. Connect the leads from S2 to any normally closed switch. If you do not wish to use this switch, simply connect these leads together. Connect the leads from S3 to any normally open switch. When either

S2 is opened, or S3 is closed, the alarm will turn on and stay on even if switches S2 and S3 are switched back. To reset the alarm, turn switch S1 off and then back on again. A key lock switch can be substituted for S1.

## SCHEMATIC DIAGRAMS FOR AUTO ALARM

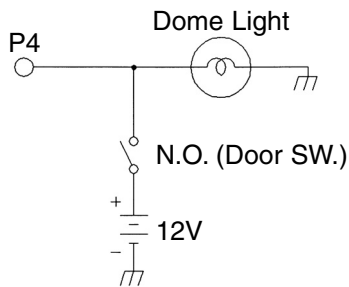

Auto Door Alarm Connection

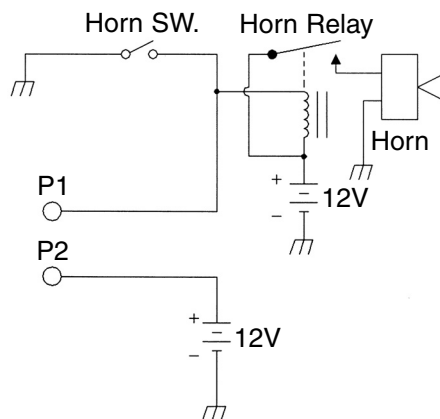

Car Horn Connection

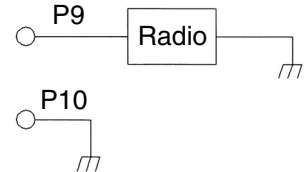

Radio Alarm Connection

## SCHEMATIC DIAGRAM

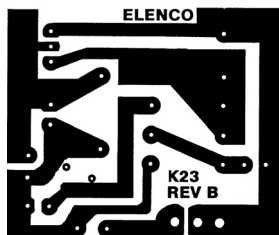
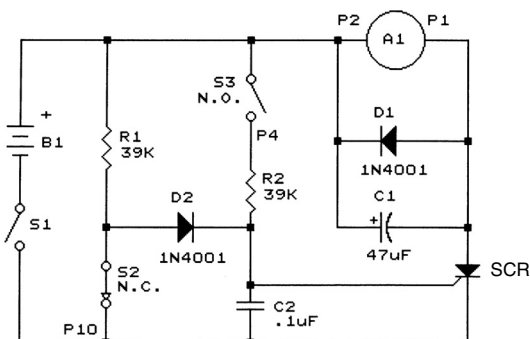

Foil Side of PC Board

## ELENCO®

150 Carpenter Avenue  
Wheeling, IL 60090  
(847) 541-3800

Website: [www.elenco.com](http://www.elenco.com)  
e-mail: [elenco@elenco.com](mailto:elenco@elenco.com)

Answers: 1. 9; 2. Silicon Controlled Rectifier (SCR); 3. open, closed; 4. gate; 5. negative; 6. remove; 7. capacitor; 8. buzzer; 9. C1; 10. voltage