

LOGIC PROBE KIT

MODEL LP-525K

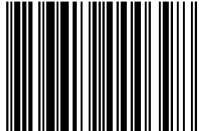

7 56619 00039 8



Assembly and Instruction Manual

ELENCO®

PARTS LIST

If you are a student, and any parts are missing or damaged, please see instructor or bookstore.

If you purchased this LP-525K Logic Probe Kit from a distributor, catalog, etc., please contact ELENCO® (address/phone/e-mail is at the back of this manual) for additional assistance, if needed. **DO NOT** contact your place of purchase as they will not be able to help you.

RESISTORS

| Qty. | Symbol | Description | Color Code | Part # |
|----------------------------|-----------------------|---------------|--------------------------|--------|
| <input type="checkbox"/> 3 | R21, R23, R24 | 200Ω 5% 1/4W | red-black-brown-gold | 132000 |
| <input type="checkbox"/> 1 | R16 | 2kΩ 5% 1/4W | red-black-red-gold | 142000 |
| <input type="checkbox"/> 1 | R4 | 4.7kΩ 5% 1/4W | yellow-violet-red-gold | 144700 |
| <input type="checkbox"/> 1 | R14 | 5.1kΩ 5% 1/4W | green-brown-red-gold | 145100 |
| <input type="checkbox"/> 1 | R11 | 15kΩ 5% 1/4W | brown-green-orange-gold | 151500 |
| <input type="checkbox"/> 1 | R13 | 18kΩ 5% 1/4W | brown-gray-orange-gold | 151800 |
| <input type="checkbox"/> 2 | R10, R15 | 20kΩ 5% 1/4W | red-black-orange-gold | 152000 |
| <input type="checkbox"/> 2 | R12, R22 | 30kΩ 5% 1/4W | orange-black-orange-gold | 153000 |
| <input type="checkbox"/> 7 | R1, R5 - R8, R19, R20 | 100kΩ 5% 1/4W | brown-black-yellow-gold | 161000 |
| <input type="checkbox"/> 1 | R17 | 120kΩ 5% 1/4W | brown-red-yellow-gold | 161200 |
| <input type="checkbox"/> 1 | R18 | 150kΩ 5% 1/4W | brown-green-yellow-gold | 161500 |
| <input type="checkbox"/> 3 | R2, R3, R9 | 4.7MΩ 5% 1/4W | yellow-violet-green-gold | 174700 |

CAPACITORS

| Qty. | Symbol | Description | Part # | Qty. | Symbol | Description | Part # |
|----------------------------|--------|----------------------|--------|----------------------------|--------|----------------------|--------|
| <input type="checkbox"/> 1 | C2 | 100pF (101) Discap | 221017 | <input type="checkbox"/> 1 | C4 | 0.005μF (502) Discap | 235018 |
| <input type="checkbox"/> 1 | C3 | 200pF (201) Discap | 222010 | <input type="checkbox"/> 1 | C5 | 0.047μF (473) Discap | 244780 |
| <input type="checkbox"/> 2 | C1, C6 | 0.001μF (102) Discap | 231036 | <input type="checkbox"/> 1 | C7 | 0.1μF (104) Discap | 251010 |





SEMICONDUCTORS

| Qty. | Symbol | Description | Part # | Qty. | Symbol | Description | Part # |
|----------------------------|---------|-------------------|--------|----------------------------|----------|-------------------|--------|
| <input type="checkbox"/> 1 | D6 | 1N4002 Diode | 314002 | <input type="checkbox"/> 3 | Q1, 3, 5 | 2N3906 Transistor | 323906 |
| <input type="checkbox"/> 5 | D1 - D5 | 1N4148 Diode | 314148 | <input type="checkbox"/> 1 | U1 | LM2901 IC | 332901 |
| <input type="checkbox"/> 2 | Q2, Q4 | 2N3904 Transistor | 323904 | <input type="checkbox"/> 3 | L1 - L3 | LED | 350001 |

MISCELLANEOUS

| Qty. | Description | Part # | Qty. | Description | Part # |
|----------------------------|----------------------|--------|-----------------------------|-----------------------|--------|
| <input type="checkbox"/> 1 | PC board | 517014 | <input type="checkbox"/> 1 | Label front | 724002 |
| <input type="checkbox"/> 2 | Switch SPDT | 541024 | <input type="checkbox"/> 1 | Label back | 724003 |
| <input type="checkbox"/> 1 | Probe tip | 616001 | <input type="checkbox"/> 1 | Wire 1.5" | 814220 |
| <input type="checkbox"/> 1 | Case | 623005 | <input type="checkbox"/> 3' | Wire 2 cond. | 870500 |
| <input type="checkbox"/> 2 | Screw #4 x 5/8" | 643450 | <input type="checkbox"/> 3" | Tubing #20 | 890020 |
| <input type="checkbox"/> 1 | IC socket 14-pin | 664014 | <input type="checkbox"/> 1" | Shrink tubing (red) | 890312 |
| <input type="checkbox"/> 1 | Alligator clip black | 680001 | <input type="checkbox"/> 1 | Solder tube lead-free | 9LF99 |
| <input type="checkbox"/> 1 | Alligator clip red | 680002 | | | |

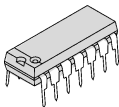
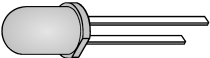
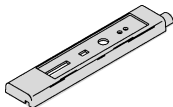
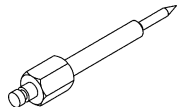
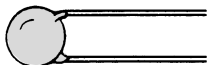
PARTS IDENTIFICATION

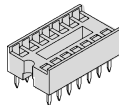
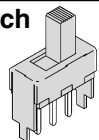
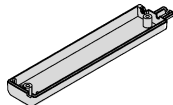
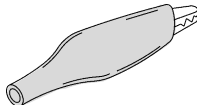
| | | | | | |
|---|--|--|--|---|--|
| Resistor  | Diode  | Integrated Circuit  | LED  | Case Top  | Probe Tip  |
| Capacitor  | Transistor  | IC Socket  | Switch  | Case Bottom  | Alligator Clip  |

IDENTIFYING RESISTOR VALUES

Use the following information as a guide in properly identifying the value of resistors.

| BAND 1 1st Digit | | BAND 2 2nd Digit | | Multiplier | | Resistance Tolerance | |
|---------------------|-------|---------------------|-------|------------|------------|-------------------------|-------------|
| Color | Digit | Color | Digit | Color | Multiplier | Color | Tolerance |
| Black | 0 | Black | 0 | Black | 1 | Silver | $\pm 10\%$ |
| Brown | 1 | Brown | 1 | Brown | 10 | Gold | $\pm 5\%$ |
| Red | 2 | Red | 2 | Red | 100 | Brown | $\pm 1\%$ |
| Orange | 3 | Orange | 3 | Orange | 1,000 | Red | $\pm 2\%$ |
| Yellow | 4 | Yellow | 4 | Yellow | 10,000 | Orange | $\pm 3\%$ |
| Green | 5 | Green | 5 | Green | 100,000 | Green | $\pm .5\%$ |
| Blue | 6 | Blue | 6 | Blue | 1,000,000 | Blue | $\pm .25\%$ |
| Violet | 7 | Violet | 7 | Silver | 0.01 | Violet | $\pm .1\%$ |
| Gray | 8 | Gray | 8 | Gold | 0.1 | | |
| White | 9 | White | 9 | | | | |

BANDS

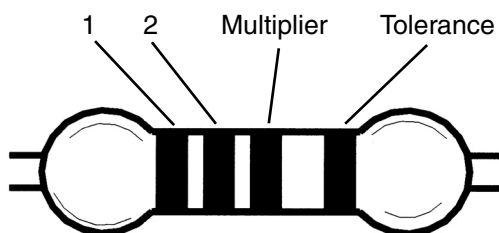

IDENTIFYING CAPACITOR VALUES

Capacitors will be identified by their capacitance value in pF (picofarads), nF (nanofarads), or μF (microfarads). Most capacitors will have their actual value printed on them. Some capacitors may have their value printed in the following manner. The maximum operating voltage may also be printed on the capacitor.

| Multiplier | For the No. | 0 | 1 | 2 | 3 | 4 | 5 | 8 | 9 |
|------------|-------------|---|---|----|-----|----|-----|------|-----|
| | Multiply By | | 1 | 10 | 100 | 1k | 10k | 100k | .01 |

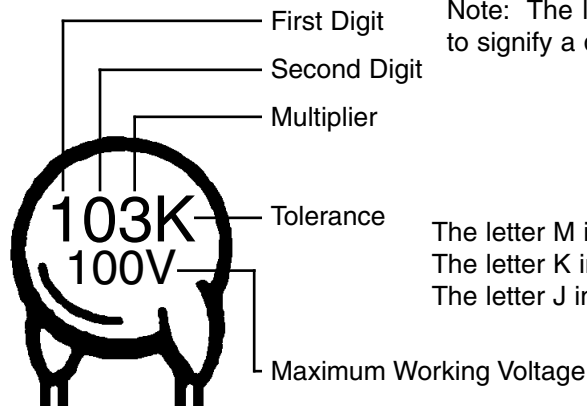

Note: The letter "R" may be used at times to signify a decimal point; as in 3R3 = 3.3

The letter M indicates a tolerance of $\pm 20\%$
 The letter K indicates a tolerance of $\pm 10\%$
 The letter J indicates a tolerance of $\pm 5\%$

The value is $10 \times 1,000 = 10,000\text{pF}$ or $.01\mu\text{F}$ 100V

METRIC UNITS AND CONVERSIONS

| Abbreviation | Means | Multiply Unit By | Or |
|--------------|-------|------------------|------------|
| p | Pico | .000000000001 | 10^{-12} |
| n | nano | .000000001 | 10^{-9} |
| μ | micro | .000001 | 10^{-6} |
| m | milli | .001 | 10^{-3} |
| - | unit | 1 | 10^0 |
| k | kilo | 1,000 | 10^3 |
| M | mega | 1,000,000 | 10^6 |

- 1,000 pico units = 1 nano unit
- 1,000 nano units = 1 micro unit
- 1,000 micro units = 1 milli unit
- 1,000 milli units = 1 unit
- 1,000 units = 1 kilo unit
- 1,000 kilo units = 1 mega unit

CIRCUIT DESCRIPTION

The Elenco® Model LP-525K Logic Probe kit is a convenient and precise instrument for use in the measurement of logic circuits. It displays logic levels (high or low), and voltage transients down to 25 nanoseconds. The LED readouts provide instant response to the logic state.

To detect the high and low logic levels, the LP-525 uses two comparators of a Quad Comparator LM2901 Integrated Circuit (see schematic diagram). One comparator drives the HI LED and the other drives the LOW LED. The comparator output goes low, lighting the LED, when the (–) input is more positive than the (+) input. To measure TTL circuits, the TTL-CMOS switch is set to TTL and the red and black alligator clips are connected to +5VDC and ground. The (+) input (pin 5) of the HI comparator is then biased to 2.3VDC by resistor network R9 through R15. Thus, the LED lights when the probe tip is more positive than 2.3VDC. To measure CMOS circuits, the HI comparator changes to 3.5VDC or 70% of the supply voltage.

The (–) input of the LOW comparator is biased to .8VDC for TTL operation and 1.5VDC or 30% of the supply voltage for CMOS operation. The LOW LED thus lights when the probe tip is connected to voltages less than .8 or 1.5VDC.

The pulse LED is controlled by a bipolar edge detector circuit which responds to both positive and negative transients. This circuit is made up of capacitors C2 and C3, transistors Q1 through Q4, and the associated resistors. When the circuit is activated by pulses as short as 25 nanoseconds, a negative pulse is applied to the (+) input (pin 11) of the pulse stretcher comparator. The comparator then turns on and is held by the feedback resistor R8. The ground level on the output (pin 13) causes C5 to discharge through R17. In approximately 1.5 milliseconds, the voltage on the (–) input (pin 10)

becomes more negative than the (+) input and the comparator turns off. The short pulse on the input is thus stretched to 1.5 milliseconds.

The (–) input (pin 8) of the PULSE LED driver is biased to +2.5VDC by resistors R19 and R20. The (+) input is biased to +3VDC by resistors R6 and R18. The 1.5 milliseconds pulse from the pulse stretcher grounds the (+) input through diode D5 turning the comparator on and lighting the PULSE LED. When the PULSE-MEM switch is in MEM, Q5 is also turned on, causing the (–) input of the comparator to go to +5VDC. This keeps the comparator on even after the (+) input returns to +3VDC. When the PULSE-MEM switch is in PULSE, the feedback path to the (–) input is broken and the LED is lit only for the duration of the 1.5 milliseconds pulse.

Thus, each time the input signal changes state, the PULSE LED is activated for 1.5 milliseconds. When observing low frequency signals, the PULSE LED provides an immediate indication of this pulse activity. By observing the HI and LOW LEDs, the polarity of the pulse train can be determined. Low frequencies cause the PULSE LED to blink once for each transition. High frequencies cause the LED to flash at a rate that makes it appear to be on continuously. When the PULSE-MEM switch is in MEM, a single input pulse will cause the PULSE LED to come on and stay on until the switch is returned to the PULSE position.

The input impedance of the LP-525 is 1MΩ. This eliminates any loading effect on the circuit under test.

CAUTION: Do not connect the alligator clips to any AC power source or to a DC power source greater than 35VDC. Failure to comply with this warning may result in damage to this instrument.

SPECIFICATIONS

| | | |
|---------------------------|---------------------------------|-------------|
| Input Impedance | 1MΩ | |
| Input Overload Protection | 50V DC continuous | |
| Thresholds | Logic 1 | Logic 0 |
| TTL | 2.3 ± .25V | 0.80V ± .1V |
| CMOS | 70% Vcc | 30% Vcc |
| Response better than | 25 nanoseconds | |
| Pulse Detector | 1.5 millisecond pulse stretcher | |
| Power Requirements | 5V Vcc @ 30mA | |
| | 15V Vcc @ 40mA | |
| Operating Temperature | –40°C to +85°C | |

CONSTRUCTION

Introduction

The most important factor in assembling your LP-525K Logic Probe Kit is good soldering techniques. Using the proper soldering iron is of prime importance. A small pencil type soldering iron of 25 - 40 watts is recommended. **The tip of the iron must be kept clean at all times and well-tinned.**

Solder

For many years leaded solder was the most common type of solder used by the electronics industry, but it is now being replaced by lead-free solder for health reasons. This kit contains lead-free solder, which contains 99.3% tin, 0.7% copper, and has a rosin-flux core.

Lead-free solder is different from lead solder: It has a higher melting point than lead solder, so you need higher temperature for the solder to flow properly. Recommended tip temperature is approximately 700°F; higher temperatures improve solder flow but accelerate tip decay. An increase in soldering time may be required to achieve good results. Soldering iron tips wear out faster since lead-free solders are more corrosive and the higher soldering temperatures accelerate corrosion, so proper tip care is important. The solder joint finish will look slightly duller with lead-free solders.

Use these procedures to increase the life of your soldering iron tip when using lead-free solder:

- Keep the iron tinned at all times.
- Use the correct tip size for best heat transfer. The conical tip is the most commonly used.

- Turn off iron when not in use or reduce temperature setting when using a soldering station.
- Tips should be cleaned frequently to remove oxidation before it becomes impossible to remove. Use Dry Tip Cleaner (Elenco® #SH-1025) or Tip Cleaner (Elenco® #TTC1). If you use a sponge to clean your tip, then use distilled water (tap water has impurities that accelerate corrosion).

Safety Procedures

- **Always wear safety glasses or safety goggles to protect your eyes when working with tools or soldering iron, and during all phases of testing.** 
- Be sure there is **adequate ventilation** when soldering.
- Locate soldering iron in an area where you do not have to go around it or reach over it. Keep it in a safe area away from the reach of children.
- **Do not hold solder in your mouth.** Solder is a toxic substance. Wash hands thoroughly after handling solder.

Assemble Components

In all of the following assembly steps, the components must be installed on the top side of the PC board unless otherwise indicated. The top legend shows where each component goes. The leads pass through the corresponding holes in the board and are soldered on the foil side.

Use only rosin core solder.

DO NOT USE ACID CORE SOLDER!

What Good Soldering Looks Like

A good solder connection should be bright, shiny, smooth, and uniformly flowed over all surfaces.

1. Solder all components from the copper foil side only. Push the soldering iron tip against both the lead and the circuit board foil.

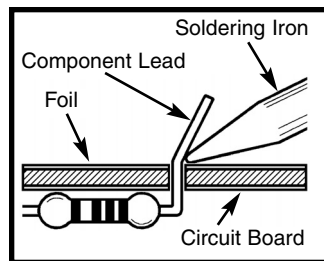

2. Apply a small amount of solder to the iron tip. This allows the heat to leave the iron and onto the foil. Immediately apply solder to the opposite side of the connection, away from the iron. Allow the heated component and the circuit foil to melt the solder.

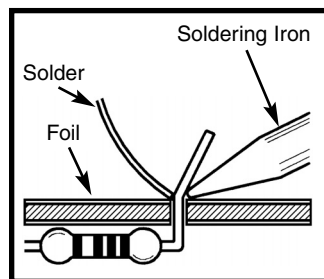

3. Allow the solder to flow around the connection. Then, remove the solder and the iron and let the connection cool. The solder should have flowed smoothly and not lump around the wire lead.

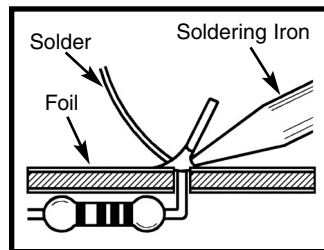

4. Here is what a good solder connection looks like.

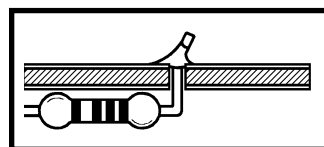

Types of Poor Soldering Connections

1. **Insufficient heat** - the solder will not flow onto the lead as shown.

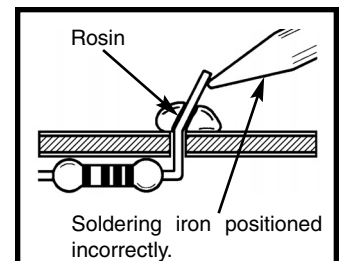

2. **Insufficient solder** - let the solder flow over the connection until it is covered. Use just enough solder to cover the connection.

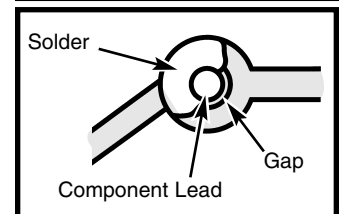

3. **Excessive solder** - could make connections that you did not intend to between adjacent foil areas or terminals.

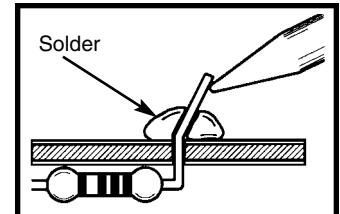

4. **Solder bridges** - occur when solder runs between circuit paths and creates a short circuit. This is usually caused by using too much solder. To correct this, simply drag your soldering iron across the solder bridge as shown.

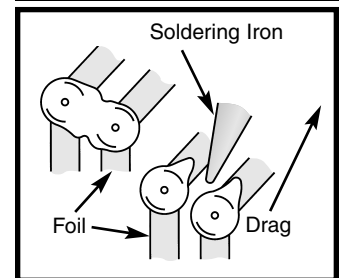

ASSEMBLE COMPONENTS TO THE PC BOARD

Refer to the top legend on the PC board, install and solder the following resistors.

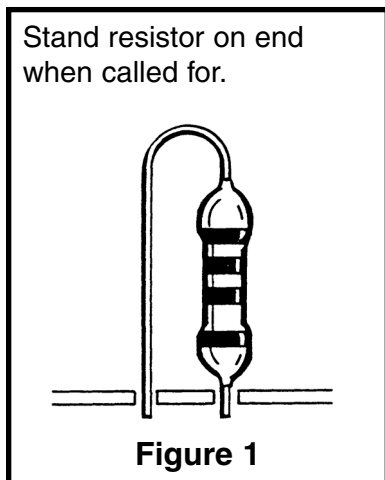

- R13 - 18kΩ Resistor (brown-gray-orange-gold)
- R9 - 4.7MΩ Resistor (yellow-violet-green-gold)
- R10 - 20kΩ Resistor (red-black-orange-gold)
- R12 - 30kΩ Resistor (orange-black-orange-gold)
- R20 - 100kΩ Resistor (brown-black-yellow-gold) (see Figure 1)
- R17 - 120kΩ Resistor (brown-red-yellow-gold) (see Figure 1)
- R19 - 100kΩ Resistor (brown-black-yellow-gold)
- R2 - 4.7MΩ Resistor (yellow-violet-green-gold)
- R15 - 20kΩ Resistor (red-black-orange-gold)
- R16 - 2kΩ Resistor (red-black-red-gold)

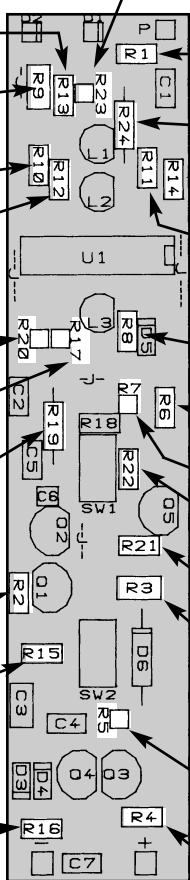

- R23 - 200Ω Resistor (red-black-brown-gold) (see Figure 1)
- R1 - 100kΩ Resistor (brown-black-yellow-gold)
- R24 - 200Ω Resistor (red-black-brown-gold)
- R14 - 5.1kΩ Resistor (green-brown-red-gold)
- R11 - 15kΩ Resistor (brown-green-orange-gold)
- R8 - 100kΩ Resistor (brown-black-yellow-gold)
- R6 - 100kΩ Resistor (brown-black-yellow-gold)
- R7 - 100kΩ Resistor (brown-black-yellow-gold) (see Figure 1)
- R22 - 30kΩ Resistor (orange-black-orange-gold)
- R21 - 200Ω Resistor (red-black-brown-gold)
- R3 - 4.7MΩ Resistor (yellow-violet-green-gold)
- R5 - 100kΩ Resistor (brown-black-yellow-gold) (see Figure 1)
- R4 - 4.7kΩ Resistor (yellow-violet-red-gold)

Save 5 discarded leads for jumper wires.

ASSEMBLE COMPONENTS TO THE PC BOARD

Refer to the top legend on the PC board, install and solder the following diodes, capacitors and jumper wires.

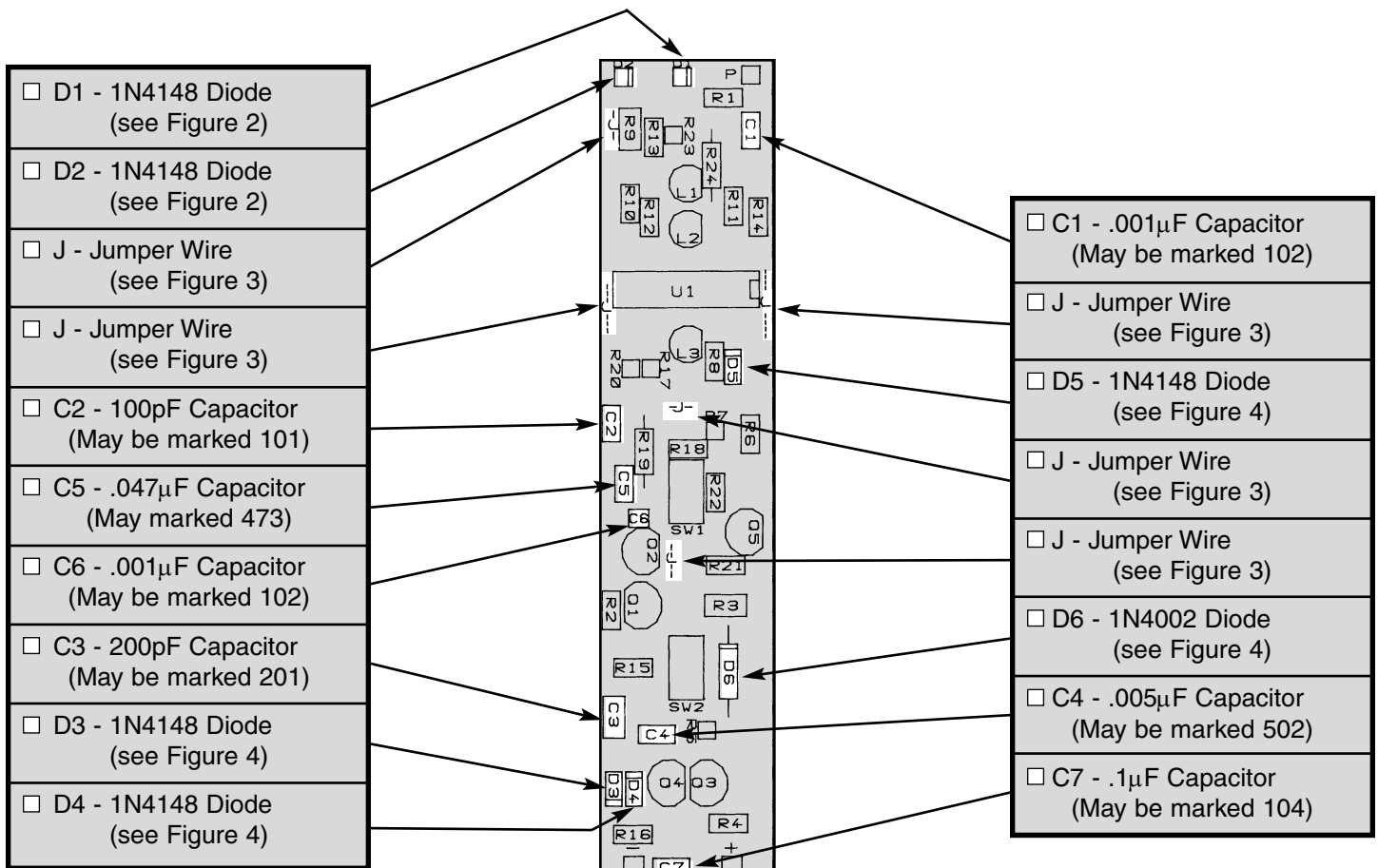
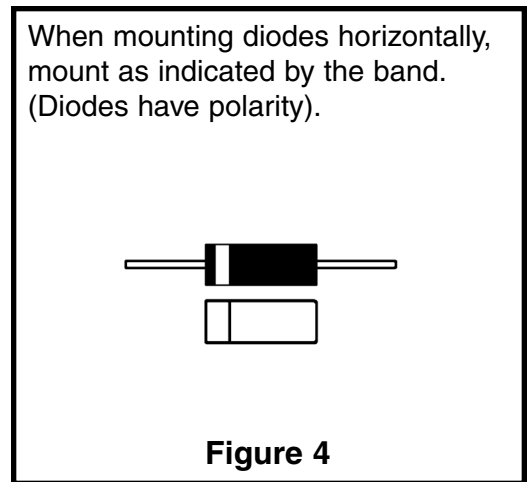
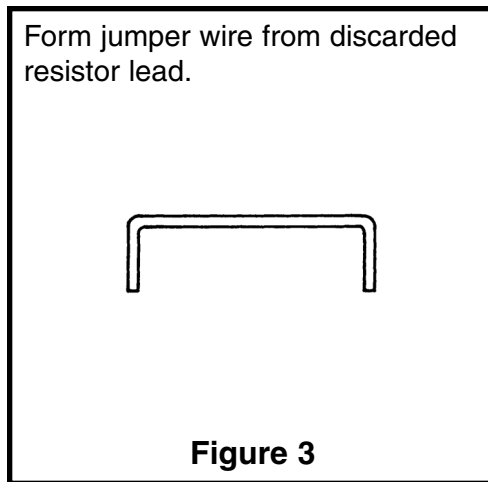
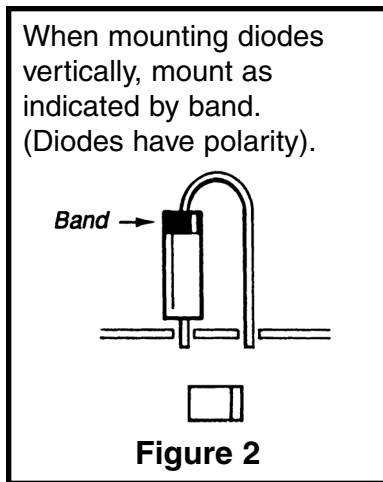

ASSEMBLE COMPONENTS TO THE PC BOARD

Refer to the top legend on the PC board, install and solder the following components.

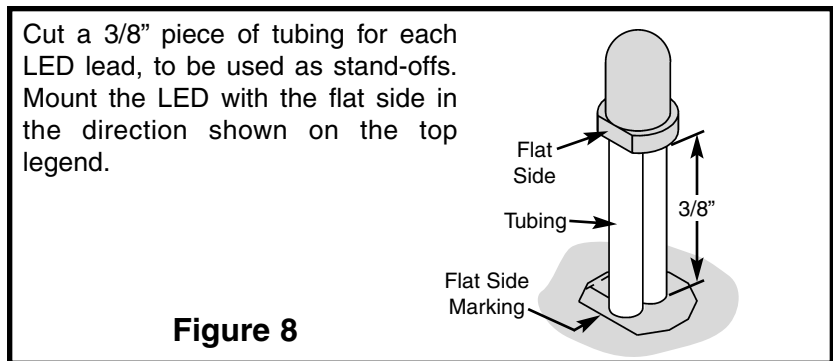
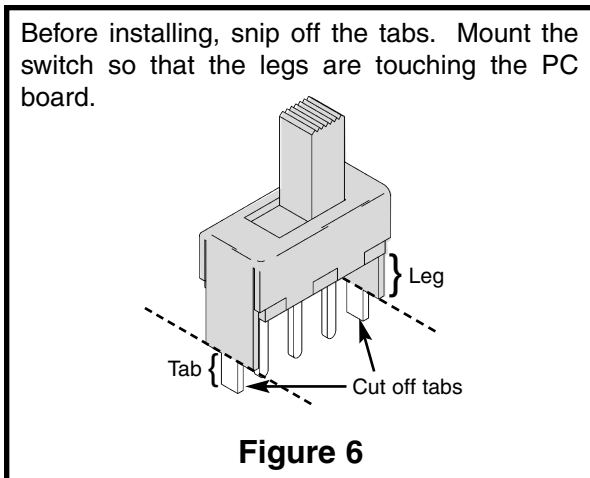
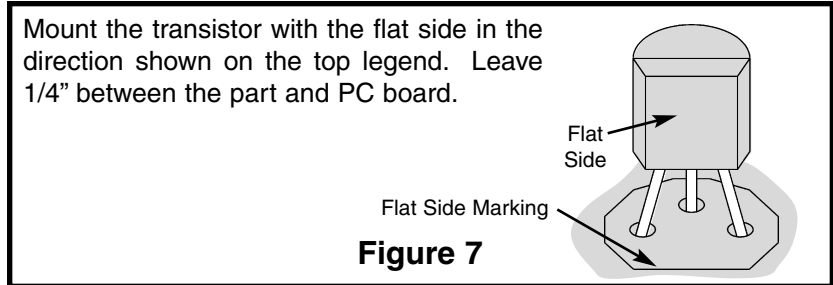
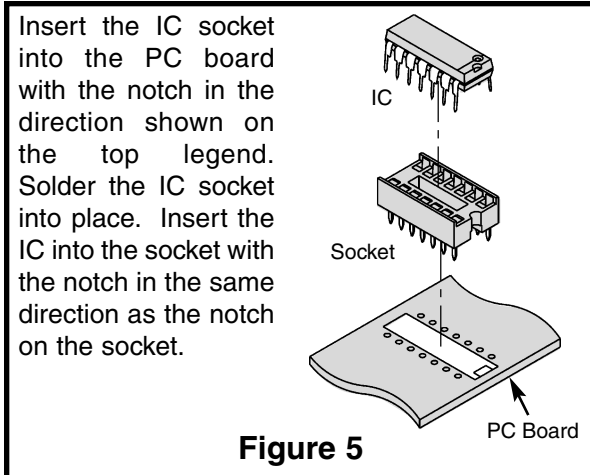

- U1 - 14-pin IC Socket
- U1 - LM2901 IC (see Figure 5)
- SW1 - Switch (see Figure 6)
- Q2 - 2N3904 Transistor (see Figure 7)
- Q1 - 2N3906 Transistor (see Figure 7)
- SW2 - Switch (see Figure 6)
- Q4 - 2N3904 Transistor (see Figure 7)

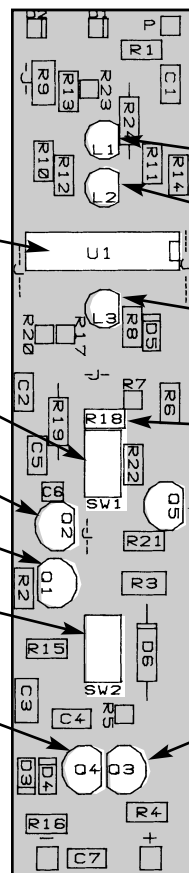

- L1 - LED (see Figure 8)
- L2 - LED (see Figure 8)
- L3 - LED (see Figure 8)
- R18 - 150kΩ Resistor (brown-green-yellow-gold) Install SW1 first.
- Q5 - 2N3906 Transistor (see Figure 7)
- Q3 - 2N3906 Transistor (see Figure 7)

- ❑ Install the power cord as shown in Figure 9. Pull the power cord wires apart about 2 inches on one end. Strip the insulation off of both wires to expose 1/4" of bare wire. Note that one wire is ribbed on the edge. Solder the red alligator clip to the ribbed wire. Solder the black clip to the round wire. On the other side of the power cord, pull the wires apart 1/2". Strip 1/4" of insulation off of both wires. Make a knot to serve as a strain relief (about 1 inch from the end). Solder the ribbed wire to hole marked "+" and the round wire to the hole marked "-" (see Figure 10).

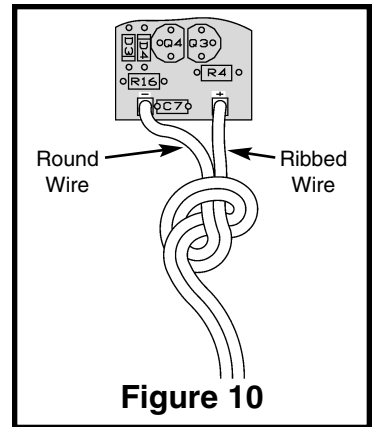
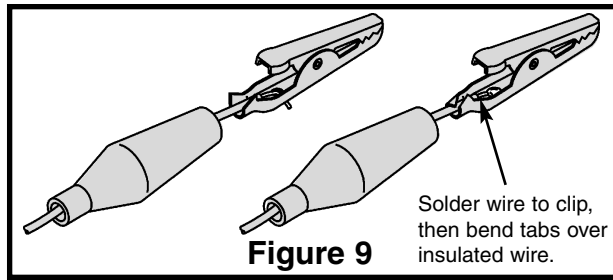

- ❑ Install the probe tip as shown in Figure 11. Using the 1 1/2" wire, strip 1/4" of insulation off of both ends. Solder one end to point P on the PC board. Solder the other end of the wire to the probe tip groove.
- ❑ Install the two labels to the case, as shown in Figure 12. Be careful to place the labels on neatly and correctly. Peel the backing off to expose the glue.
- ❑ Place the PC board assembly into the case as shown in Figure 12. Use two #4 screws to hold the case together. **Do not over-tighten** or the holes may strip out.
- ❑ Cut a 13/16" piece of red shrink tubing and slide it over the probe tip until it touches the plastic case. Shrink the tubing by heating it with your soldering iron. Be sure the soldering iron does not contact the tubing or plastic case.

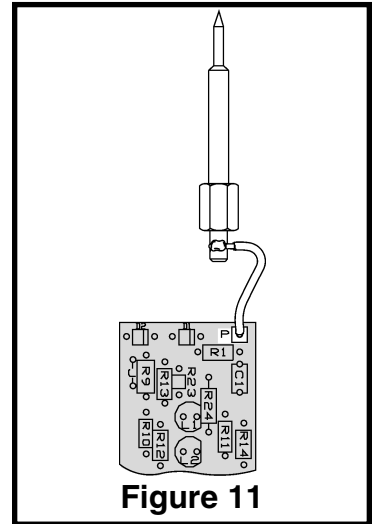

This completes the assembly procedure. Your Logic Probe is now ready for testing.

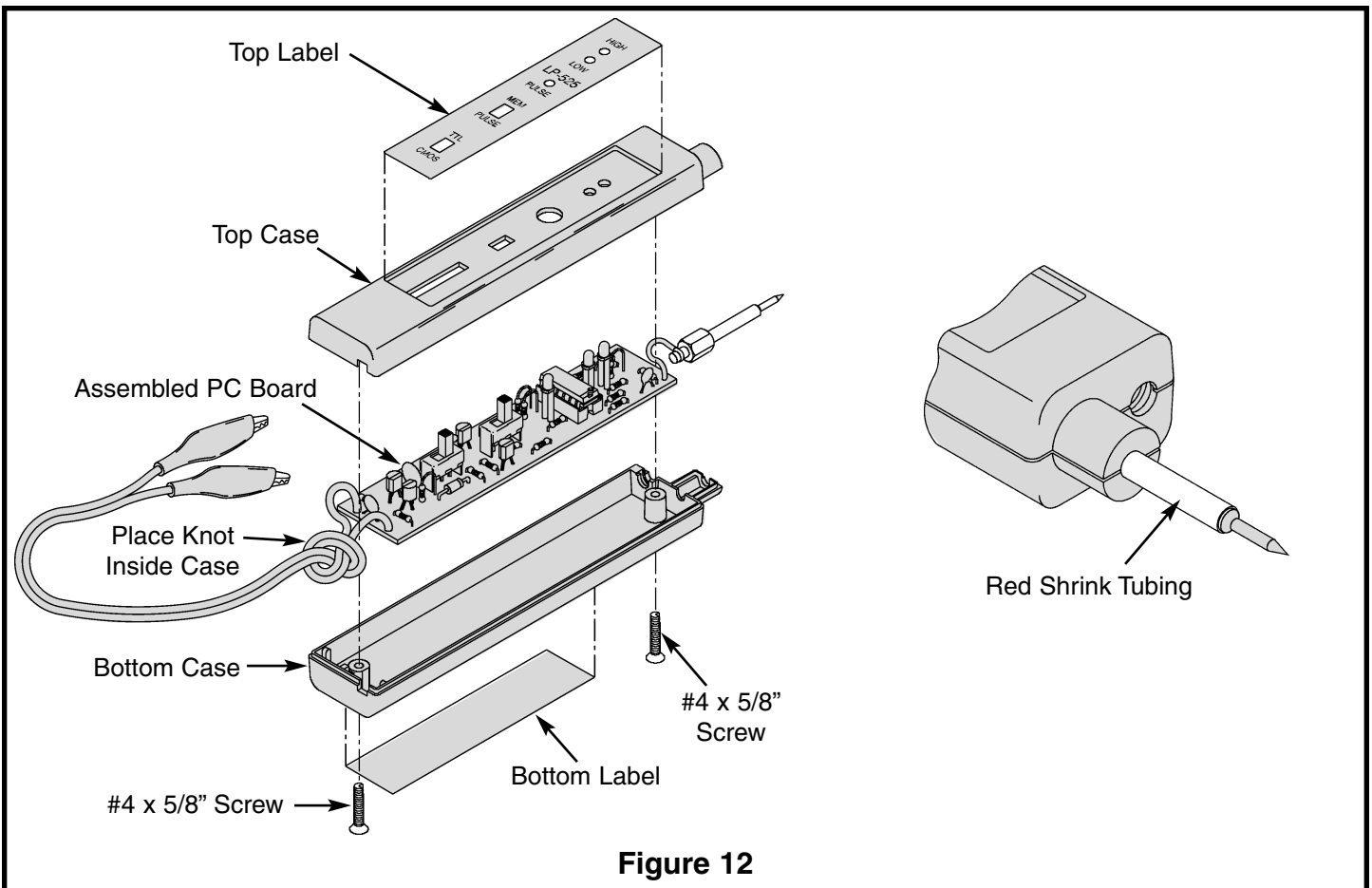

CAUTION: Do not connect the alligator clips to any AC power source or to DC power source greater than 35VDC. Failure to comply to this warning may result in damage to this instrument.

TESTING YOUR DIGITAL PROBE

Checking out your Logic Probe for proper operation is fairly easy. All that is needed is a 9V battery or other DC power source (5-10V). Connect the red alligator clip to the positive terminal of the battery and the black clip to the negative terminal. Set the PULSE-MEM switch to the PULSE position and the TTL-CMOS switch to the TTL position. Touch the probe tip to the positive side of the battery, the PULSE LED should blink once and the HIGH LED should light up. Place the probe tip to the negative terminal and the LOW LED should light up. To check the operation of the memory switch, set the PULSE-MEM switch to the MEM position and set the TTL-CMOS switch to the TTL position. Now touch the probe tip to the positive side of the battery. The PULSE LED should

come on and stay on until the switch is flipped back to the pulse position. No LED's should light up when the tip is not touching anything (open circuit).

The logic probe should operate at the following logic levels when the power supply voltage is precisely set to 5VDC.

| | |
|------------------|---|
| DTL/TTL Position | Logic 0 - under $.8V \pm .1V$ Logic 1 - above $2.3V \pm .25V$ |
| CMOS Position | Logic 0 - under $1.5V \pm .2V$ Logic 1 - above $3.5V \pm .35V$ |

TROUBLESHOOTING CHART

| Condition | Possible Cause |
|-----------------------------------|--|
| No LED's light up. | Power Cord leads reversed. Check U1, C7, or D6. |
| HIGH LED or LOW LED never lights. | Check LED by shorting pins. 1, 2, or 14 to negative supply. Check U1. |
| HIGH or LOW LED always on. | Check U1, R9 to R15. |
| Pulse LED always on. | Check Q3 - Q5, U1. |
| PULSE LED never flashes. | Check LED 3, Q1 - Q4, D3, D4. |
| All LED's flash. | Noise on power line. |

OPERATING INSTRUCTIONS

To operate the logic probe, connect the two alligator clips to the circuit DC power supply, red clip to the positive voltage, black to ground. **BE SURE THE CIRCUIT SUPPLY IS UNDER 35V OR DAMAGE MAY OCCUR TO THE PROBE.** Set the logic family switch to TTL or CMOS. Touch the probe tip to the circuit node to be

analyzed. The LED display on the probe body will light to indicate the condition of the node. Refer to the chart below to interpret the LED readings. To prevent power supply spikes, connect the leads as close to the node to be tested as possible.

Interpreting the LEDs

- LED On
- LED Off
- * LED Blinking

| LED STATES | | | INPUT SIGNAL | |
|------------|----|-------|--------------|---|
| HIGH | LO | PULSE | | |
| ○ | ● | ○ | | Logic "0" no pulse activity. |
| ● | ○ | ○ | | Logic "1" no pulse activity. |
| ○ | ○ | ○ | | All LEDs off 1. Test point is an open circuit. 2. Out of tolerance signal. 3. Probe not connected to power. 4. Node or circuit not powered. |
| ● | ● | * | | Equal brightness of the HI and LO LED indicates approx. a 50% duty cycle square wave. |
| ○ | ○ | * | | High frequency square wave greater than approximately 3MHz. |
| ○ | ● | * | | Logic "0" with positive pulses present. Low duty cycle since HI LED is not on. If duty cycle were increased, the HI LED would start to turn on. |
| ● | ○ | * | | Logic "1" with negative pulses present. High duty cycle since LO LED is not on. If duty cycle were reduced, the LO LED would start to turn on. |

GLOSSARY

| | |
|--|---|
| Alternating Current (AC) | Non-polarized power that is constantly changing back and forth between positive and negative. |
| Anode | The positive terminal of a diode or other polarized component. |
| Capacitor | Electrical component for accumulating energy. |
| Cathode | The negative terminal of a diode or other polarized component. |
| CMOS | (Complimentary Metal Oxide Semiconductor) A type of transistor circuit which uses P- and N-type field-effect transistors. |
| Current | The flow of electrons. |
| Diode | An electronic component that changes alternating current to direct current. |
| Direct Current (DC) | Voltage that has polarity. |
| Frequency | The number of cycles per second produced. |
| Impedance | In circuit, the opposition that circuit elements present to alternating current. |
| Input Impedance | The impedance seen by source when a device or circuit is connected across the source. |
| Integrated Circuit (IC) | Any of a huge number of semiconductor packages that contain entire elements. |
| Inverter | The circuit where the output state is the opposite of the input state. |
| Light Emitting Diode (LED) | A semiconductor device that glows when power is applied to its electrodes. |
| Logic Probe | An electronic test device that detects the status of a signal. |
| Oscillator | A device that moves back and forth between two boundaries. |
| PC Board | Printed Circuit Board. |
| Power Supply | An electronic circuit that produces the necessary power for another circuit or device. |
| Pulse | A sudden change from one level to another, followed after a time by a sudden change back to the original level. |
| Resistor | An electronic component that obstructs (resists) the flow of electricity. |
| Speaker | Component that converts electrical energy into sound energy. |
| Troubleshoot | To find and fix the problem with something. |
| TTL (Transistor-Transistor Logic) | A type of integrated circuit logic that uses bipolar junction transistors. |
| Voltage | The electromotive force that “pushes” electrons through conductive materials. |
| Zener | A type of diode that acts as a voltage regulator by restricting the flow of voltage above its rating. |

SCHEMATIC DIAGRAM

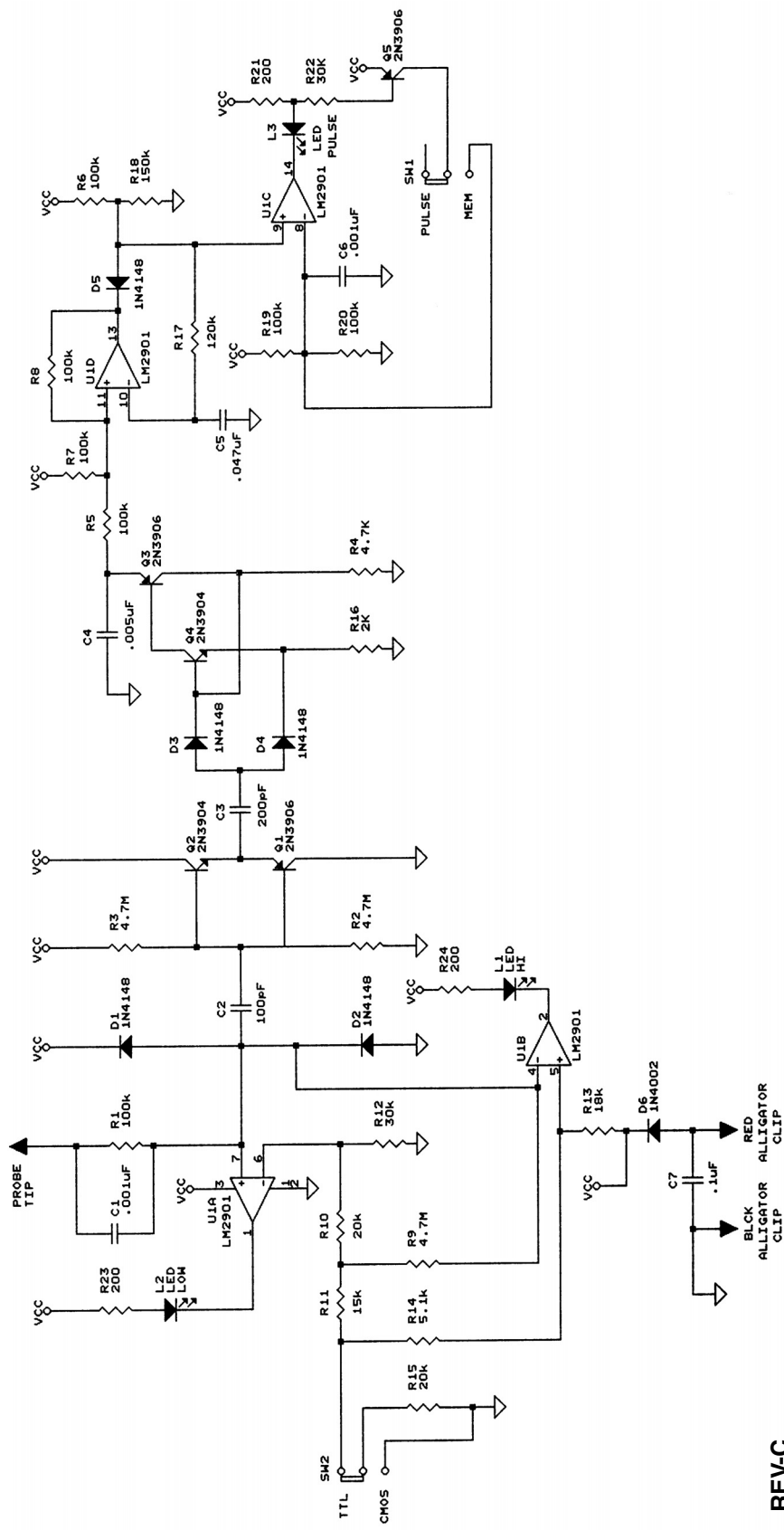

REV-C

ELENCO®

150 Carpenter Avenue • Wheeling, IL 60090
 (847) 541-3800 • www.elenco.com • e-mail: elenco@elenco.com