

POWER SUPPLY

MODEL XP-720



Instruction Manual

ELENCO®

SPECIFICATIONS ON XP-720 POWER SUPPLY

Input Voltage	110-130VAC
Current Protection	1A
Output Voltage (at 120V input)	1) 1.25-15VDC @ 1A 2) -1.25 - -15VDC @ 1A 3) 5VDC @ 3A 4) 6.3, 12.6CTAC @ 1A
Output Regulation	200mV each supply
Line Regulation	100mV each supply
Ripple Max	5mV rms
Current Protection	1A limit 2-15VDC 3A limit 5VDC
Short Protection	1A limit 2-15VDC 3A limit 5VDC
Output Impedance	.025Ω each supply

CAUTION: The maximum output current for the AC section is 1 amp. Overloading the output or shorting the 6.3VAC to ground will damage the transformer.

OPERATING INSTRUCTIONS

1. Check the voltage rating of the equipment to be powered. Care must be taken not to exceed this rating.
2. Plug the line cord into a 120V, 60Hz AC outlet.
3. Adjust the voltage control to desired voltage. Load variation will have practically no effect on the voltage setting due to the special regulation circuit.
4. Connect the positive lead of your equipment to the red output terminal and the negative lead to the black terminal when using the positive supplies. For the negative voltage use the yellow terminal.
5. Care must be taken not to exceed the current reading, as the supplies will turn themselves off if overheated.
6. The Model XP-720 has an added feature of having the positive and negative supplies being able to be stacked to give up to 30V at 1 ampere. Simply use the negative 1.25 to 15V output (yellow jack) as your minus supply connection. For the positive connection, use the positive 1.25 to 15V red terminal. This will allow you to obtain a variable 2.5V to 30V at up to 1 ampere out.

CIRCUIT DESCRIPTION

Introduction

Congratulations on your purchase of a very versatile power supply. Our engineers have carefully designed the XP-720 to give you years of trouble-free performance.

The Model XP-720 Power Supply features three solid-state DC power supplies and a 12.6VAC center-tapped output. The first DC supply gives a variable output of positive 1.25 to 15 volts at up to 1 ampere. The second gives a negative 1.25 to 15 volts at 1 ampere. The third has a fixed 5V at 3 amperes. All DC supplies are fully regulated. A special IC circuit keeps the output voltage within .2V when going from no load to 1 ampere. The output is fully protected from short circuits. This supply is ideal for use in school labs, service shops or anywhere a precise DC voltage is required.

Power Supply

Figure 1 shows a simplified circuit diagram of the positive supply. It consists of a power transformer, a DC rectifier stage and the regulator stage.

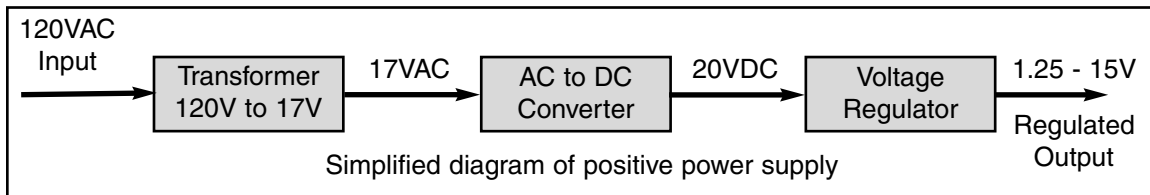

Figure 1

Transformer

The transformer T1 serves two purposes. First, it reduces the 120VAC input to 17VAC and 8VAC to allow the proper voltage to enter the rectifier stages. Second, it isolates the power supply output from the 120VAC line. This prevents the user from dangerous voltage shock, should the user be standing in a grounded area.

AC to DC Converter

The AC to DC converter consists of diodes D1 and D3 and capacitor C5. Transformer T1 has two secondary windings which are 180° out of phase. The AC output at each winding is shown in Figure 2A and 2B.

Diodes are semiconductor devices that allow current to flow in one direction. The arrow in Figure 3 points to the direction that the current will flow. Only when the transformer voltage is positive will current flow through the diodes. Figure 3 shows the simplest possible rectifier circuit. This circuit is known as a half-wave rectifier. Here the diode conducts only half of the time when the AC wave is positive as shown in Figure 2C. Use of this circuit is simple but inefficient. The big gap between cycles require much more filtering to obtain a smooth DC voltage.

By addition of a second diode and transformer winding, we can fill in the gap between cycles as shown in Figure 4. This circuit is called full-wave rectification. Each diode conducts when the voltage is positive. By adding the two outputs, the voltage presented to capacitor C5 is more complete, thus easier to filter, as shown in Figure 2E. When used in 60 cycles AC input power, the output of a full wave rectifier will be 120 cycles.

Capacitor C5 is used to store the current charges, thus smoothing the DC voltage. The larger the capacitor, the more current is stored. In this design, 2200µF capacitors are used, which allows about 3 volts AC ripple when one amp is drawn.

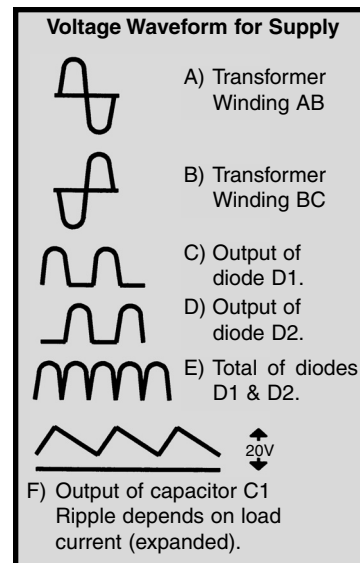

Figure 2

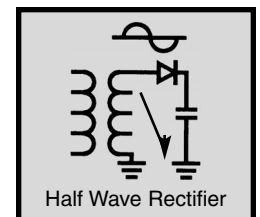

Figure 3

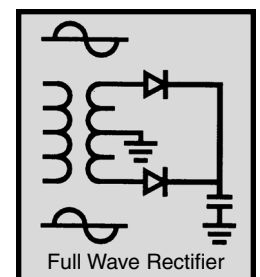

Figure 4

In practice, the current through the diodes is not as shown in Figure 2C. Because capacitor C5 has a charge after the first cycle, the diode will not conduct until the positive AC voltage exceeds the positive charge in the capacitor. Figure 5 shows a better picture of what the current flow looks like, assuming no loss in the diode.

It takes a few cycles for the voltage to build up on the capacitor. This depends on the resistance of the winding and diode. After the initial start-up, there will be a charge and discharge on the capacitor depending on the current drawn by the output load. Remember current only flows through the diode when the anode is more positive than the cathode. Thus, current will flow in short bursts as shown in Figure 5C.



Figure 5

The DC load current may be one ampere, but the peak diode current may be three times that. Therefore, the diode rating must be sufficient to handle the peak current. The 1N4001 has peak current rating of 10 amps.

Regulator Circuit

The regulator circuit in the Model XP-720 Power Supply consists of a LM-317 integrated circuit. This IC is specially designed to perform the regulation function. Figure 6 shows a simplified circuit of how the LM-317 IC works.

Transistors Q1 and Q2 form a circuit known as a differential amplifier. Transistor Q1 base is connected to a stable 1.5V reference voltage. The base of Q2 is connected to the regulator output circuit through a voltage divider network. The collector of transistor Q2 is connected to a current source. This basically is a PNP transistor biased to draw about 1mA of current. Transistor Q2 sees the current source as a very high resistor of about 1 meg ohms. Thus, the gain of transistor Q2 is extremely high.

Transistor Q5 is called the pass transistor. It controls the current reaching the output. Transistors Q3 and Q4 are emitter followers. Their function is to raise the impedance of the pass transistor. Note that transistors Q2, Q3, Q4 and Q5 and resistor R1 form a close loop. Also, note that the feedback to the base of Q2 is negative, that is, when the base of Q2 goes positive, the output at emitter Q5 goes negative. Now if the 2V output voltage goes down because of current drain at the output, the base of Q2 will drop forcing the collector voltage of Q2 to go higher. This will bring the output voltage back to 2V. This is the basis of all negative feedback regulators.

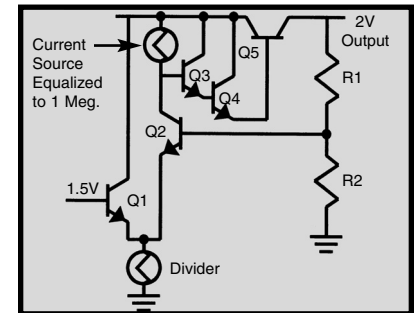

Figure 6

The LM-317 Integrated Circuit

The LM-317 IC is basically a 1.25V regulator. To be able to vary the output 1.25 - 15V, we stack the IC on a DC voltage as shown in Figure 6A. When VR1 equals 0, the output voltage is 1.25V as determined by the LM-317 IC. Note that the voltage across R1 is always 1.25V. When R1 equals VR1, the voltage across VR1 will equal the 1.25V across R1, therefore, the output voltage will be 2.5V. When VR1 is 5 times R1, the output voltage is 6.25V. As you can see, varying resistor VR1 will vary the voltage from 1.25V to 15V.

Another feature of the LM-317 regulator is to protect the IC against overload and output shorts. If the IC is overloaded, the junction of an overload transistor will overheat. A transistor will sense this overheating and shut down transistor Q5.

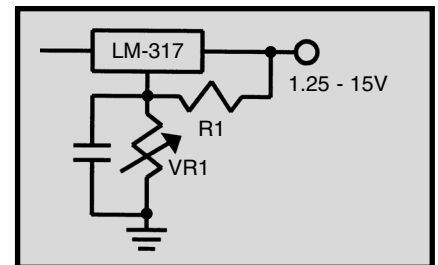

Figure 6A

The Negative Voltage Regulator

The theory of the negative voltage regulator is the same as the previously discussed positive regulator. The basic differences is that diodes D2 and D4 are reversed, producing a negative voltage across capacitor C6. The LM-317 IC is designed to operate from a negative supply.

The 5 Volt Power Supply

In the previous discussion of the variable voltage regulators, the ICs can handle about 1A of current. In the design of the 5V supply, we need 3A of current. To meet this current requirement, we must add an external pass transistor capable of delivering 3A.

Figure 7 shows a simplified 5V regulator with an external PNP pass transistor. In this circuit, transistor Q1 is a power transistor capable of delivering over 3A. Transistor Q2 is biased off until the LM-7805 IC draws about .2A. When .2A is drawn by the LM-7805 IC, the voltage drop across the 3 ohm resistor is .6V, enough to turn on transistor Q2. Transistor Q2 takes over and delivers the current to the output. Note that if the output voltage goes down, the LM-7805 regulator will draw more current, forcing the output voltage back to 5V. Thus, the LM-7805 regulator controls the output voltage and keeps it at 5V.

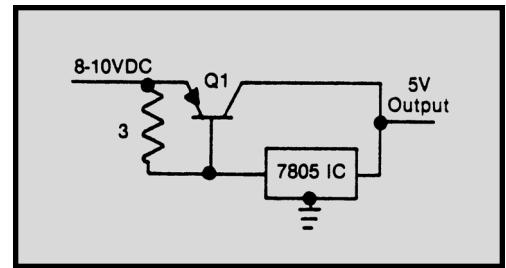

Figure 7

Unfortunately, this circuit has no control of the output maximum current.

If the output is shorted to ground transistor Q2 will be overloaded and eventually be damaged. The LM-7805 IC will only draw the .2A it was designed to handle and never heat up to turn itself off. Another transistor, Q1, is added to limit maximum current. Resistor R5 is added to sense the current in transistor Q2. When approximately 3A is drawn in transistor Q2, the voltage drop in resistor R5 will turn on transistor Q1. This will force more current in the LM-7805 IC. Eventually the LM-7805 IC will overheat turning itself off and thus limiting the circuit at about 2.6A.

The first .2A of current is drawn by the LM-7805 IC. The next 3A are drawn by transistor Q2. Thereafter, the current is drawn by the LM-7805 IC until it overheats and turns itself off. This is a very effective circuit capable of regulating the output voltage at a constant 5 volts and yet delivering over 3A of current.

AC Power Supply

The section features a 12.6VAC center-tapped output. Two secondary windings from the transformer are connected directly to the yellow binding posts. Connecting from one of the outputs to the center black binding post will give you 6.3VAC. The maximum output current for 12.6VAC and 6.3VAC is 1A.

WARRANTY POLICY

Your power supply has been tested and conforms to our rigid requirements on performance and durability. It is guaranteed to be free of defects in workmanship, materials and construction for a period of 2 years. If this product should fail during normal use within the first 3 months from the date of purchase, Elenco® will repair or replace the unit at no cost. For the remainder of the warranty period, a nominal service charge is required to cover shipping and handling.

When returning merchandise for repair, please include proof of purchase, a brief letter of explanation of problem and sufficient packing material. Before returning any merchandise, please call our service department at (847) 541-3800 to obtain a return authorization number (RA).

ELENCO® Service Department
150 Carpenter Avenue Wheeling, IL 60090

PARTS LIST

Qty.	Description	Part #	Qty.	Description	Part #
RESISTORS					
□ 1	0.18Ω 3W	101804	□ 2	Knob	622009
□ 2	2.7Ω 1/2W (red-violet-gold-gold)	112701	□ 1	Strain relief	624003
□ 2	150Ω 1/4W (brn-green-brn-gold)	131500	□ 5	Bushing	624007
□ 2	2kΩ Potentiometer	192422	□ 4	PC board stand-off	625001
CAPACITORS					
□ 5	10μF Electrolytic	271045	□ 2	Black binding post	625031
□ 2	2,200μF Electrolytic	292226	□ 7	Lockwasher	625031LW
□ 1	4,700μF Electrolytic	294744	□ 7	Nut	625031HN
SEMICONDUCTORS					
□ 4	1N4001 Diode	314001	□ 2	Red binding post	625032
□ 4	1N5400 Diode	315400	□ 3	Yellow binding post	625034
□ 1	MPSA70 Transistor	320070	□ 3	Cable ties	628982
□ 1	2N6124 Transistor	326124	□ 5	Screw 6-32 x 3/8"	641640
□ 1	LM-317 IC	330317	□ 2	Screw 8-32 x 3/8"	641840
□ 1	LM-337 IC	330337	□ 4	Screw 6 x 3/8" black	642652
□ 1	LM-7805 IC	337805	□ 2	Screw 6 x 3/8" black	642660
MISCELLANEOUS					
□ 1	Transformer	440720	□ 2	Nut 7mm	644101
□ 1	PC board	512013	□ 1	Nut 6-32	644600
□ 1	Fuse 1A	530100	□ 4	Nut 6-32 small	644601
□ 1	Rocker switch	541204	□ 2	Nut 8-32	644800
□ 1	Cover	611120	□ 2	Flat washer 8mm x 14mm	645101
□ 1	Chassis	612012	□ 2	Lockwasher 5/16"	646101
□ 1	Heat sink	615010	□ 3	Lockwasher #8	646828
			□ 4	Rubber feet	662003
			□ 1	Fuse holder (lower body)	663005LB
			□ 1	Fuse holder (nut)	663005N
			□ 1	Fuse holder (upper body)	663005UB
			□ 1	Fuse holder (washer)	663005W
			□ 3	Mica insulator	780002
			□ 1	Line cord	862105

SCHEMATIC DIAGRAM

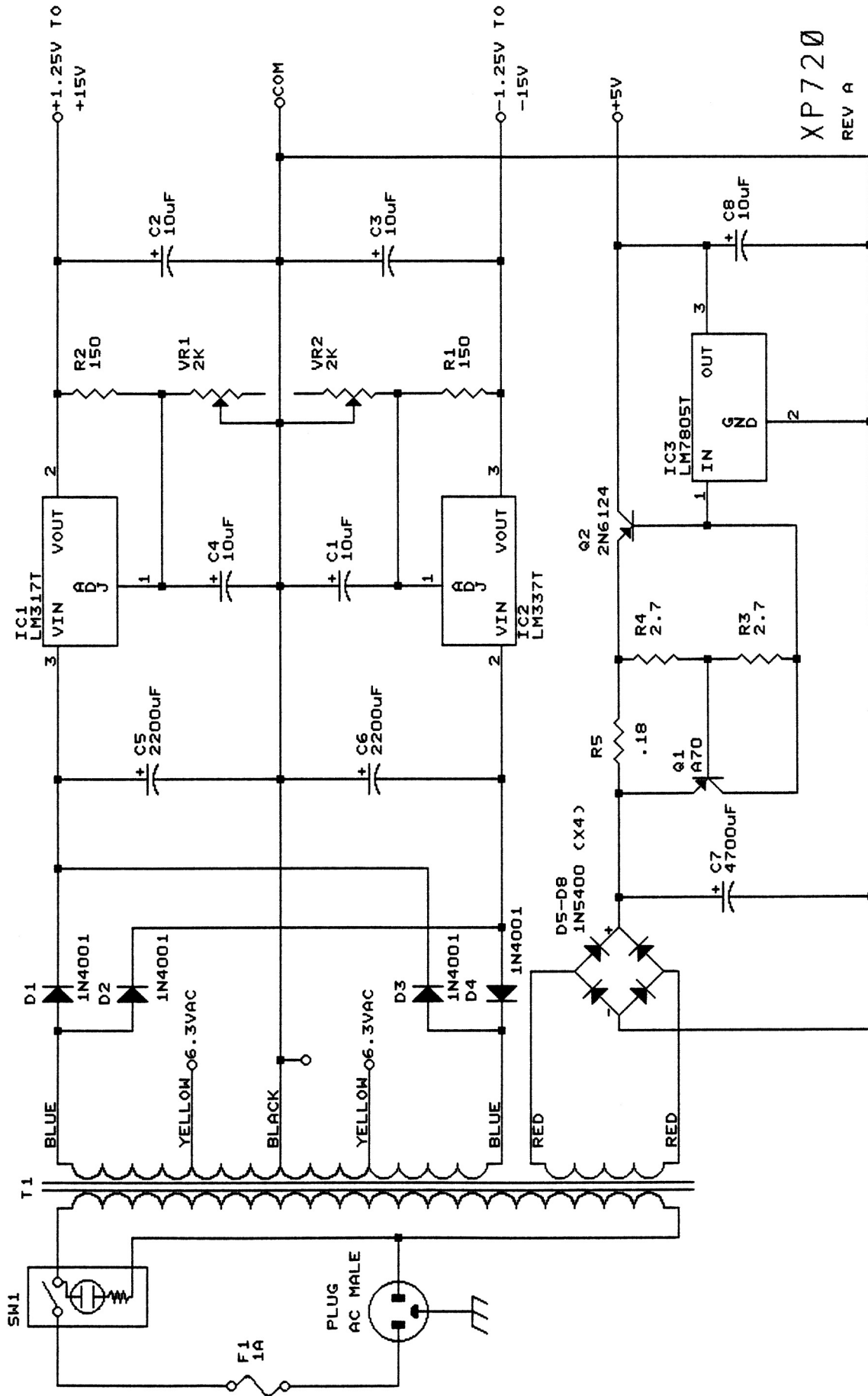

XP720
REV A

ELENCO®

150 Carpenter Avenue

Wheeling, IL 60090

(847) 541-3800

Website: www.elenco.com

e-mail: elenco@elenco.com