

Bonus Motion Detector Circuits

These circuits require the motion detector parts (motion detector U7 and 9V battery holder & switch B5) along with the SC-300 (300 experiments) or larger parts set.

The motion detector parts are available only in the SCP-03 Motion Detector Kit or through the replacement parts order form. More information about these parts is available at http://www.snapcircuits.net/IC_SCP03.pdf. You can view the manuals for the SCP-03 at www.elenco.ws, and select SCP-03.

Project #MD1 Motion Alarm & Lights

OBJECTIVE: To signal when motion is detected in a room.

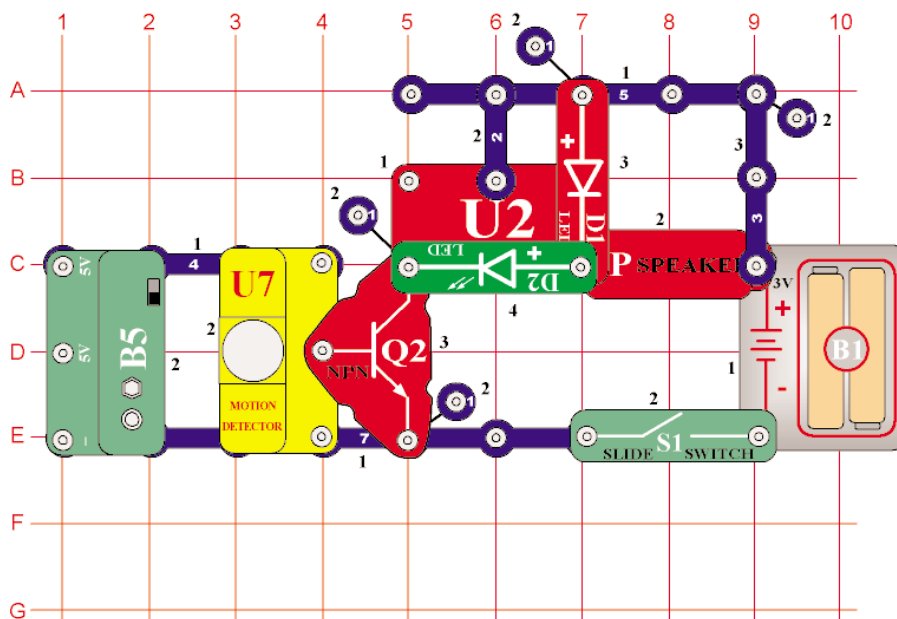

Requires the motion detector parts and an SC-300 or larger parts set.

Turn on the slide switch (S1) and the switch on the 9V battery holder (B5.) You hear an alarm sound and see lights for a few seconds on start-up and then whenever the circuit detects motion in the room.

Option A:

Replace the speaker (SP) with the 2.5V lamp (L1). The circuit works the same way but doesn't make any noise.

Option B:

Replace the speaker (SP) with the whistle chip (WC) and remove the green LED (D2). The circuit is not as loud as before.

Option C:

Replace the alarm IC (U2) with the music IC (U1). The circuit works the same way but plays a different tune.

Project #MD2

Motion Music

OBJECTIVE: To signal when motion is detected in a room.

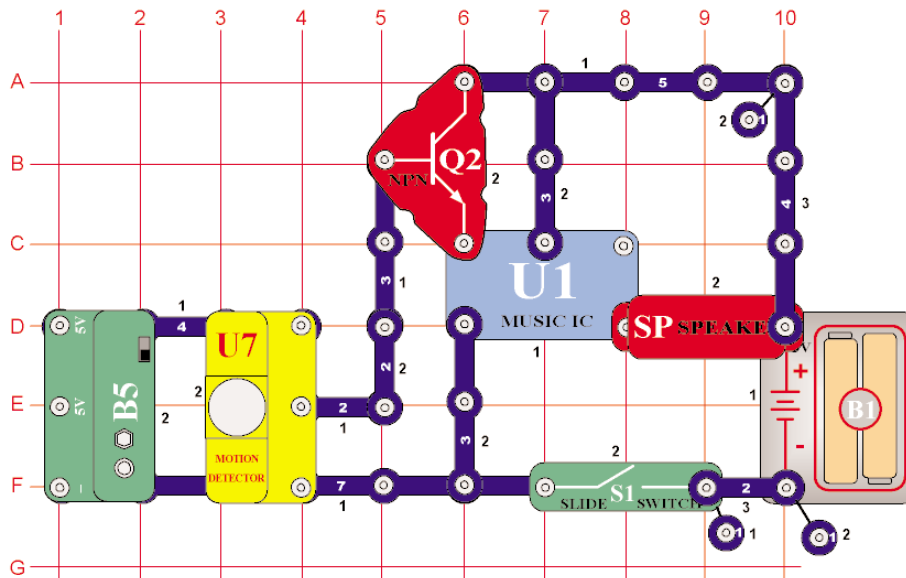

Turn the slide switch (S1) and the switch on the 9V battery holder (B5). You hear a musical melody on start-up and then whenever the circuit detects motion in the room.

Option A:

Replace the speaker (SP) with the whistle chip (WC). Then add the green LED (D2) across the whistle chip on level 4 ("+" on the right), using a 1-snap under the left side. The circuit works the same way, but the music is not as loud and the LED is blinking.

Requires the motion detector parts and an SC-300 or larger parts set.

Project #MD3

Motion Lights

OBJECTIVE: To connect multiple devices together.

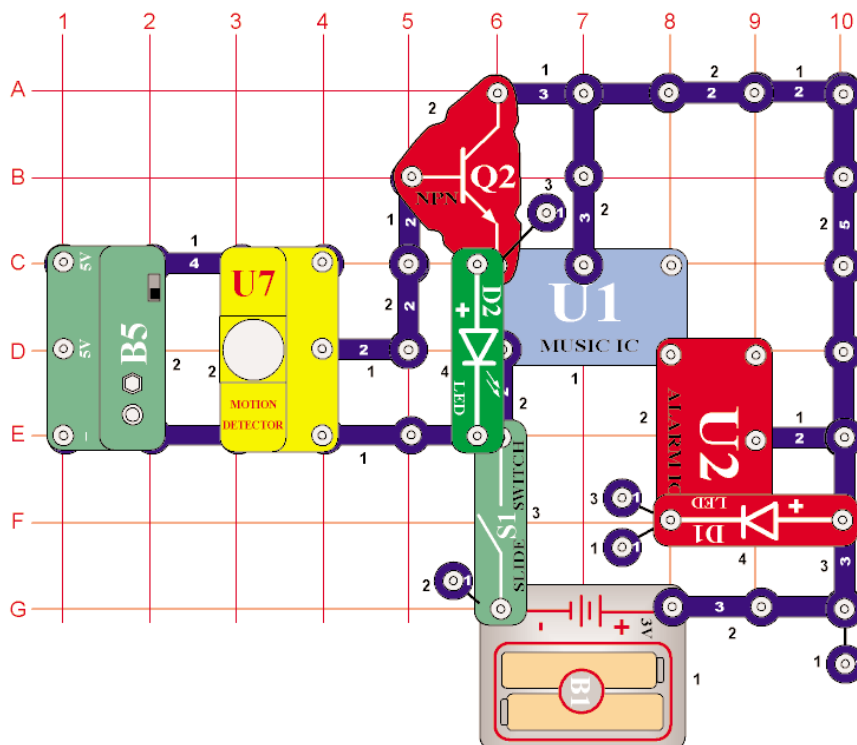

Turn on the slide switch (S1) and the switch on the 9V battery holder (B5). The green LED (D2) turns on for a few seconds and the red LED (D1) turns on for longer. When the motion sensor detects motion in the room the LEDs turn on again.

Requires the motion detector parts and an SC-300 or larger parts set.

Project #MD4 Daytime Motion Detector

OBJECTIVE: To signal when motion is detected in a bright room.

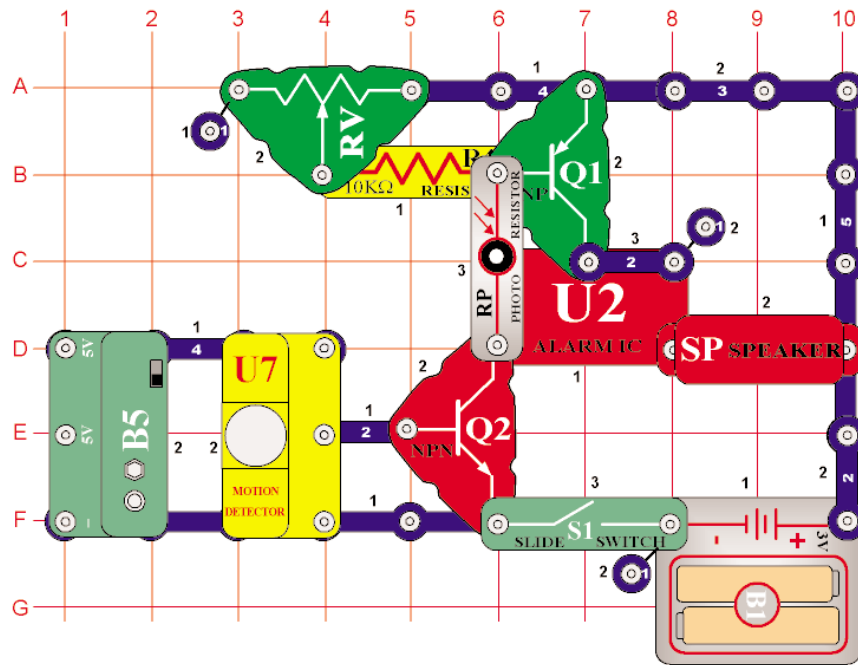

Requires the motion detector parts and an SC-300 or larger parts set.

Turn the slide switch (S1) and the switch on the 9V battery holder (B5). If there is a lot of light in the room then you hear a laser sound for a few seconds and then whenever the circuit detects motion in the room. Tune the adjustable resistor (RV) to adjust the light sensitivity of the photoresistor (RP).

Option A:
Replace the speaker (SP) with the whistle chip (WC). Then add the green LED (D2) across the whistle chip on level 3 ("+" on the right). The circuit works the same way, but the music is not as loud and the LED lights.

Option B:
Replace the green LED (D2) with the 2.5V lamp (L1).

Project #MD5 Nighttime Motion Detector

OBJECTIVE: To signal when motion is detected in a dark room.

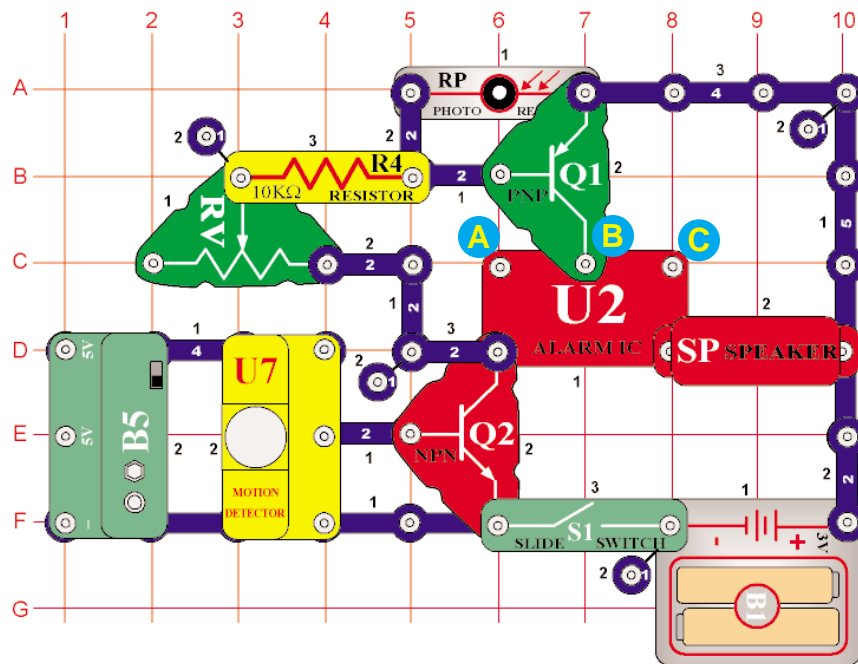

Turn the slide switch (S1) and the switch on the 9V battery holder (B5). If the room is dark then you hear an alarm sound for a few seconds and then whenever the circuit detects motion in the room. Tune the adjustable resistor (RV) to adjust the light sensitivity of the photoresistor (RP).

Option A:
Change the alarm sound by placing a 1-snap on point A and a 2-snap across points A-B, OR a 1-snap on point C and a 2-snap across points B-C.

Requires the motion detector parts and an SC-300 or larger parts set.

Project #MD6 Nighttime Motion Detector (II)

OBJECTIVE: To signal when motion is detected in a dark room.

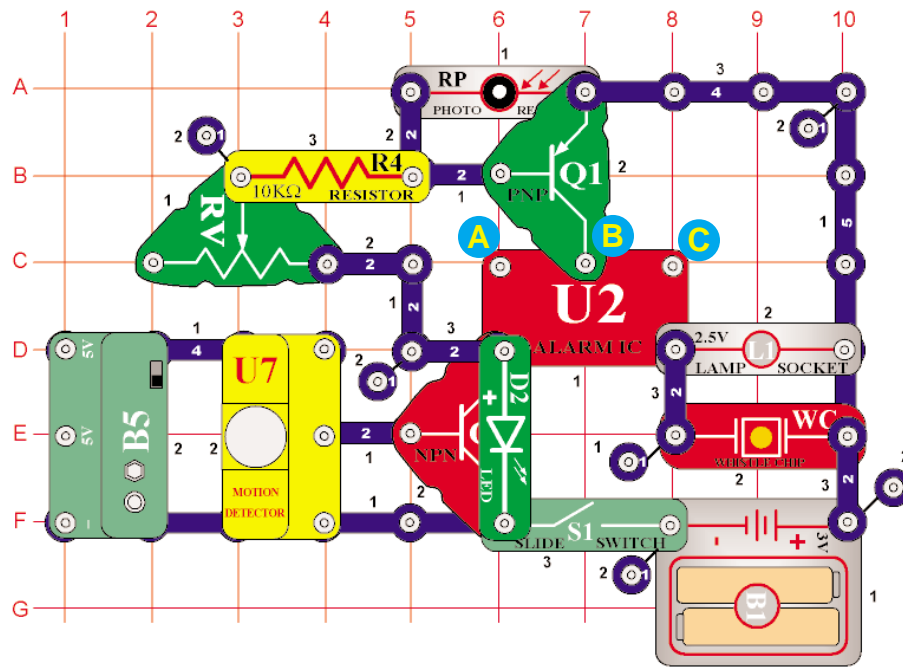

Turn the slide switch (S1) and the switch on the 9V battery holder (B5). If the room is dark then you hear an siren sound for a few seconds and then whenever the circuit detects motion in the room. The green LED (D2) lights when the room is dark and the motion sensor is ready. Tune the adjustable resistor (RV) to adjust the light sensitivity of the photoresistor (RP).

Option A:
Change the alarm sound by placing a 1-snap on point A and a 2-snap across points A-B, OR a 1-snap on point C and a 2-snap across points B-C.

Requires the motion detector parts and an SC-300 or larger parts set.

Project #MD7 Motion Space Attack

OBJECTIVE: To play sounds when motion is detected in a room.

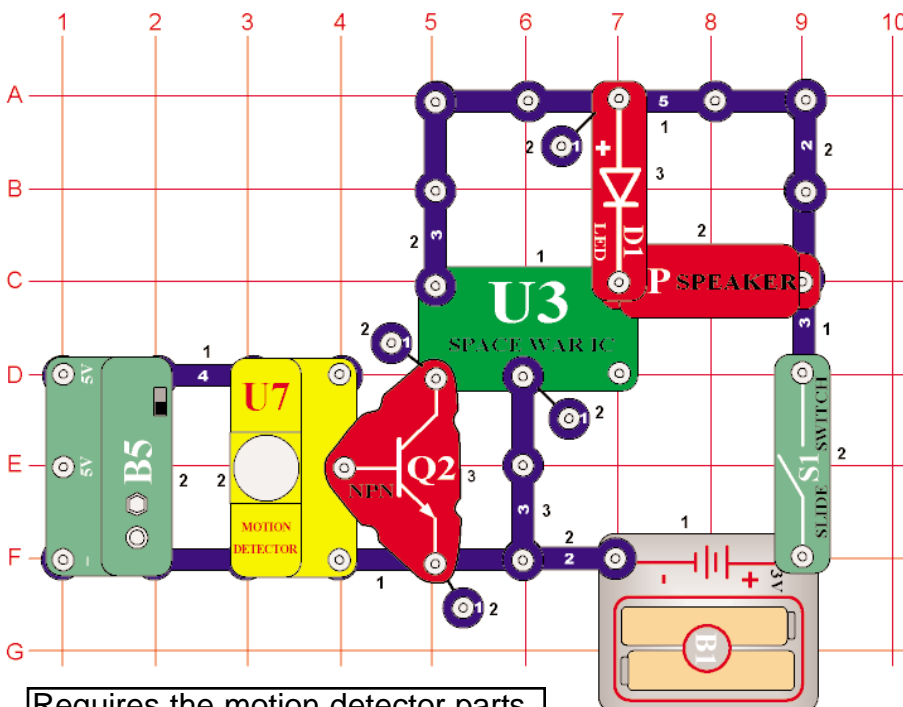

Turn the slide switch (S1) and the switch on the 9V battery holder (B5), you hear a space war sound for a few seconds. Each time the circuit detects motion in the room it activates a different sound, like a space attack.

Requires the motion detector parts and an SC-300 or larger parts set.

Project #MD8

Motion Bomber

OBJECTIVE: To signal when motion is detected in a room.

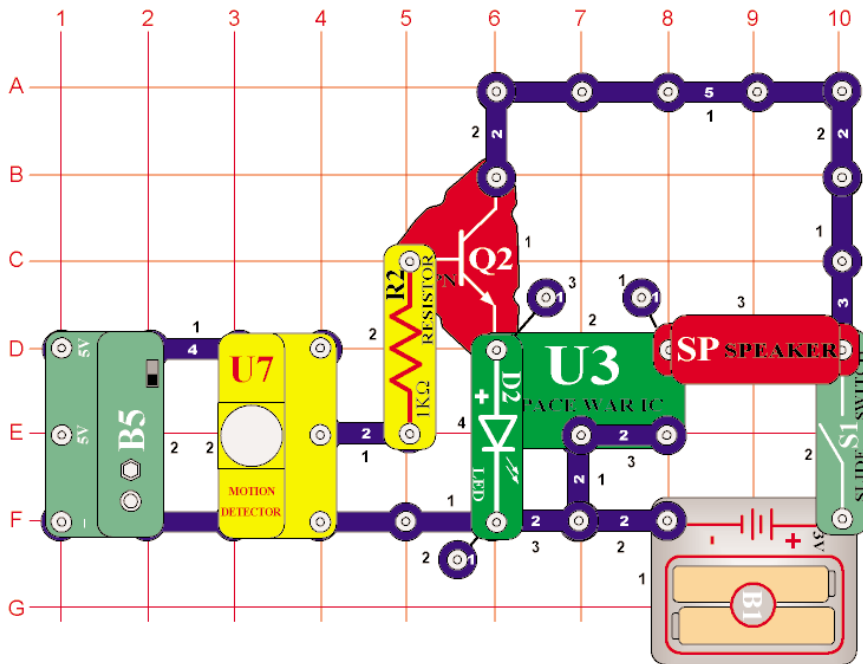

Turn the slide switch (S1) and the switch on the 9V battery holder (B5). You hear a bomb sound on start-up and then whenever the circuit detects motion in the room.

Requires the motion detector parts and an SC-300 or larger parts set.

Project #MD9

Motion Tone

OBJECTIVE: To signal when motion is detected in a room.

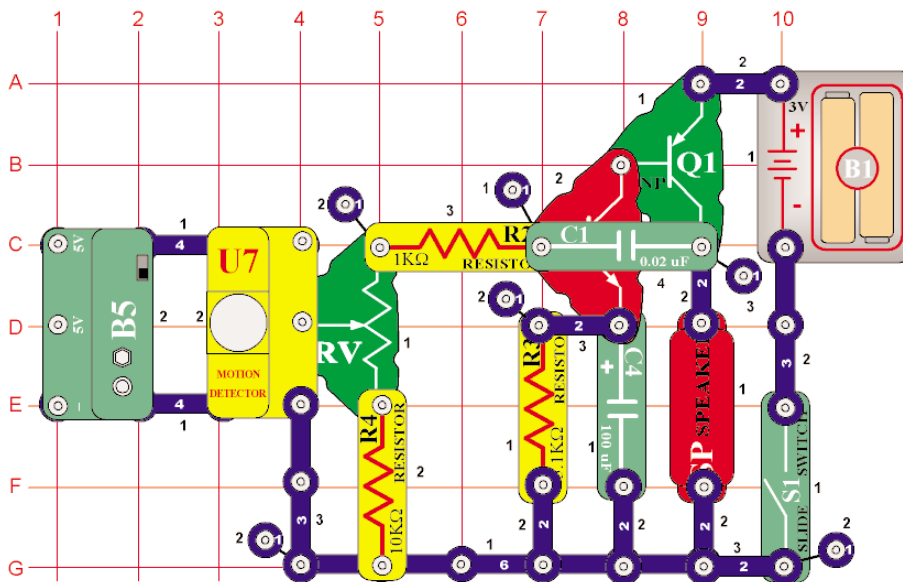

Turn the slide switch (S1) and the switch on the 9V battery holder (B5). You hear a tone on start-up and then whenever the circuit detects motion in the room. Use the lever on the adjustable resistor (RV) to adjust the frequency of the tone.

Option A:
Replace the 0.02μF capacitor (C1) with the 0.1μF capacitor (C2). The sound is lower in frequency now.

Option B:
Replace 0.1μF capacitor (C2) with the 10μF capacitor (C3, (+) side towards the right). Now it makes a clicking sound.

Requires the motion detector parts and an SC-300 or larger parts set.

Project #MD10

Motion Lights (II)

OBJECTIVE: To signal when motion is detected in a room.

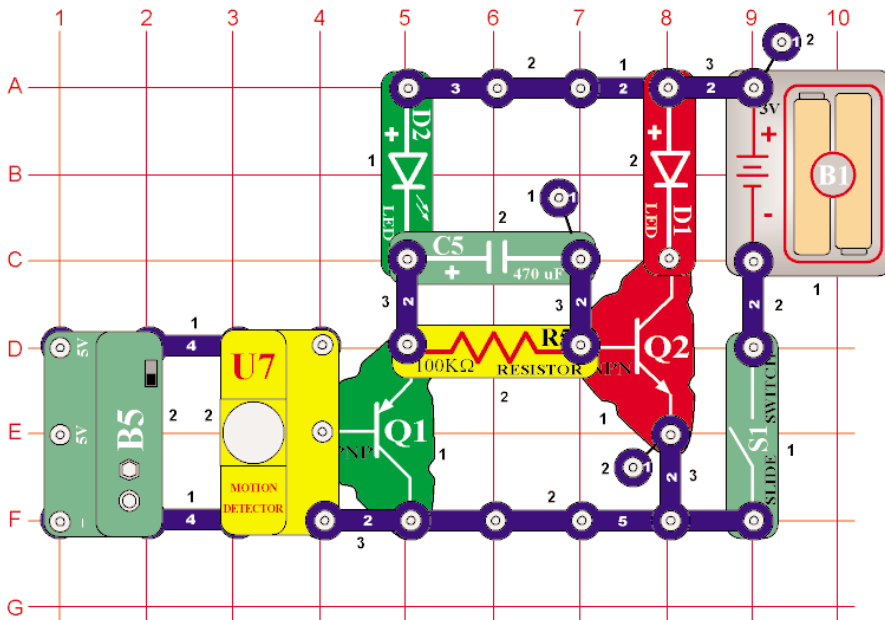

Turn the slide switch (S1) and the switch on the 9V battery holder (B5). The red LED (D1) comes on whenever the circuit detects motion in the room. The green LED (D2) lights when the motion sensor is ready to detect again.

Requires the motion detector parts and an SC-300 or larger parts set.

Project #MD11

Motion Motor

OBJECTIVE: To signal when motion is detected in a room.

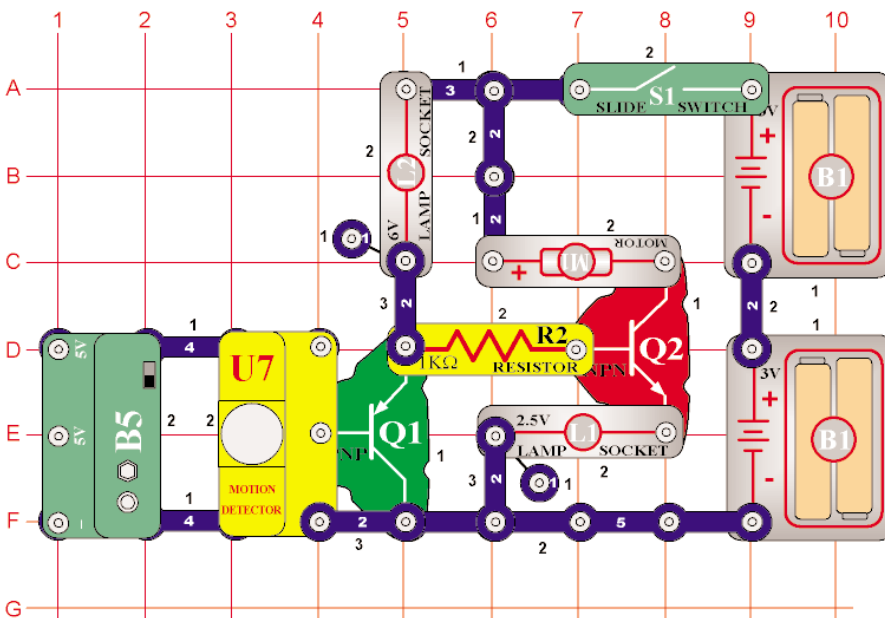

Place the fan on the motor. Turn on the slide switch (S1) and the switch on the 9V battery holder (B5). The fan spins and the 2.5V lamp lights for a few seconds, then again when motion is detected in the room. The 6V lamp lights when the motion sensor is ready to detect again.

Requires the motion detector parts and an SC-300 or larger parts set.