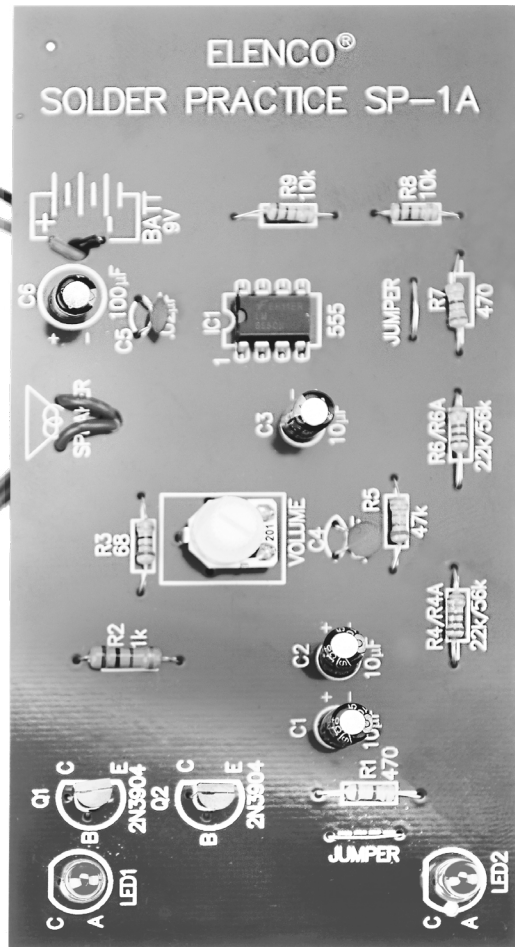


# SOLDER PRACTICE KIT

## MODEL SP-1A



7 56619 00033 6



### Assembly and Instruction Manual



**ELENCO®**



**WARNING:** Cancer and Reproductive Harm  
[www.P65Warnings.ca.gov](http://www.P65Warnings.ca.gov).

## PARTS LIST

If you are a student, and any parts are missing or damaged, please see instructor or bookstore.

If you purchased this kit from a distributor, catalog, etc., please contact ELENCO® (address/phone/e-mail is at the back of this manual) for additional assistance, if needed. **DO NOT** contact your place of purchase as they will not be able to help you.

### RESISTORS

**Note:** Please refer to page 3 for the resistor reading exercise. This will familiarize you with the resistor color band coding.

Qty.	Symbol	Value	Color Code	Part #
□ 1	R3	68Ω 5% 1/4W	blue-gray-black-gold	126800
□ 2	R1, R7	470Ω 5% 1/4W	yellow-violet-brown-gold	134700
□ 1	R2	1kΩ 5% 1/2W	brown-black-red-gold	141001
□ 2	R8,R9	10kΩ 5% 1/4W	brown-black-orange-gold	151000
□ 2	R4, R6	22kΩ 5% 1/4W	red-red-orange-gold	152200
□ 1	R5	47kΩ 5% 1/4W	yellow-violet-orange-gold	154700
◆ □ 2	R4A, R6A	56kΩ 5% 1/4W	green-blue-orange-gold	155600
□ 1	VR1	200Ω Trim Pot		191321

◆ See Desoldering Practice, page 13

### CAPACITORS

Qty.	Symbol	Value	Description	Part #
□ 2	C4, C5	0.02μF (203) or 0.022μF (223)	Discap	242010
□ 3	C1, C2, C3	10μF	Electrolytic (Lytic)	271045
□ 1	C6	100μF	Electrolytic (Lytic)	281044

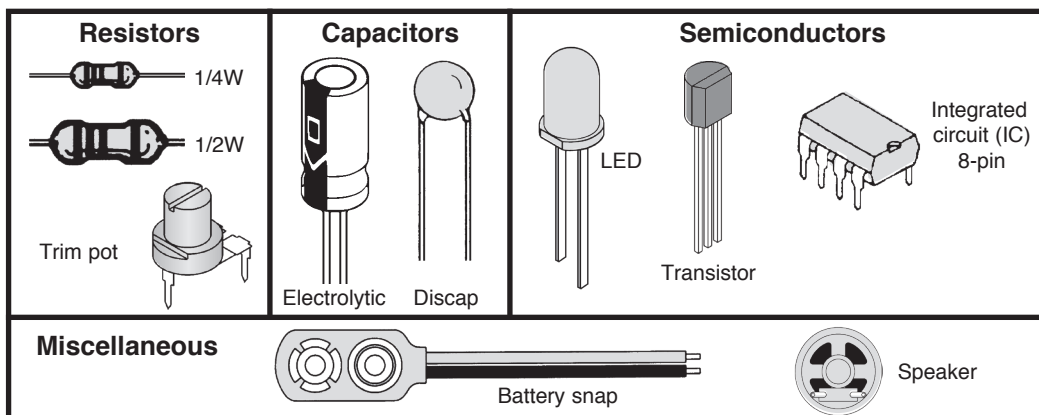
### SEMICONDUCTORS

Qty.	Symbol	Value	Description	Part #
□ 2	Q1, Q2	2N3904	Transistor NPN	323904
□ 1	IC1	555 or 1455	Integrated circuit (timer)	330555
□ 2	LED1, LED2	Red	LED (light emitting diode)	350002

### MISCELLANEOUS

Qty.	Symbol	Description	Part #
□ 1		PC board	511500
□ 1		Solder wick	556000
□ 1		Battery snap	590098
□ 1		Speaker	590102
□ 1		Wire 22AWG solid 3'	834064
□ 1		Solder tube lead-free	9LF99

## PARTS IDENTIFICATION



### Batteries:

- Do not short circuit the battery terminals.
- Never throw batteries in a fire or attempt to open its outer casing.
- Use only 9V type alkaline battery (not included).
- Insert battery with correct polarity.
- Do not mix alkaline, standard (carbon-zinc), or rechargeable (nickel-cadmium) batteries.
- Non-rechargeable batteries should not be recharged. Rechargeable batteries should only be charged under adult supervision, and should not be recharged while in the product.
- Remove battery when it is used up.
- Batteries are harmful if swallowed, so keep away from small children.

## IDENTIFYING RESISTOR VALUES

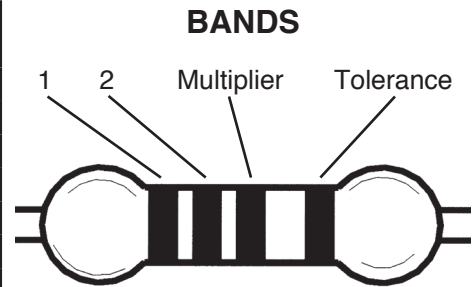
Use the following information as a guide in properly identifying the value of resistors.

BAND 1 1st Digit	
Color	Digit
Black	0
Brown	1
Red	2
Orange	3
Yellow	4
Green	5
Blue	6
Violet	7
Gray	8
White	9

BAND 2 2nd Digit	
Color	Digit
Black	0
Brown	1
Red	2
Orange	3
Yellow	4
Green	5
Blue	6
Violet	7
Gray	8
White	9

Multiplier	
Color	Multiplier
Black	1
Brown	10
Red	100
Orange	1,000
Yellow	10,000
Green	100,000
Blue	1,000,000
Silver	0.01
Gold	0.1

Resistance Tolerance	
Color	Tolerance
Silver	±10%
Gold	±5%
Brown	±1%
Red	±2%
Orange	±3%
Green	±0.5%
Blue	±0.25%
Violet	±0.1%



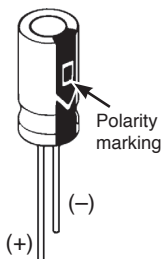
## IDENTIFYING CAPACITOR VALUES

Capacitors will be identified by their capacitance value in pF (picofarads), nF (nanofarads), or  $\mu$ F (microfarads). Most capacitors will have their actual value printed on them. Some capacitors may have their value printed in the following manner. The maximum operating voltage may also be printed on the capacitor.

Electrolytic capacitors have a positive and a negative electrode. The negative lead is indicated on the packaging by a stripe with minus signs and possibly arrowheads. Also, the negative lead of a radial electrolytic is shorter than the positive one.

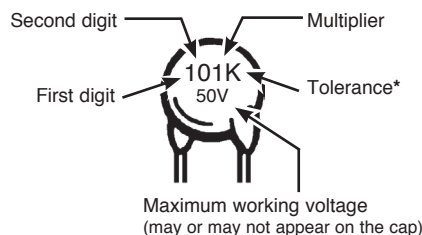
### Warning:

If the capacitor is connected with incorrect polarity, it may heat up and either leak, or cause the capacitor to explode.



Multiplier	For the No.	0	1	2	3	4	5	8	9
	Multiply By	1	10	100	1k	10k	100k	.01	0.1

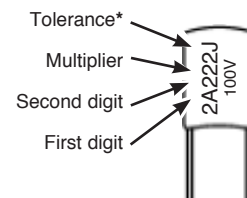
### CERAMIC DISC



The value is  $10 \times 10 = 100\text{pF}$ ,  $\pm 10\%$ , 50V

The letter J indicates a tolerance of  $\pm 5\%$   
 The letter K indicates a tolerance of  $\pm 10\%$   
 The letter M indicates a tolerance of  $\pm 20\%$   
 The letter Z indicates a tolerance of  $+80\% -20\%$

### MYLAR



The value is  $22 \times 100 = 2,200\text{pF}$  or  $.0022\mu\text{F}$ ,  $\pm 5\%$ , 100V

**Note:** The letter "R" may be used at times to signify a decimal point; as in 3R3 = 3.3

## METRIC UNITS AND CONVERSIONS


Abbreviation	Means	Multiply Unit By	Or
p	Pico	.000000000001	$10^{-12}$
n	nano	.000000001	$10^{-9}$
$\mu$	micro	.000001	$10^{-6}$
m	milli	.001	$10^{-3}$
-	unit	1	$10^0$
k	kilo	1,000	$10^3$
M	mega	1,000,000	$10^6$

1. 1,000 pico units = 1 nano unit
2. 1,000 nano units = 1 micro unit
3. 1,000 micro units = 1 milli unit
4. 1,000 milli units = 1 unit
5. 1,000 units = 1 kilo unit
6. 1,000 kilo units = 1 mega unit


# RESISTOR READING EXERCISE

Before starting assembly of your solder practice project, you should be thoroughly familiar with the 4-band color code system. Many of the resistor values will be identified by color bands and it is easy to mistake their value if you read the colors incorrectly or read the value from the wrong end. Do the following exercise in resistor values. Place your answer in the box beneath the resistor. Answers are on the bottom of this page.


(1) brown-green-red-gold




(2) brown-black-orange-gold




(3) brown-black-yellow-gold




(4) red-red-orange-gold




(5) yellow-violet-brown-gold




(6) blue-gray-orange-gold




(7) yellow-violet-black-gold




(8) brown-blue-brown-gold




(9) orange-orange-red-gold




(10) green-brown-red-gold



(11) brown-black-green-gold



(12) brown-gray-orange-gold



Answers to Resistor Reading Exercise: (1) 1.5kΩ±5%; (2) 10kΩ±5%; (3) 100kΩ±5%; (4) 22kΩ±5%; (5) 470Ω±5%; (6) 68kΩ±5%; (7) 47Ω±5%; (8) 160Ω±5%; (9) 3.3kΩ±5%; (10) 5.1kΩ±5%; (11) 1MΩ±5%; (12) 18kΩ±5%

## INTRODUCTION

Almost every electronic device today has a printed circuit board. Whether you are assembling a PC board or repairing it, you must understand the basics of working with these boards.

Good soldering requires practice and an understanding of soldering principles. This solder practice project will help you achieve good soldering techniques, help you to become familiar with a variety of electronic components, and provide you with dynamic results. If the circuit has been assembled and soldered properly, two LEDs will alternately flash, and the speaker will produce a wailing sound.

## Safety Precautions

Like all electrical devices, the solder station must be handled with care. The soldering iron and tip can reach high temperatures and these simple safety rules should be followed.

- Keep children out of reach of the soldering station.
- To protect your eyes, use safety goggles during all phases of construction.
- Keep flammable material away from the soldering iron.
- **DO NOT cool iron** by dipping it into any liquid or water.
- Always assume that the tip is hot to avoid burns.
- Work in an area that is well ventilated.
- Be careful that the hot soldering iron tip or the barrel of the iron does not come in contact with any electrical cord.
- **Do not hold solder in your mouth.** Wash your hands thoroughly after handling solder.
- Locate soldering iron in an area where you do not have to go around it or reach over it.

## Solder

Solder is a fusible metal, ideal for forming a metallic joint between two metals. Lead solder is composed of tin and lead, identified by the ratio of tin-to-lead. The most common ratios are 63/37, 60/40, the first number indicates the amount of tin, and the second is lead. It has a melting temperature around 360° to 370°.

For health reasons, lead-free solder is widely used and included in this kit. Lead-free solders contain high percentages of tin, almost always over 94%. The lead-free solder in this kit contains 99.3% tin, 0.5% copper, and has a rosin-flux core. The melting point of lead-free solder is about 40°F higher than leaded solder.

Tin is a corrosive and active metal and when it mixes with iron (the protective layer on the tip), an inter-metallic compound is formed that wears away more

quickly than the iron would either by itself or when used with leaded solder.

When using lead-free solders it is very important that tips are properly maintained, otherwise tip life will be reduced significantly. Tips should be cleaned frequently to remove oxidation before it becomes impossible to remove. The tips should always be tinned when not being used, otherwise oxidation will quickly form on the tip. The iron should be turned off if not used for extended periods of time.

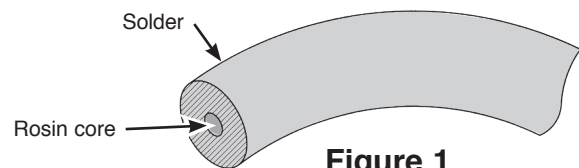


Figure 1

## Flux

Most solder contains flux in the hollow core of the solder allowing it to be applied automatically when you heat the solder. The flux will remove any oxide film on the metals soldered creating a good metal-to-metal contact. This is called “wetting the metal”. There are three types of solder fluxes: chloride, organic and rosin. In the electronics industry, only the rosin type is used. Rosin flux comes in two types, pure and active. The most reliable is the pure type, since it doesn’t cause dendrites between tracks on the PC board as the active type does. Due to the highly corrosive and moisture attracting characteristics of the chloride and organic type fluxes, they should not be used in electronics.

## Surface Preparation

In order for the solder to adhere to the connection, the metals must be clean and free of nonmetallic materials. Flux in the solder can remove oxides from metal but not other materials like dirt or grease. To remove these, use a small steel brush or fine emery cloth.

## Mechanical Connection

When all the surfaces are clean, the metals should have a solid mechanical connection. Wires should be tightly wrapped around each other or to the terminal. This will eliminate large gaps that create weak solder joints. Solder should not be used as a mechanical connection.

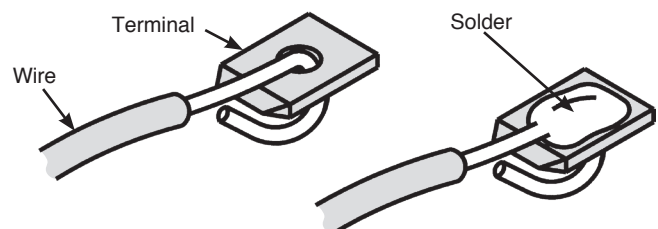


Figure 2

## Types of Soldering Devices

A number of different types of soldering devices: irons, guns and stations are available today. Irons are used for light to medium work and guns are for medium to heavy-duty work. The station type can range from light to heavy-duty. For working on PC boards, irons ranging from 15 to 40 watts are suitable, or a station with a range of 15 to 40 watts. If you use an iron with a higher wattage rating than 40 watt, you may damage the copper tracks on the PC board. The higher wattage irons are best suited for heavy-duty electrical jobs.



## Solder Tips

The tip is the very important part of the iron. The material that the tip is made from is an essential factor. The soldering iron tip contains four different metals as shown in Figure 3. The core consists of copper because of its high thermal conductivity. Since the copper is a soft material, it is plated with iron to maintain the shape. Chrome plating is used on the area where no soldering takes place to prevent oxidation. Then the tip is plated with tin, because it can be easily cleaned.

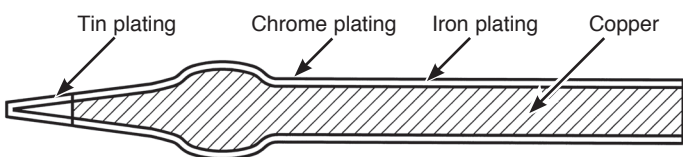
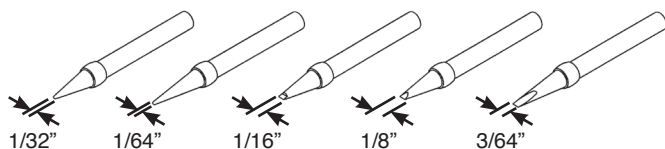


Figure 3

Today, tips are manufactured in a variety of different shapes (see figure below). The chisel shape is one of the most common. Having a choice of tip styles allows you to choose the one best suited for your soldering needs. Due to the high heat, removable tips can bond themselves to the heating element if left in place for extended periods of time. Periodic removal of the tip is therefore advisable.



## Tip Cleaning

A good clean solder tip makes soldering much easier. The tip should be tinned by lightly coating it with solder to prevent it from oxidizing. The tip can become pitted (black spots) from normal use. It is important to clean the tip by wiping it with a wet sponge or rag. For tips that need a good cleaning, the tip tinner and cleaner should be used. **Never use a file or abrasive material to clean the tip.** Using such methods will damage the plating and ruin the tip. Do not remove the excess solder from the tip before storing. The excess solder will prevent oxidation.

## Clean Connections

Proper solder adhesion requires that the metal surface to be free of dirt and grease. The flux only removes the oxides so a brush or rag can be used to clean metal. There are contact cleaners in aerosol cans and other solvents available.

## Desoldering

Great care should be taken when repairing or correcting a mistake on a PC board. The metal foil can be easily pulled up or broken from excessive heat. Use the least amount of heat as possible. You can use a desoldering tool, bulb, wick or a station. These tools will remove the solder enabling you to correct the problem.



# SOLDER PRACTICE

## Double Pads

Before we begin to assemble and solder the components to the solder practice PC board, we will start first by practice soldering to the double pads on the edge of the PC board (see Figure 3).



Figure 3

1. Apply a small amount of solder to the iron tip. This allows the heat to leave the iron and onto the foil.
2. Place the iron on the top half of pad and then apply the solder (see Figure 4). Allow the solder to flow around the pad. Then, remove the solder and the iron and let the solder cool. The solder should be neat and smooth.
3. Repeat step 2 on the top row of the pads (see Fig. 4).

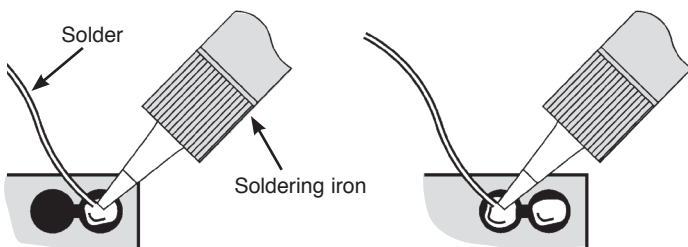
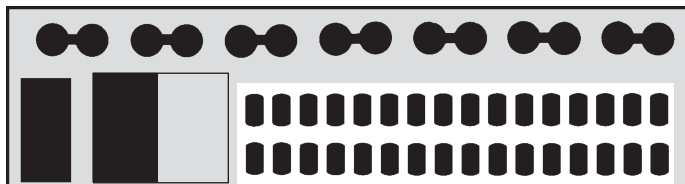


Figure 4

## Single Pads

Now practice using the single pads. Use the same soldering procedures as the large double pads. Be sure there are no solder bridges between the pads. (Refer to the Solder Bridge Section below).



## Solder Bridge

Solder bridges occur when solder runs between circuit paths and creates a short circuit. This is usually caused by using too much solder. Using the top row of single pads, try intentionally to make a solder bridge on each section (see Figure 5). Then, remove it by simply dragging your soldering iron across the solder bridge as shown. It is best to wipe the iron tip with a wet sponge to remove the solder. You can also use solder wick as described on page 8.

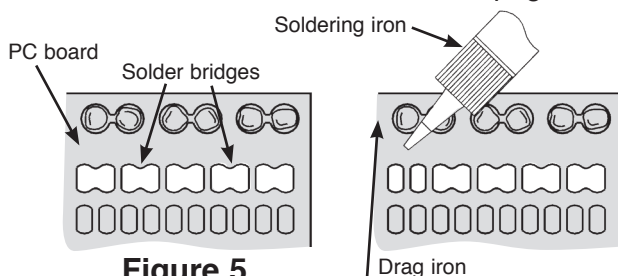


Figure 5

## Solder Resist

The PC board is covered with solder resist over areas that are not to be soldered. This is done to reduce soldering shorts to adjacent metal runs. On the large pad, note that half of the pad is covered with solder resist. Try soldering to the covered pad. You will find that it is impossible to solder.

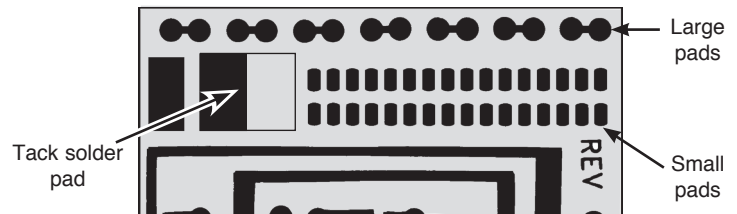


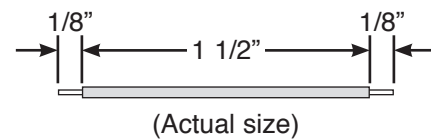
Figure 6 Practice Solder Area

**Note:** There are three pieces of wire included. Save one piece for the speaker assembly.

## Tack Soldering

You will make 14 tack solder connections by soldering seven wires to the top row of pads.

1. Cut seven 1 1/2" wires and strip 1/8" insulation off both ends (see figure below).



2. Place the iron and the wire on top right pad as shown in Figure 7. Allow the solder to flow around the wire. Then, remove the iron and let the solder cool. You may need to add some more solder. The solder should be neat and smooth.
3. Pull the wire to make sure you have a good solder joint.
4. Bend the wire and solder it to the next pad, as shown in Figure 7.
5. Now solder the remaining wires to the pads as shown in Figure 7.

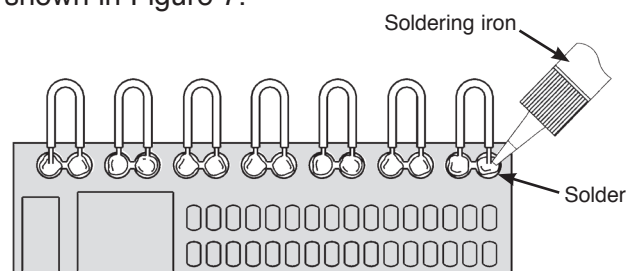


Figure 7

## PC BOARD REPAIR

### Hairline Cracks

The hairline cracks can develop in the copper foil if the PC board is flexed. This can be easily repaired by making a solder bridge across the two foils. The solder should smoothly flow across the foil as shown in Figure 8. If the solder does not adhere to the foil, it will sit on the foil as a blob as shown in Figure 9.

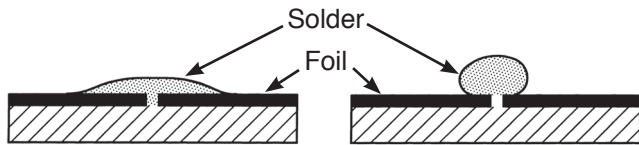


Figure 8

Figure 9

1. Make five solder bridges using the second row of single pads, starting from the left side (see Figure 10).

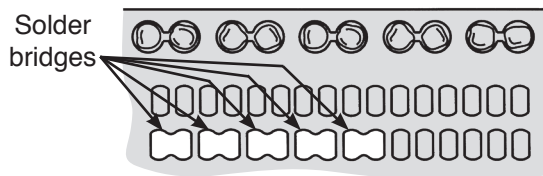


Figure 10

### Reinforcing a Repair

A solder bridge repair can be reinforced using a solid wire. Now add a wire to the five solder bridges you just made.

1. Strip a 1/2" of insulation off one end of the wire and then tin it.
2. Hold the tinned wire on top of the solder bridge.
3. Place the iron on the wire until the solder melts.
4. Remove the iron while holding the wire in place against the foil. Make sure the wire does not move until the solder hardens.
5. Check for a good solder connection.
6. Cut the wire off as close to the solder joint as possible.
7. Practice this procedure four more times.

### Wide Gaps

For wider gaps in a copper foil, a solder bridge can not be used. A small wire would be used to bridge the copper as shown in Figure 11. Six bridges will be made across the two rows of small pads.

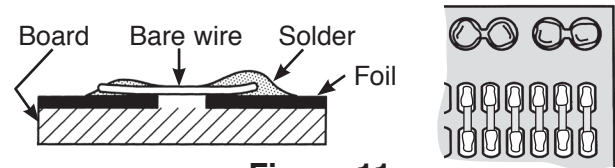


Figure 11

1. Place the iron on the top half of pad and then apply the solder. Allow the solder to flow around the pad. Then, remove the solder and the iron and let the solder cool. The solder should be neat and smooth.
2. Repeat Step 1 on the lower pad.
3. Strip 1/2" of insulation off one end of the wire and then tin it.
4. Hold the wire on the top pad and then place the iron on the wire. The solder will melt and the wire will press down against the pad (see Figure 11). Remove the iron while holding the wire in place against the foil. Make sure the wire does not move until the solder hardens.
5. Check for a good solder connection.
6. Solder the wire to the lower pad.
7. Cut the wire off as close to the solder joint as possible (see Figure 11).
8. You can hold the wire down with a screwdriver and resolder the wire.
9. Practice this procedure four more times on remaining pads.



## REMOVING EXCESS SOLDER USING SOLDER WICK

Desoldering wick is a braided wire coated with non-corrosive rosin flux. It is the simplest and safest tool for removing solder from a solder connection. When the braided wire is heated, the flux cleans and breaks up the surface tension so the melted solder from the

connection flows into the braid by capillary action.

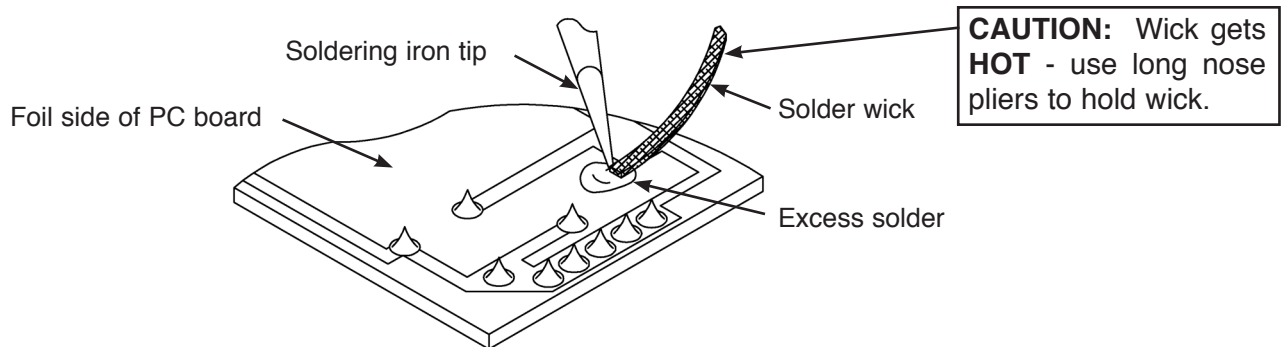
Included in this kit is a six inch length of solder wick (desoldering braid).

### Using the Solder Wick

- ❑ Place the solder wick on one of the pads and the iron on top of it (see Figure 12).
- ❑ As the solder melts, it will be drawn into the wick.
- ❑ When the iron and wick are removed, the solder should be removed. You need to repeat the process if some solder remains.

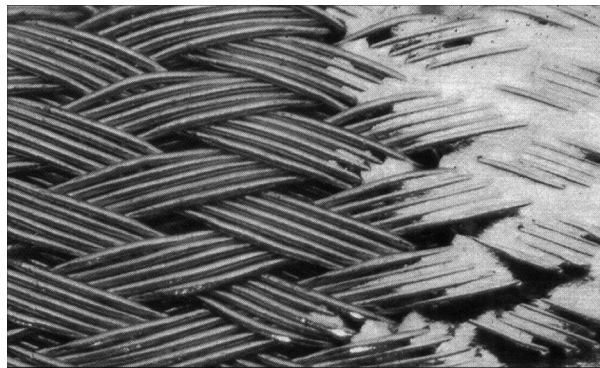
If necessary, repeat the procedure until all of the unwanted solder is removed.

After the excess solder has been wicked away by the desoldering braid, clip off and discard the solder-saturated portion of the braid. For best results, always use a fresh area of the braid for each procedure.



Using solder wick to remove excess solder.

Figure 12



A close-up view of the accumulation of solder onto the solder wick (desoldering braid).

Figure 13

## THEORY OF OPERATION

The solder practice kit consists of a circuit oscillating at one hertz (one cycle per second). The oscillator consists of two transistors Q1 and Q2, and resistors, R1-R11 and capacitors C1 and C2. This configuration is known as a multivibrator circuit.

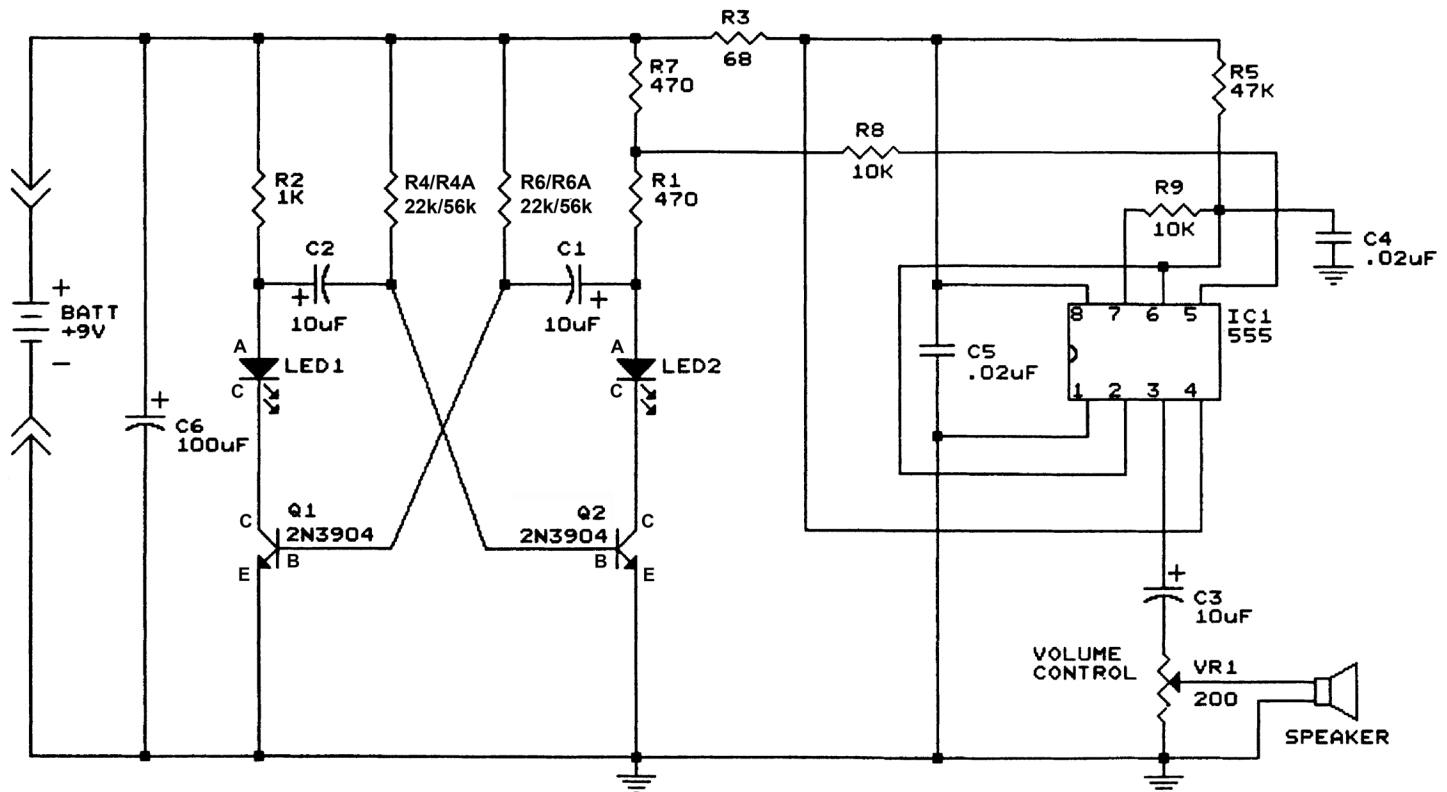
The solder practice kit produces the sound of the European siren. It consists of two oscillators, a one hertz (one cycle per second) and a 1500Hz. The one hertz oscillator consists of two transistors Q1 and Q2, and resistors R1, R2, R6 and R7 capacitors C1 and C2. This configuration is known as a multivibrator circuit.

When voltage is first applied to this multivibrator circuit, one transistor (possibly Q1) will conduct faster, causing transistor Q2 to stay off. Q1 will continue to conduct until it saturates. At this point, Q2 will start to conduct, causing Q1 to rapidly cutoff. This process continues alternately causing Q1 or Q2 to conduct. The output will be a square wave.

The frequency is determined by the time constants of resistor R6 and capacitor C1, also R4 and C2. Two LED diodes are placed in the collectors of the transistors. The LEDs will light when current is passing through them. Resistors R2, R1 and R7 determine the current passing through the LEDs.

Integrated circuit IC1 is the heart of the second oscillator. A 555 timer IC is used in the circuit. This IC contains many transistors and resistors on a silicon chip and thus eliminates many external parts. The frequency of this oscillator is determined by resistors R5, R9 and capacitor C4. Capacitor C3 couples the output of operations of IC1 via resistor R8. This changes the operations of IC1 during one half cycle of the multivibrator causing the frequency to change from 1500Hz to 2200Hz. This results in a speaker output that varies constantly in pitch. The multivibrator circuit not only causes the LED to flash, but also varies the pitch at the speaker output.

## SCHEMATIC DIAGRAM



NOTE: RESISTORS ARE IN OHM  
CAPACITORS ARE IN MICROFARAD

SOLDER PRACTICE KIT  
REV E

# CONSTRUCTION

## Introduction

The most important factor in assembling your SP-1A / AK-100 Solder Practice Kit is good soldering techniques. Using the proper soldering iron is of prime importance. A small pencil type soldering iron of 25 watts is recommended. **The tip of the iron must be kept clean at all times and well-tinned.**

## Solder

For many years leaded solder was the most common type of solder used by the electronics industry, but it is now being replaced by lead-free solder for health reasons. This kit contains lead-free solder, which contains 99.3% tin, 0.7% copper, and has a rosin-flux core.


Lead-free solder is different from lead solder: It has a higher melting point than lead solder, so you need higher temperature for the solder to flow properly. Recommended tip temperature is approximately 700°F; higher temperatures improve solder flow but accelerate tip decay. An increase in soldering time may be required to achieve good results. Soldering iron tips wear out faster since lead-free solders are more corrosive and the higher soldering temperatures accelerate corrosion, so proper tip care is important. The solder joint finish will look slightly duller with lead-free solders.

Use these procedures to increase the life of your soldering iron tip when using lead-free solder:

- Keep the iron tinned at all times.
- Use the correct tip size for best heat transfer. The conical tip is the most commonly used.

- Turn off iron when not in use or reduce temperature setting when using a soldering station.
- Tips should be cleaned frequently to remove oxidation before it becomes impossible to remove. Use Dry Tip Cleaner (Elenco® #SH-1025) or Tip Cleaner (Elenco® #TTC1). If you use a sponge to clean your tip, then use distilled water (tap water has impurities that accelerate corrosion).

## Safety Procedures

- **Always wear safety glasses or safety goggles to protect your eyes when working with tools or soldering iron, and during all phases of testing.** 
- Be sure there is **adequate ventilation** when soldering.
- Locate soldering iron in an area where you do not have to go around it or reach over it. Keep it in a safe area away from the reach of children.
- **Do not hold solder in your mouth.** Solder is a toxic substance. Wash hands thoroughly after handling solder.

## Assemble Components

In all of the following assembly steps, the components must be installed on the top side of the PC board unless otherwise indicated. The top legend shows where each component goes. The leads pass through the corresponding holes in the board and are soldered on the foil side.

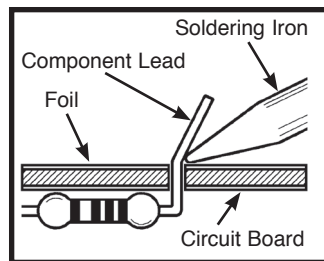
**Use only rosin core solder.**

**DO NOT USE ACID CORE SOLDER!**

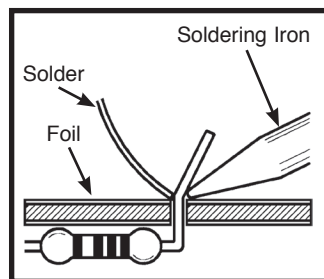
## What Good Soldering Looks Like

A good solder connection should be bright, shiny, smooth, and uniformly flowed over all surfaces.

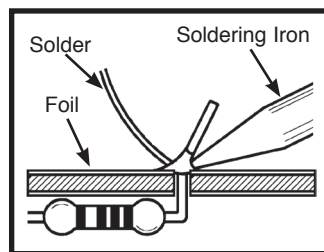
1. Solder all components from the copper foil side only. Push the soldering iron tip against both the lead and the circuit board foil.



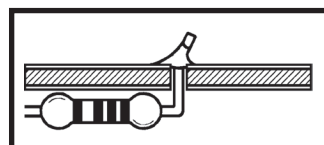
2. Apply a small amount of solder to the iron tip. This allows the heat to leave the iron and onto the foil. Immediately apply solder to the opposite side of the connection, away from the iron. Allow the heated component and the circuit foil to melt the solder.



3. Allow the solder to flow around the connection. Then, remove the solder and the iron and let the connection cool. The solder should have flowed smoothly and not lump around the wire lead.

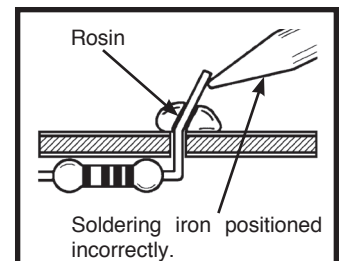


4. Here is what a good solder connection looks like.

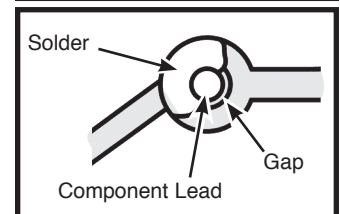


## Types of Poor Soldering Connections

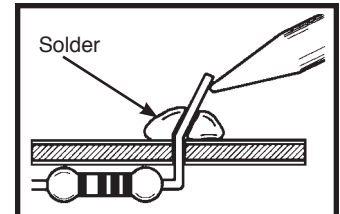
1. **Insufficient heat** - the solder will not flow onto the lead as shown.



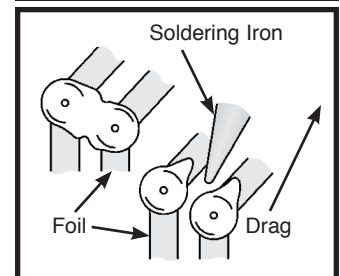
2. **Insufficient solder** - let the solder flow over the connection until it is covered. Use just enough solder to cover the connection.



3. **Excessive solder** - could make connections that you did not intend to between adjacent foil areas or terminals.



4. **Solder bridges** - occur when solder runs between circuit paths and creates a short circuit. This is usually caused by using too much solder. To correct this, simply drag your soldering iron across the solder bridge as shown.

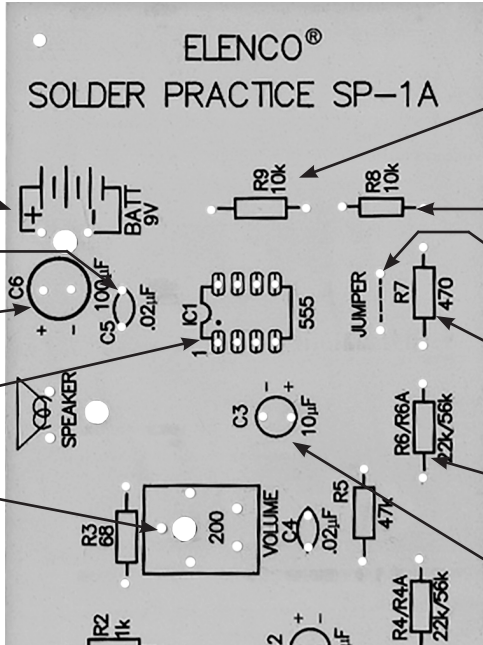


# PC BOARD ASSEMBLY

**NOTE:** Before beginning assembly, please refer to page 13 for the resistor reading exercise. This will familiarize you with the resistor color band coding.

Solder the following parts to the PC board.

- Battery Snap (see Figure A)
- C5 - 0.02 $\mu$ F or 0.022 $\mu$ F Discap
- C6 - 100 $\mu$ F Electrolytic (Lytic) (see Figure B)
- IC1 - 555 or 1455 Timer (see Figure C)
- VR1 - 200 $\Omega$  Potentiometer (see Figure D)

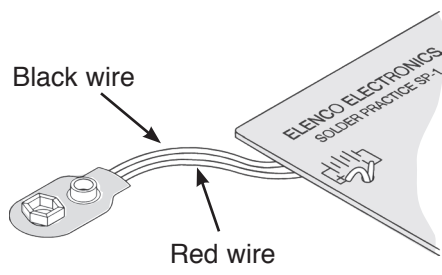


ELENCO®  
SOLDER PRACTICE SP-1A

- R9 - 10k $\Omega$  5% 1/4W Resistor (brown-black-orange-gold) (see Figure E)
- R8 - 10k $\Omega$  5% 1/4W Resistor (brown-black-orange-gold) (see Figure E)
- Jumper Wire (see Figure F)
- R7 - 470 $\Omega$  5% 1/4W Resistor (yellow-violet-brown-gold) (see Figure E)
- R6 - 22k $\Omega$  5% 1/4W Resistor (red-red-orange-gold) (see Figure E)
- C3 - 10 $\mu$ F Electrolytic (Lytic) (see Figure B)

**Figure A**

Solder the Red Positive (+) lead of the battery snap to the hole marked (+) on the PC board. Solder the Black Negative (-) lead to the hole marked (-) on the PC board. Cut off the excess leads.



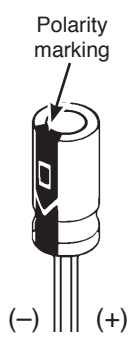
Black wire

Red wire

**Figure B**

Electrolytic capacitors have polarity. Be sure to mount them with the negative (-) lead (marked on side) in the correct hole.

**Warning:** If the capacitor is connected with incorrect polarity, it may heat up and either leak or cause the capacitor to explode.

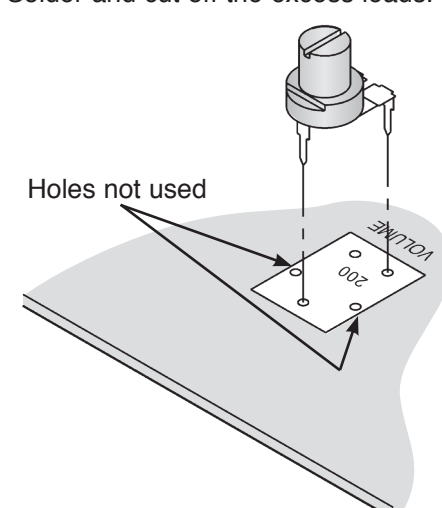


Polarity marking

(-) (+)

**Figure D**

Mount VR1 into the three holes in the PC board as shown below. Note that the other two holes are not used. Solder and cut off the excess leads.

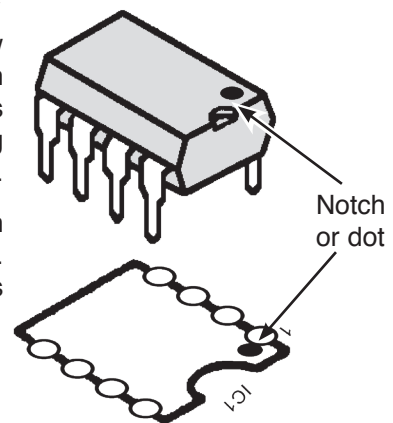


Holes not used

**Figure C**

Mount IC1 in the location shown below onto the PC board. Be sure that the notch or dot on the IC is in the same direction as the marking on the PC board (see drawing below). Solder and cut off the excess leads.

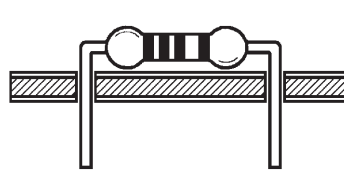
**NOTE:** Do not keep the soldering iron on the IC leads for extended periods of time. You run the risk of overheating the IC, thus damaging it.



Notch or dot

**Figure E**

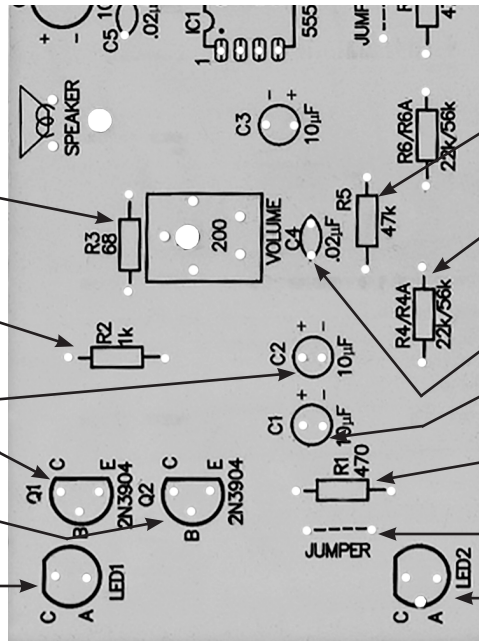
Mount the resistor flat against the PC board as shown.



# PC BOARD ASSEMBLY (continued)

Solder the following parts to the PC board.

- R3 - 68Ω 5% ¼W Resistor (blue-gray-black-gold) (see Figure E)
- R2 - 1kΩ 5% ½W Resistor (brown-black-red-gold) (see Figure E)
- C2 - 10μF Electrolytic (Lytic) (see Figure B)
- Q1 - 2N3904 Transistor
- Q2 - 2N3904 Transistor (see Figure G)
- LED1 - Light Emitting Diode (see Figure H)



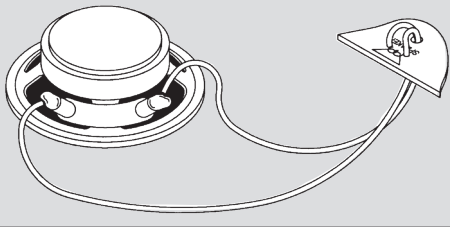
- R5 - 47kΩ 5% ¼W Resistor (yellow-violet-orange-gold) (see Figure E)
- R4 - 22kΩ 5% ¼W Resistor (red-red-orange-gold) (see Figure E)
- C4 - 0.02μF or 0.022μF Discap
- C1 - 10μF Electrolytic (Lytic) (see Figure B)
- R1 - 470Ω 5% ¼W Resistor (yellow-violet-brown-gold) (see Figure E)
- Jumper Wire (see Figure F)
- LED2 - Light Emitting Diode (see Figure H)

**Figure F**

Cut a 1" wire and strip 1/8" of insulation off of both ends.

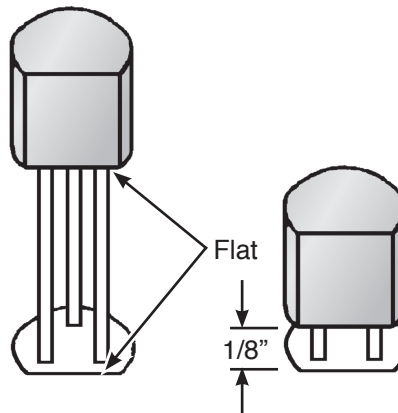


Cut two 6" wires and strip 1/8" of insulation off of both ends. Insert the speaker wire through the PC board as shown. Then, insert the wires into the speaker holes and solder. Solder the other end of the wires to the speaker.

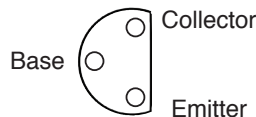


**Figure G**

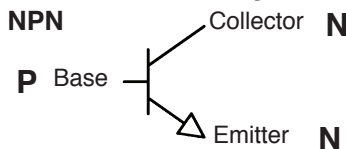
Mount the transistor with the flat side in the same direction as marked on the PC board. Leave about 1/8" of space between the transistor and the PC board as shown below. Solder and cut off the excess leads.



**Printed Circuit Board**



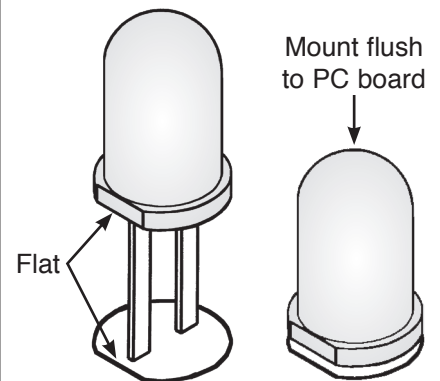
**Schematic Symbol**



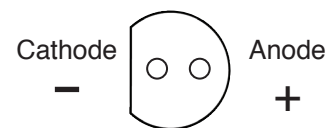
**Figure H**

Mount the LED onto the PC board with the flat side of the LED in the same direction as marked on the PC board. Be sure to mount the LED flush with the PC board as shown below.

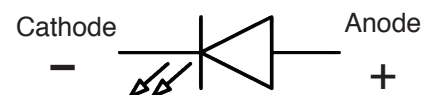
Solder and cut off the excess leads.



**Printed Circuit Board**



**Schematic Symbol**



---

## OPERATION

After completing the assembly of the kit, double back to see that the soldering looks good and all of the components are in their proper place. If everything is all right, attach the 9V battery to the battery snap. The LEDs should alternately light and the speaker should sound a wobbling siren.

**Continue to the Desoldering Practice/Component Replacement Section.**

**Note:** Refer to the Troubleshooting Section if your circuit does not work.

---

## DESOLDERING PRACTICE/COMPONENT REPLACEMENT

In this exercise you will replace the 22k $\Omega$  resistors R4 and R6 with two 56k $\Omega$  resistors. You unsolder the resistors using the solder wick and then install new resistors R4A and R6A.

1. Remove the battery from the battery snap.
2. Locate the pads that resistor R4 is soldered to.
3. Place the solder wick on one of the pads and the iron on top of it (refer to page 8).
4. As the solder melts, it will be drawn into the wick.

5. When the iron and wick are removed, the solder should be removed. You need to repeat the process if some solder remains.
6. Unsolder the other lead and remove, then remove the resistor.
7. Follow the same procedure and remove resistor R6.

Now use the resistors R4A and R6A mounted on the component card, and install them on the PC board. Reconnect the battery and the kit should oscillate at the correct frequency.

---

## TROUBLESHOOTING

If any parts are missing or damaged, see instructor or bookstore. **DO NOT** contact your place of purchase as they will not be able to help you.

Contact ELENCO® (address/phone/e-mail is at the back of this manual).

If you are experiencing a problem, first read the theory of operation to familiarize yourself with the operation.

### Component Check

1. Be sure that all components have been mounted in their correct places.
2. Make sure that C1 and C2, the electrolytic capacitor is mounted correctly. The negative lead should be in the hole as shown on the top legend.
3. Have LEDs LED1 and LED2 been installed correctly? The flat side of their bodies should be in the same direction as marked on the top legend. If the LEDs are in backwards, they will not light.
4. Pay close attention to the red and black wires of the battery snap. The red wire should be installed in the positive (+) hole and the black wire in the negative (–) hole. Snap in a fresh 9-volt battery.

### Problems

#### 1. No LEDs Light

- Check the solder connections for the battery wires and switch.
- Check that all parts are in the correct way.

#### 2. LED1 Does Not Light

- Check C1, LED1 and Q1.

#### 3. LED2 Does Not Light

- Check C2, LED2 and Q2.

#### 4. LED1 or LED2 is Always On

- Check C1 and C2 for opens.
- Check Q1 and Q2 for shorts.

Remember that there are two oscillators. If no sound comes out of the speaker, but the LED flashes alternately, then the 555 timer is not working. Be sure that the volume control is at maximum. Check the components IC1, R5, R8, R9, C3, C4 and C5. Be sure that the IC is in properly.

If a steady sound (not wobbling) comes out of the speaker, then the multivibrator is not working. Check the components associated with transistor Q1 and Q2. Check the LED by shorting the transistor collector to the emitter. The LED should light. If not, then the LED is either open or backward.



## QUIZ

- The oscillator in this kit is known as a . . .
  - A. one-shot circuit.
  - B. multivibrator circuit.
  - C. three phase circuit.
  - D. tri-state circuit.
- What type of flux should be used in electronics?
  - A. Chloride
  - B. Organic
  - C. Rosin
  - D. Corrosive
- When working on PC boards, what wattage range of iron is ideal?
  - A. 15-40 watts
  - B. 50-100 watts
  - C. 1-10 watts
  - D. 100-200 watts
- Tinning the soldering tip will prevent it from . . .
  - A. heating.
  - B. melting.
  - C. soldering.
  - D. oxidizing.
- Proper solder adhesion requires that the metal surface to be . . .
  - A. solder free.
  - B. clean.
  - C. greasy.
  - D. cold.
- Solder wick is used to . . .
  - A. remove solder.
  - B. solder in small parts.
  - C. cleaning the soldering iron tip.
  - D. removing flux.
- A cold solder joint is caused by . . .
  - A. a solder bridge.
  - B. using 60/40 solder.
  - C. insufficient heat.
  - D. acid core solder.
- When two adjacent foils accidentally touch, it is called . . .
  - A. a jumper.
  - B. a blob.
  - C. a solder hole.
  - D. a solder bridge.
- What ratio has the greatest amount of tin?
  - A. 20/80
  - B. 40/60
  - C. 50/50
  - D. 60/40
- The frequency of the second oscillator ranges from . . .
  - A. 150-220Hz.
  - B. 15k-22kHz.
  - C. 15-22Hz.
  - D. 1500-2200Hz.

Answers: 1. B, 2. C, 3. A, 4. D, 5. B, 6. A, 7. C, 8. D, 9. D, 10. D



**ELENCO**<sup>®</sup>

150 Carpenter Ave.  
Wheeling, IL 60090  
[www.elenco.com](http://www.elenco.com)  
[support@elenco.com](mailto:support@elenco.com)



7 56619 00033 6