

# LINE TRACKING ROBOT

*LIGHTING SENSOR ROBOT KIT*

Assembly and Instruction Manual

# Contents



## **Line Tracking Robot:**

1. Product Introduction .....	P.1
2. Tools You May Need .....	P.1
3. Mechanical Parts List .....	P.1
4. Plastic Parts .....	P.3
5. Mechanical Assembly .....	P.3
<b>How it works</b> .....	P.10
<b>Trouble Shooting</b> .....	P.11
<b>Circuit Diagram</b> .....	P.11



# LINE TRACKING ROBOT

## 1 Product Introduction:

Line Tracking Robot will follow a black line on white ground by using 2 photo interrupters as its eyes.

The 2 photo interrupters will distinguish black and white by projecting infrared rays.

Power source:

Voltage / Electrical / Mechanical:

1.5 V " AA " x 2 (not included)

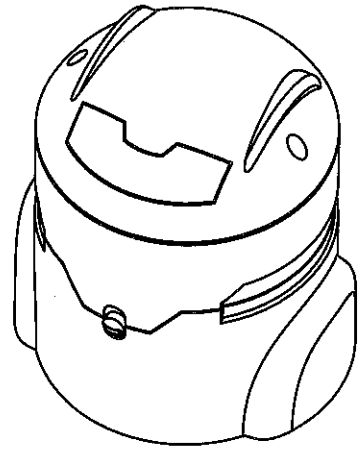

## 2 Tools You May Need:

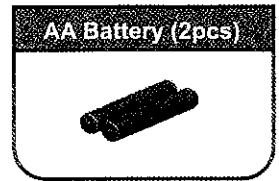
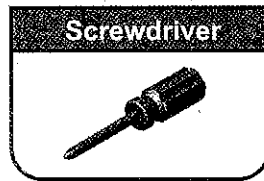
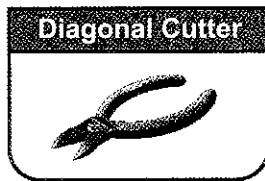
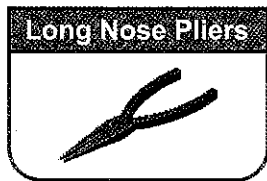

## 3 Mechanical Parts List:

P1	Motor	Qty
		1

P2	Motor	Qty
		1

P3	Pinion Gear 10T	Qty
		2

P4	Face Gear 36T/14T	Qty
		2 (White)

P5	Gear 36T/14T	Qty
		2 (Green)

P6	Gear 36T/14T	Qty
		2 (Red)

P7	Round Shaft With Gear 36T/0T	Qty
		2 (White)

P8	Post	Qty
		2

P9	Round Shaft	Qty
		1 (2x40)

<b>P10</b>	<b>Eyelet</b>	Qty
		4

<b>P11</b>	<b>Tapping Screw</b>	Qty
		8 (2.6x14)

<b>P12</b>	<b>Tapping Screw With Washer</b>	Qty
		2 (2.6x6)

<b>P13</b>	<b>Tapping Screw</b>	Qty
		9 (2.3x7)

<b>P14</b>	<b>Tapping Screw</b>	Qty
		1 (2.6x7)

<b>P15</b>	<b>Wheel</b>	Qty
		2

<b>P16</b>	<b>Tire</b>	Qty
		2

<b>P17</b>	<b>Steel Ball</b>	Qty
		1

<b>P18</b>	<b>Battery Holder</b>	Qty
		1

**P19** **Finished PCB**

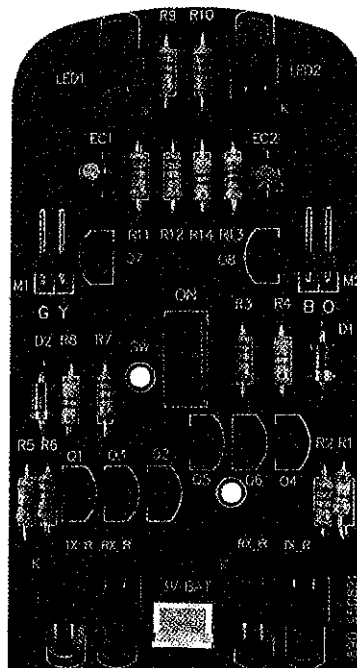

# 4 Plastic Parts:

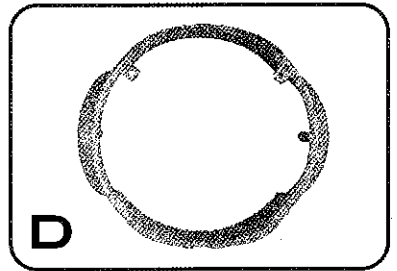
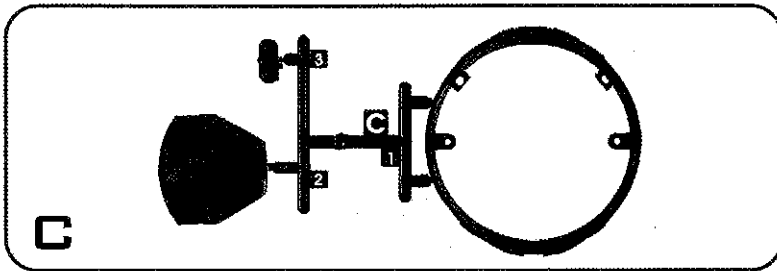
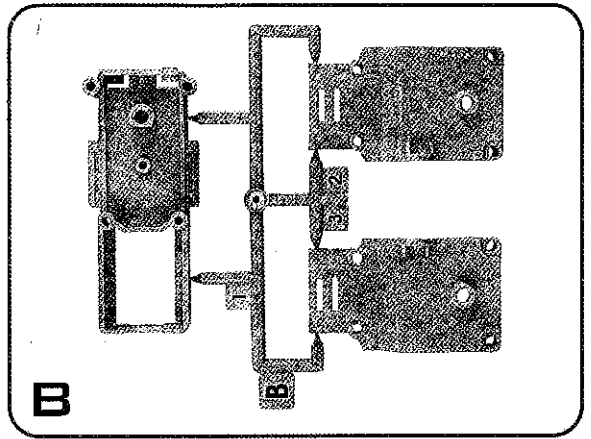
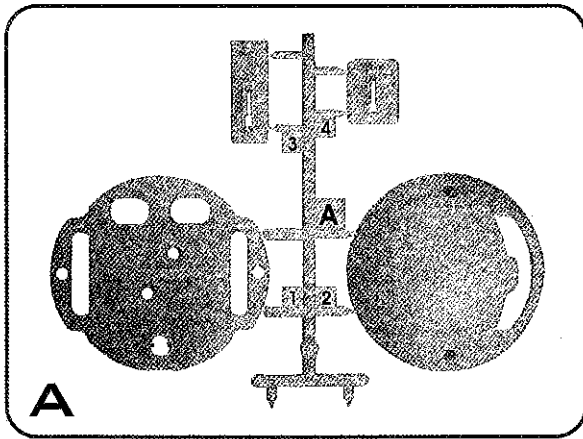

# 5 Mechanical Assembly:

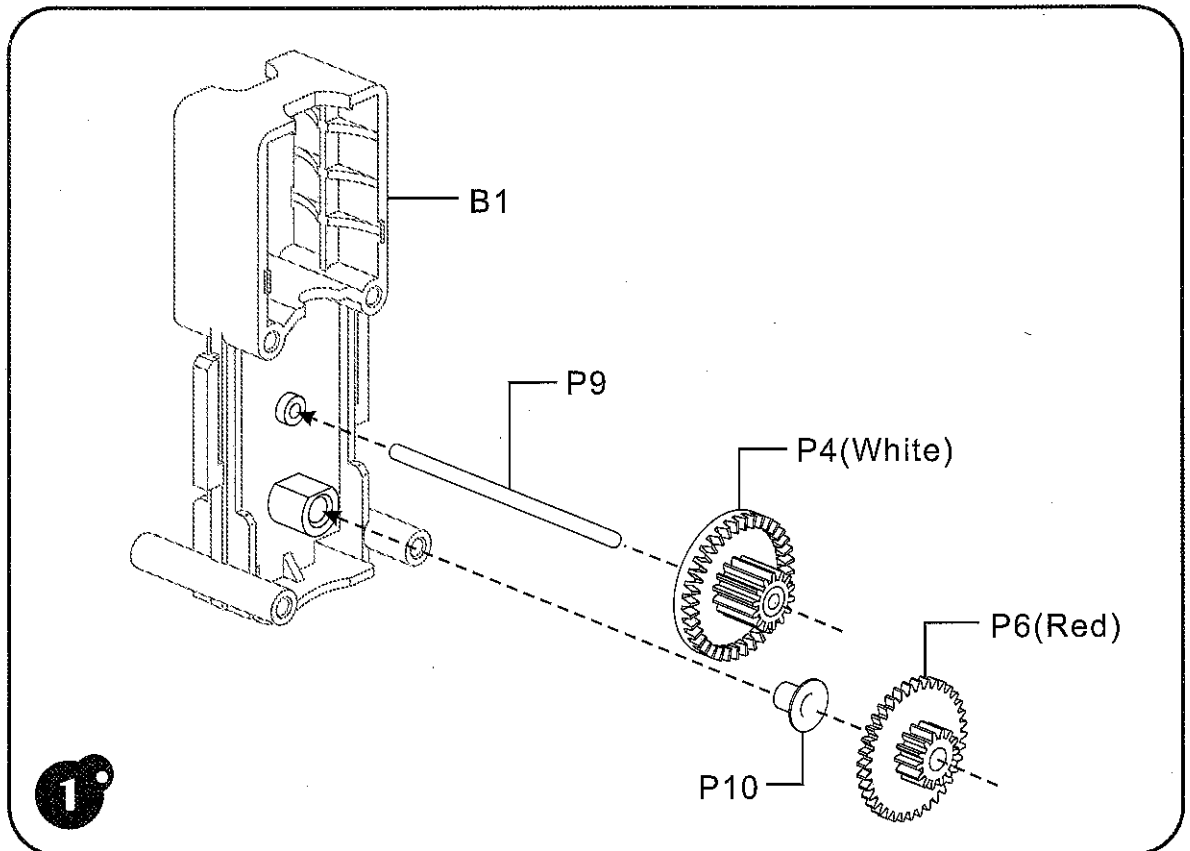

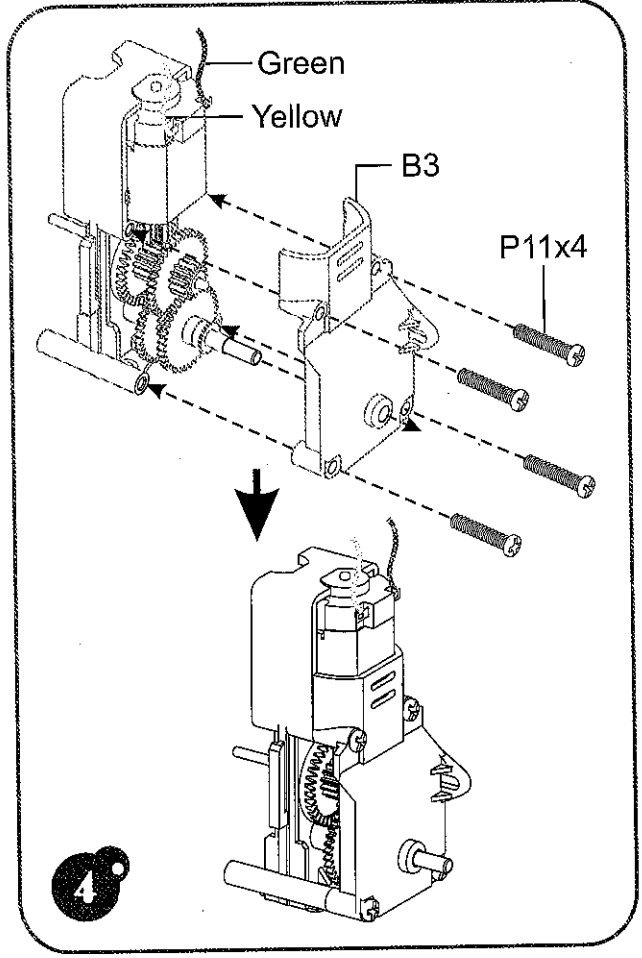
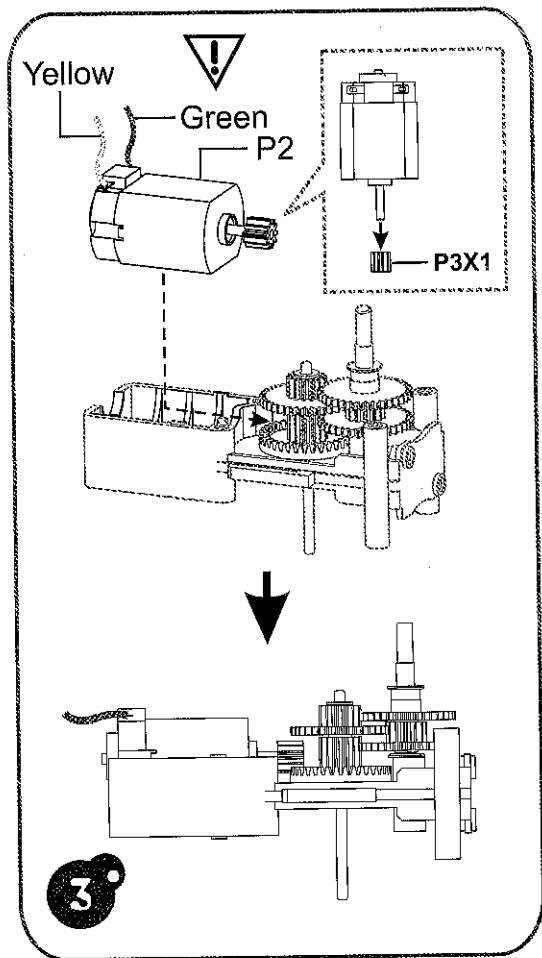
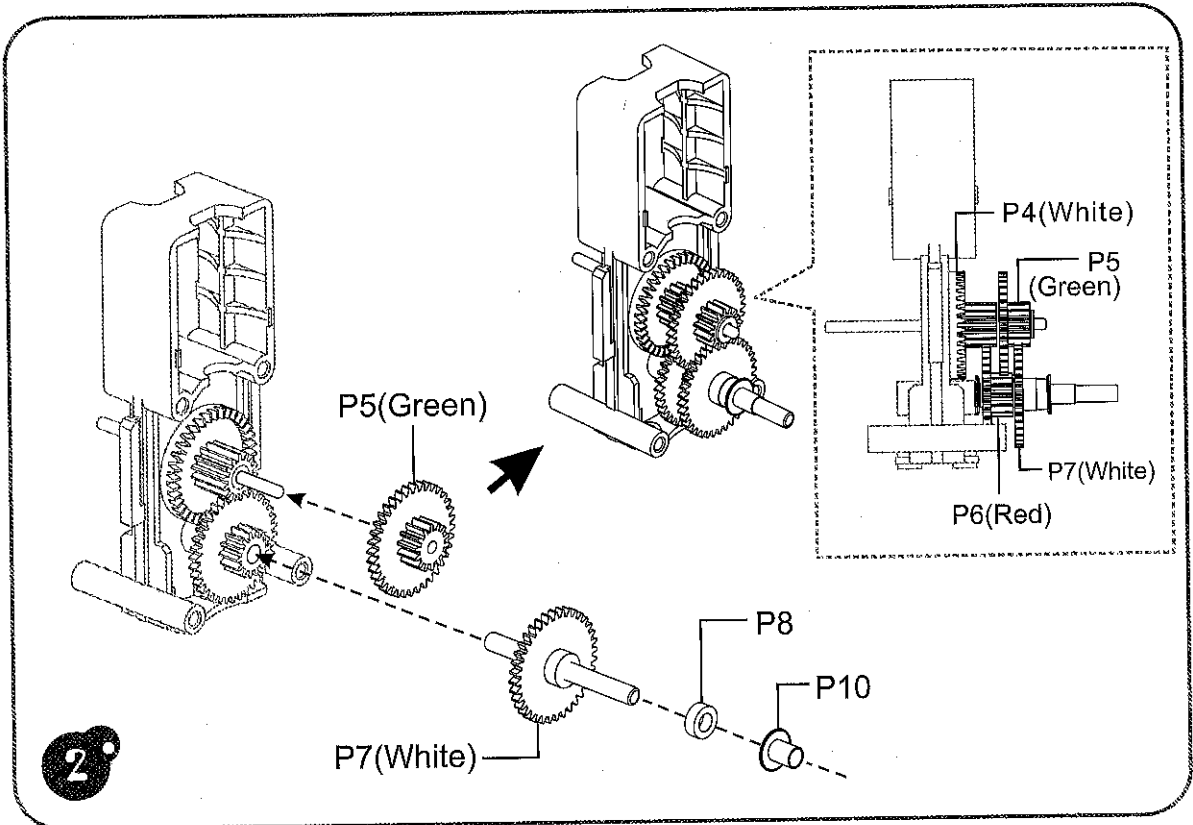

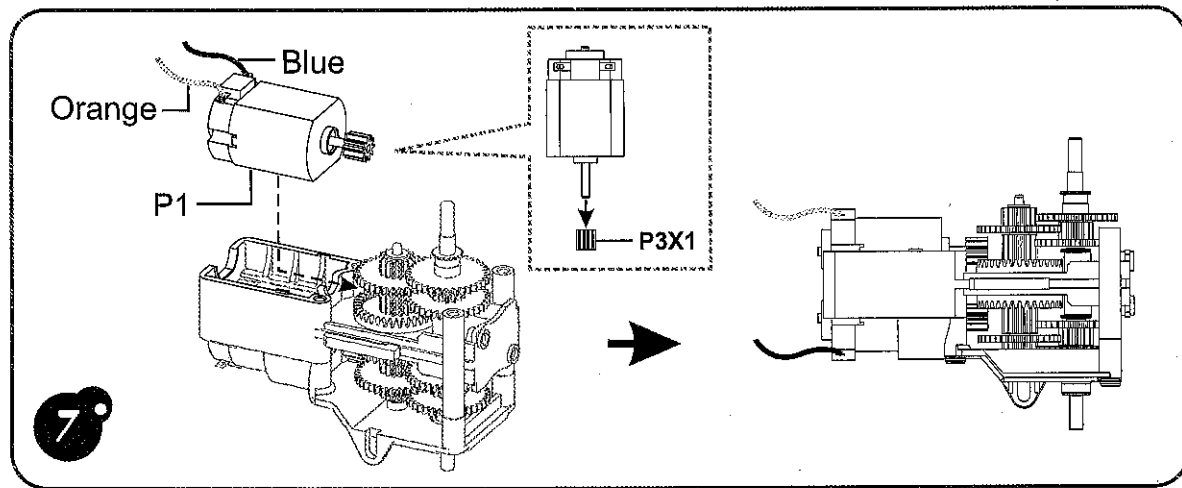
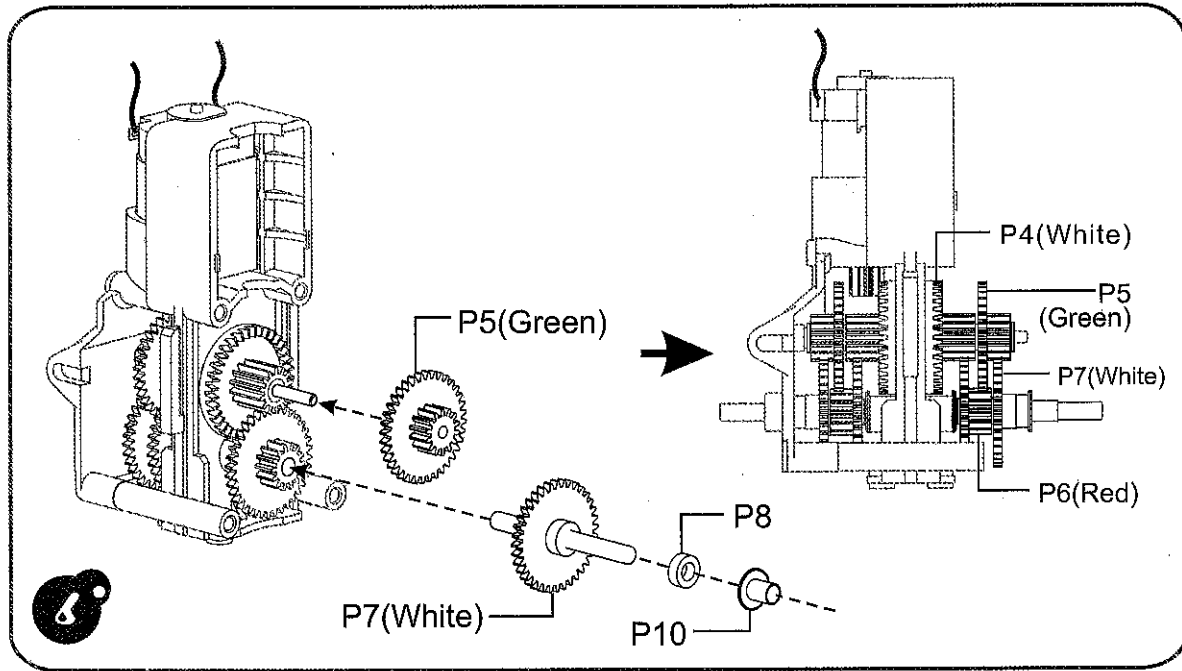
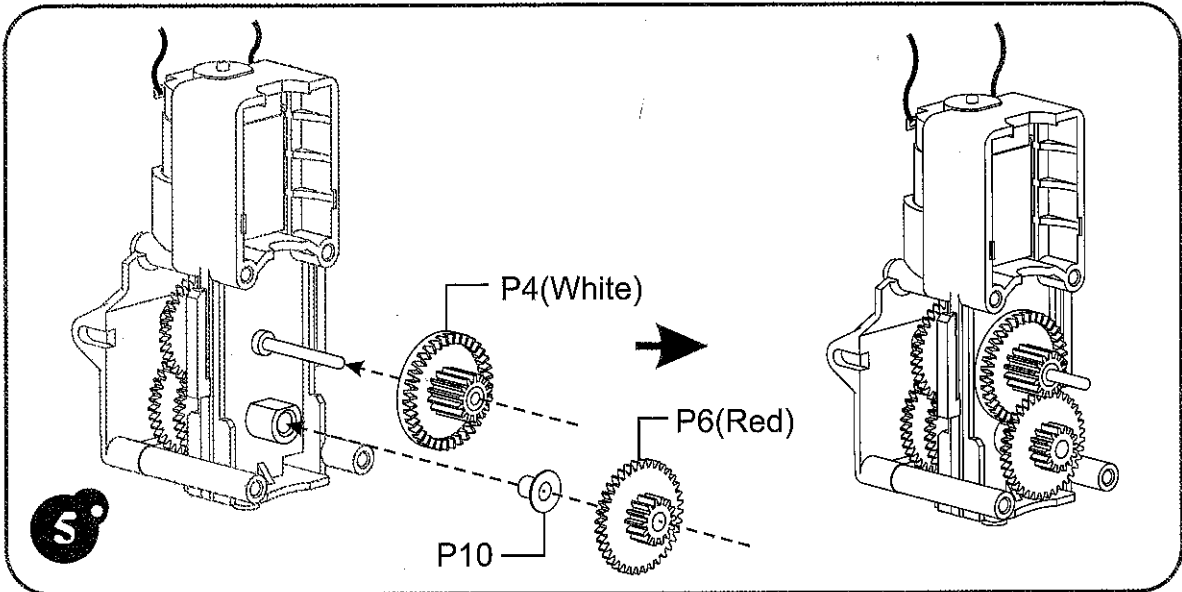

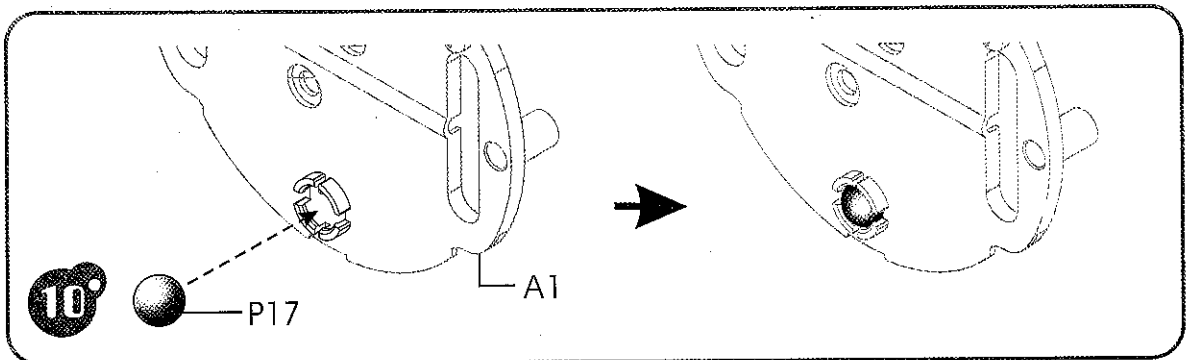
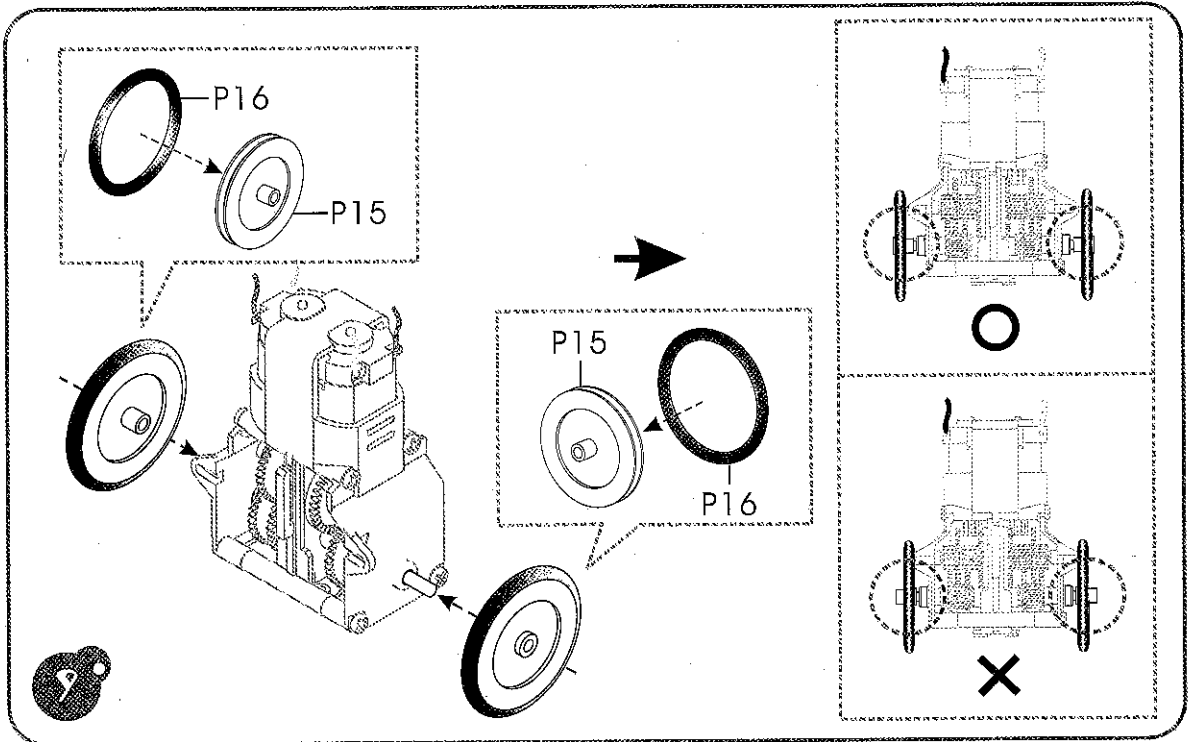
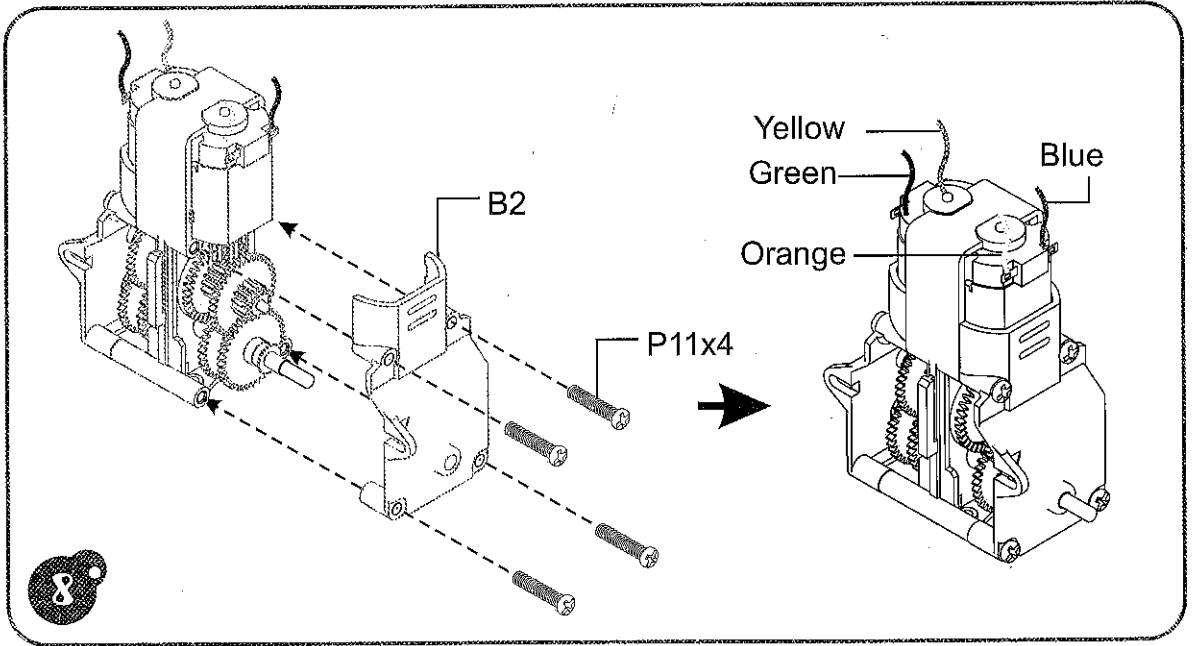



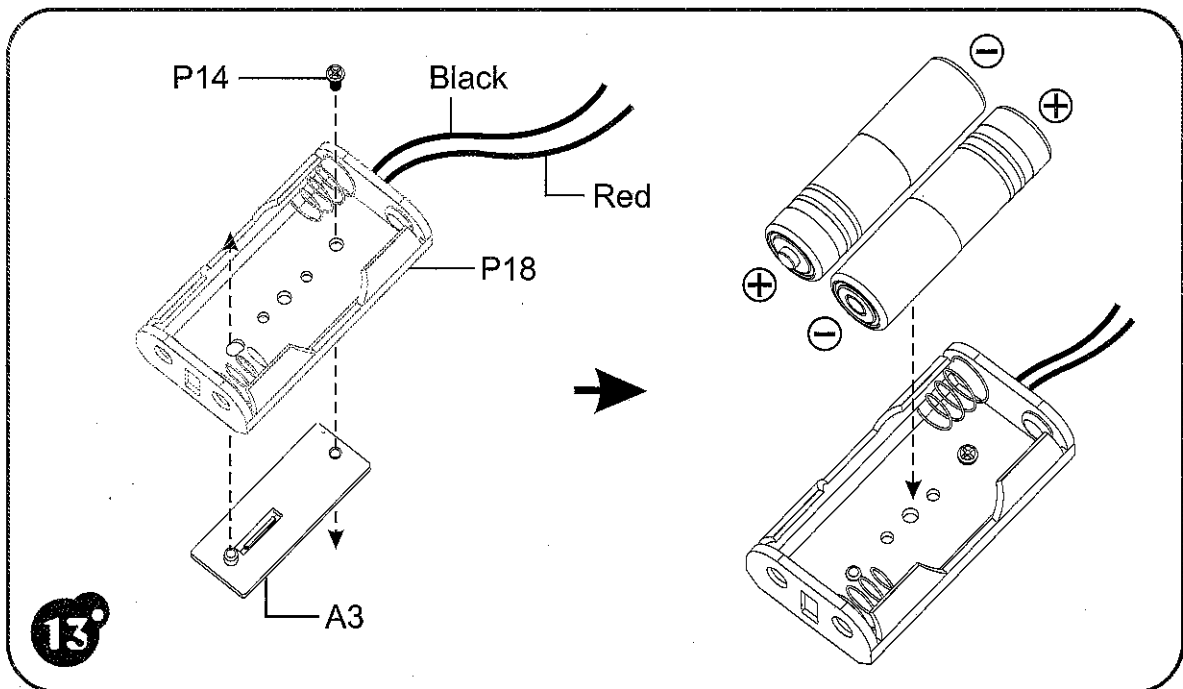
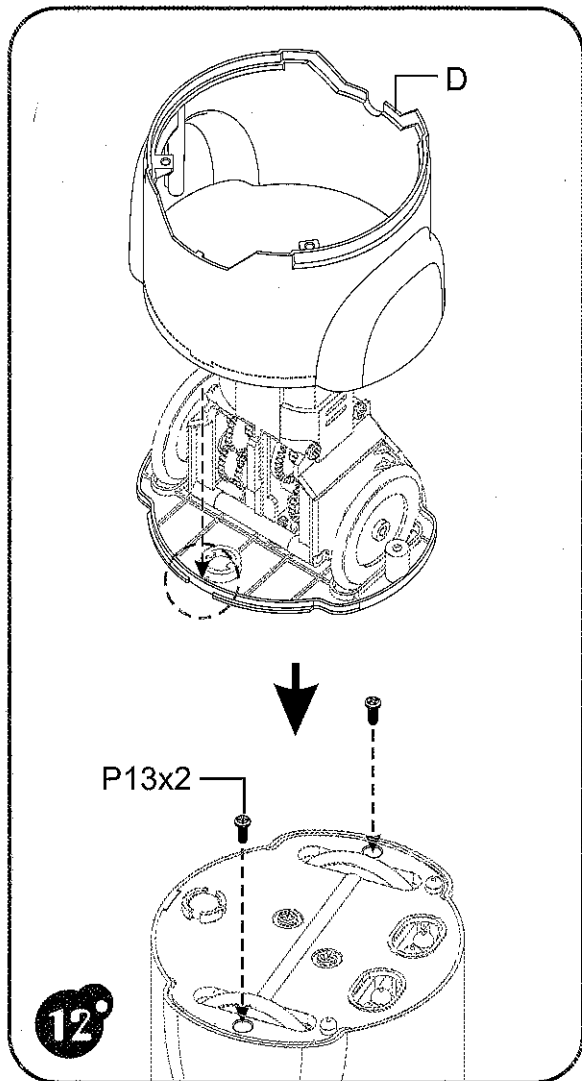
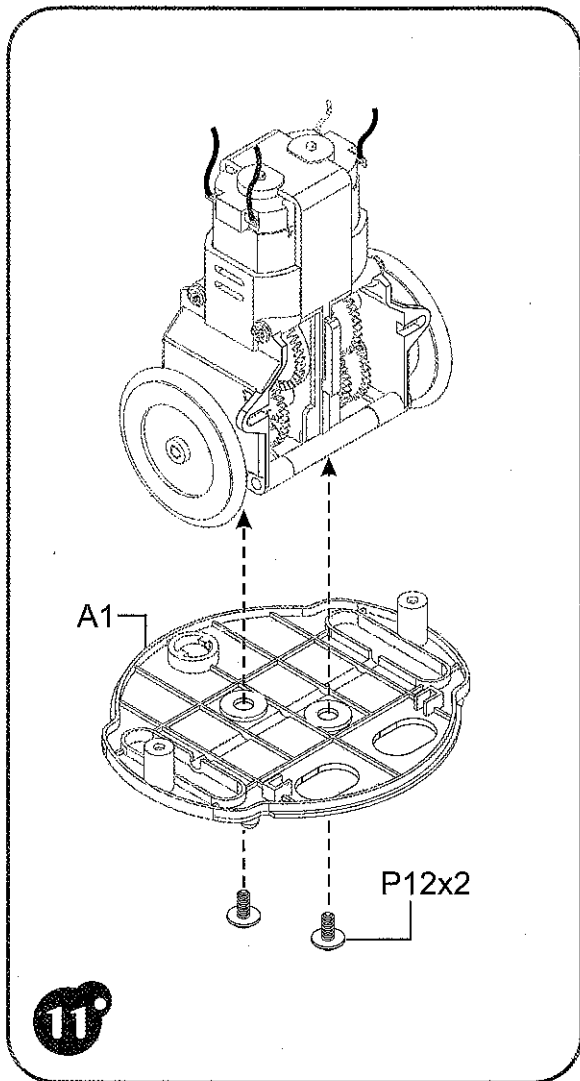

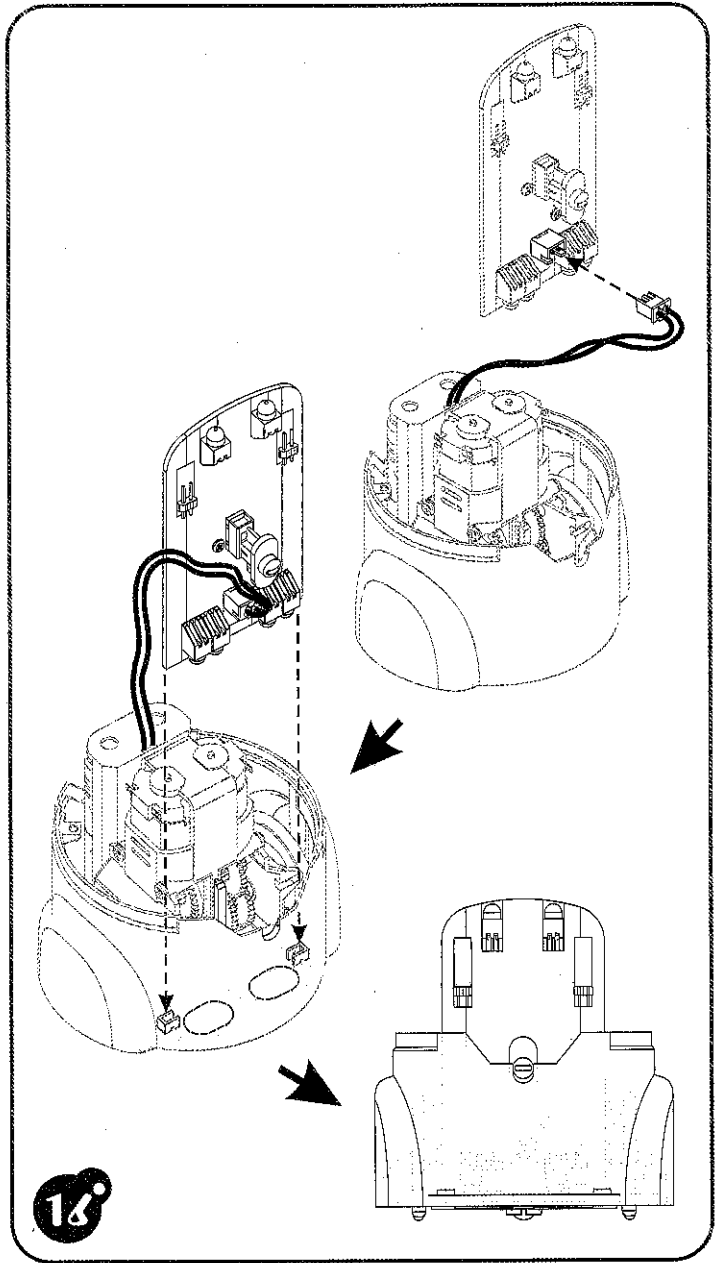
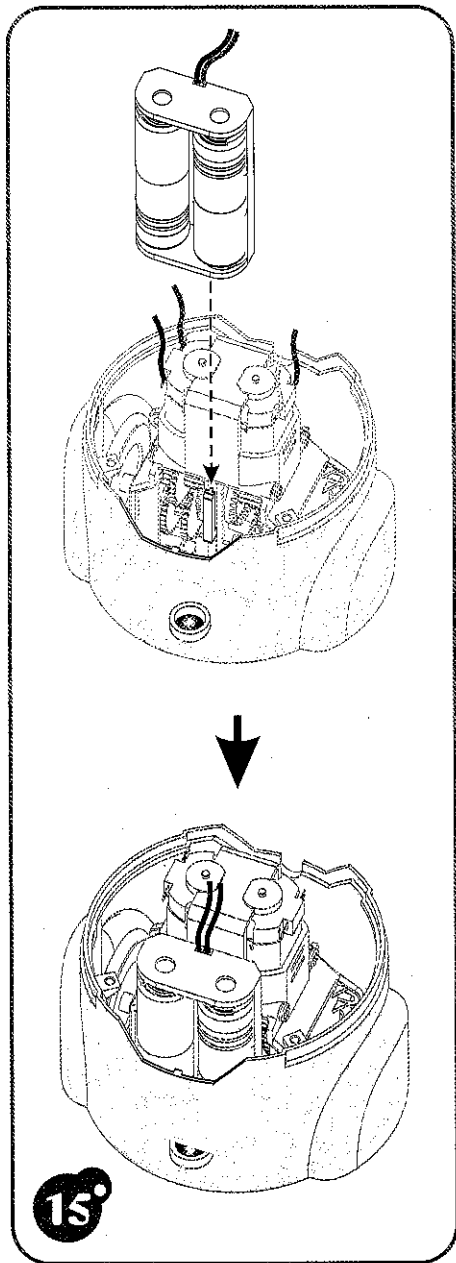
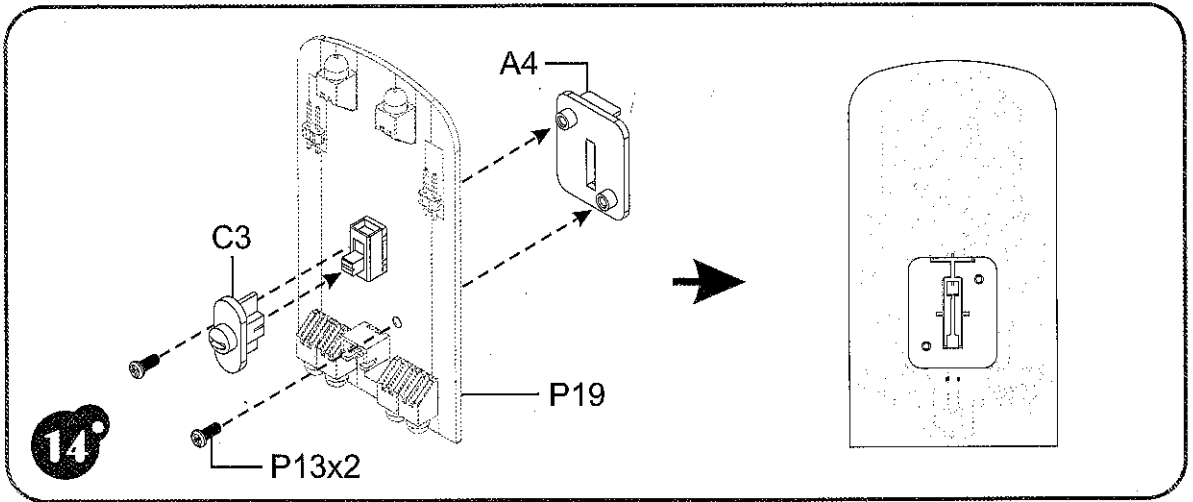

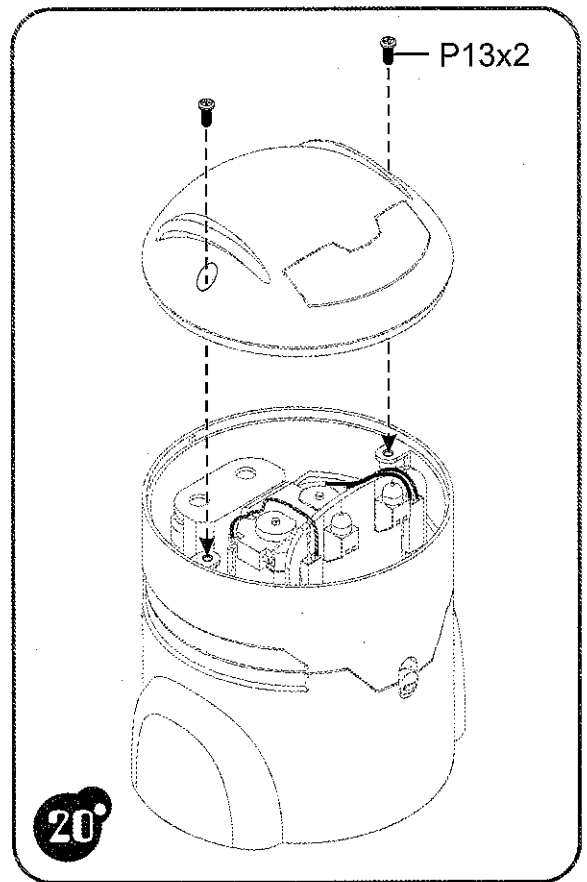
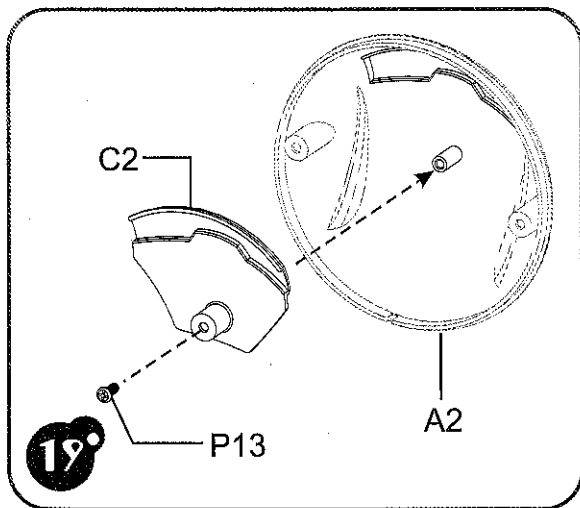
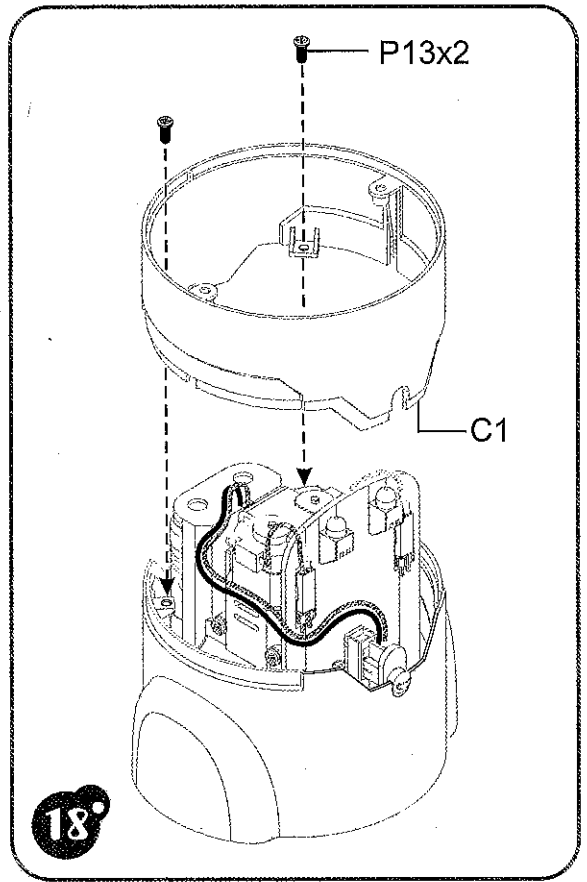
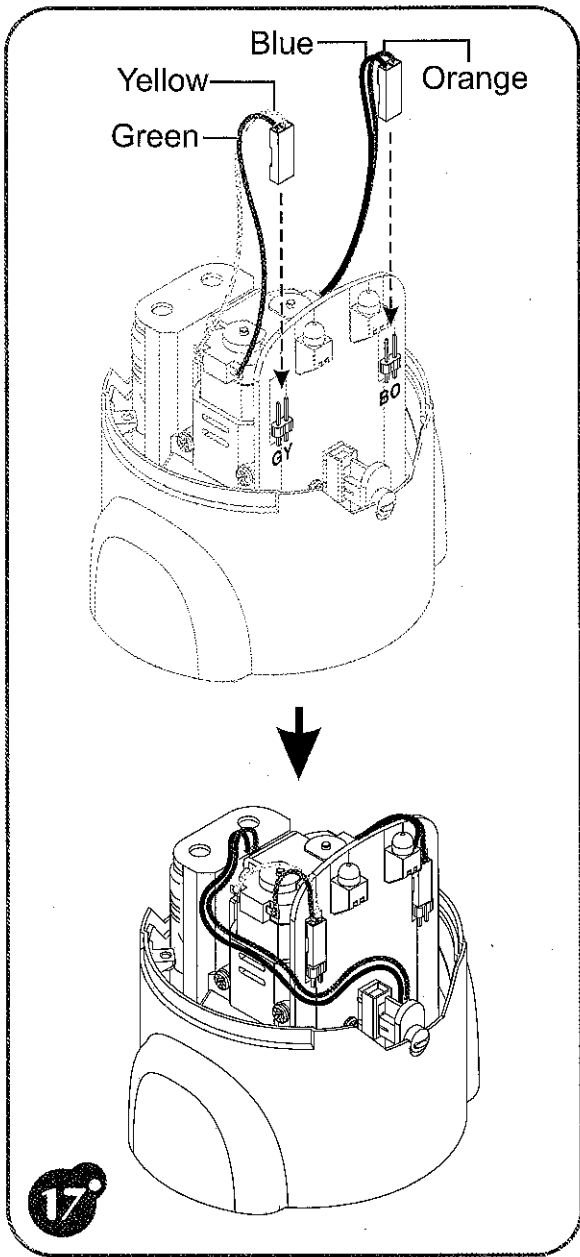

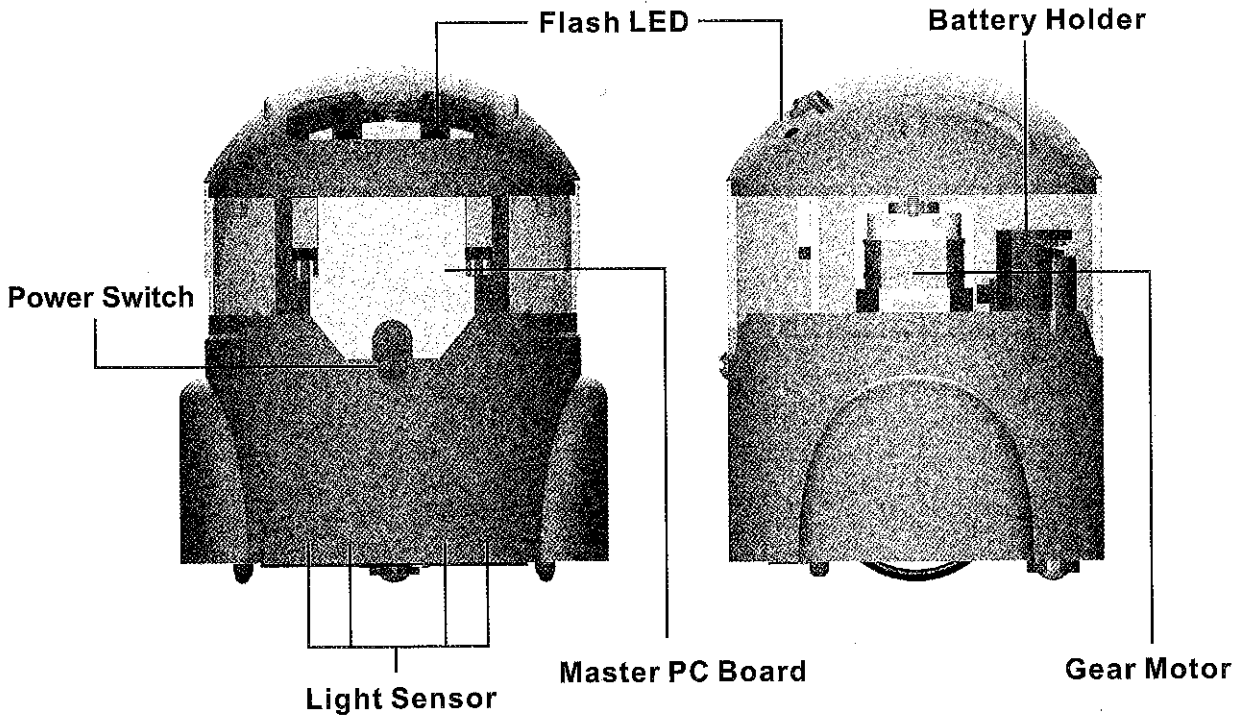

## 21° Finished Product

### 6 How It Works:

1. Using black electrical tape or thick black marker to create a route (width:18mm) on white ground.
2. Give your Robot an arcuate route, but the sharp angle (less than 90 degree) route is not suggested.
3. Switch power to 'ON' (upper position), Robot's eyes will start flashing.
4. Put your Line Tracking Robot on the route you designed, it will follow the black lines. Give it different route design and see what your Robot can do.

# 7

## Trouble Shooting:

### 1.If the Robot don't move and eyes not flash:

- Check if the '3V BAT' terminal connects properly.(Refer Step 16)
- Ensure batteries are inserted with correct polarity.
- Check if the switch is at upper position.

### 2.If the Robot don't move but eyes flash:

- Check if the motor connectors "M1", "M2" connect properly.(Refer Step 17)
- Ensure the batteries are not low.

### 3.If the Robot don't follow the line:

- Ensure motor connectors "M1", M2" are not reversed.(Refer Step 17)
- Ensure wire color of motor are same as shown on PCB.(Refer Step 17)
- Check if PCB insert to the bottom of the case.(Refer Step 16)
- Make sure the ground is white or light color, also the width of the route is no less than 18mm.

# 8

## Circuit Diagram:

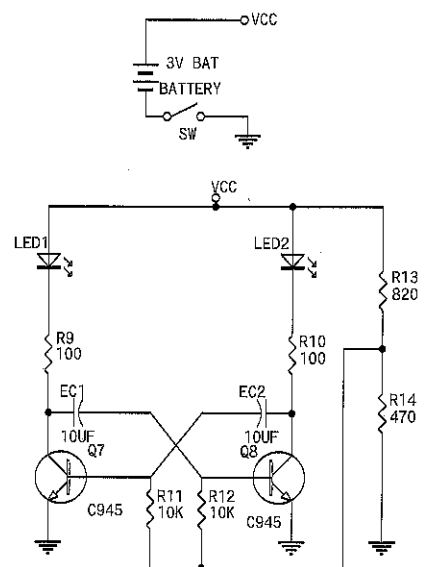
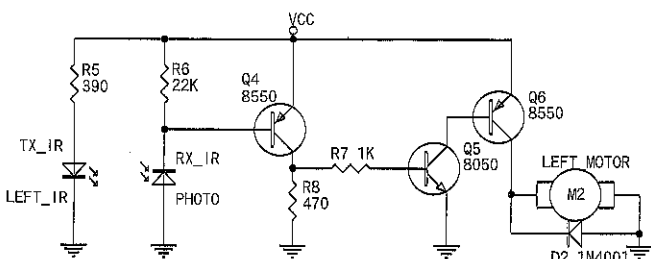
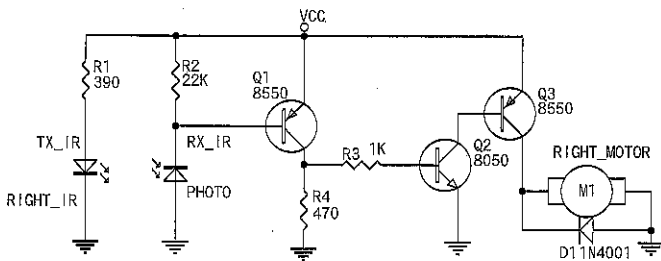

- Removal and replacement of batteries should be carried out by an adult or under adult supervision.
- Do not attempt to recharge non-rechargeable batteries. Rechargeable batteries must be removed from the toy before recharging.
- Avoid short circuiting the contacts in the battery compartment or the battery terminals.
- Remove exhausted batteries from the product to avoid leakage.
- Do not mix used batteries and new batteries or batteries of different types.
- Use of rechargeable batteries or mercury oxide batteries are not recommended for this product.