

**OPERATOR'S
INSTRUCTION MANUAL**

M-2625

**AUTO RANGING
DIGITAL MULTIMETER**

with Temperature Probe



Contents

| | |
|-----------------------------------|-------|
| 1. Safety Information | 3,4 |
| 2. Safety Symbols | 5 |
| 3. Front Plate of the Meter | 5 |
| Input Terminal | 6 |
| Function Rotary Switch | 7 |
| Function Press Button | 8,9 |
| LCD Display | 10 |
| 4. Power On Option | 11 |
| 5. Auto Power Off | 11 |
| 6. Measurement Range | 11 |
| 7. Making Measurements | 12 |
| Preparation | 12 |
| Measuring Voltage | 12 |
| Measuring DC Voltage | 13 |
| Measuring AC Voltage | 14,15 |
| Measuring Current | 16 |
| Measuring DC Current | 17-19 |
| Measuring AC Current | 19-21 |
| Measuring Resistance | 21,22 |
| Testing Diodes | 23 |
| Testing for Continuity | 24 |
| Measuring for Capacitance | 25,26 |
| Measuring Frequency | 27 |
| Measuring Duty Cycle | 28,29 |
| Measuring Temperature | 29,30 |
| 8. Maintenance | 31 |
| Battery Replacement | 31 |
| Fuse Replacement | 32 |
| 9. General Specifications | 33-35 |

Introduction

This series LCD auto ranging and auto power-off digital multimeter is a portable, compact, 3¾ digit multimeter. It is ideally suited for field, lab, shop, car, and home.

CAUTION: Read, understand and follow all Safety Rules and Operating Instructions in this manual before using this product.

1. Safety Information

Use the meter only as specified in this manual. Otherwise, the protection provided by the meter may be impaired. Refer to safety information in Table 1.

Table 1. Safety Information



Warning

To avoid possible electric shock or personal injury, follow these guidelines:

- Do not use the meter if it is damaged. Before you use the meter, inspect the case. Look for cracks or missing plastic. Pay particular attention to the insulation surrounding the connectors.
- Inspect the test leads for damaged insulation or exposed metal. Check the test leads for continuity. Replace damaged test leads before you use the meter.
- The RESPONSIBLE BODY shall be made aware that, if the equipment is used in a manner not specified by the manufacturer, the protection provided by the equipment may be impaired.
- Do not use the meter if it operates abnormally. Protection may be impaired. When in doubt, have the meter serviced.
- Do not operate the meter around explosive gas, vapor, or dust.
- Do not apply more than the rated voltage, as marked on the meter, between terminals or between any terminal and earth ground.
- Before use, verify the meter's operation by measuring a known voltage.
- When measuring current, turn off circuit power before connecting the meter in the circuit. Remember to place the meter in series with the circuit.

Table 1. Safety Information (continued)



Warning

- When servicing the meter, use only specified replacement parts.
- Use caution when working above 30VAC rms, 42V peak, or 60VDC. Such voltages pose a shock hazard.
- Avoid working alone.
- When using the probes, keep your fingers behind the finger guards on the probes.
- Connect the common test lead before you connect the live test lead. When you disconnect test leads, disconnect the live test lead first.
- Remove test leads from the meter with the battery door or portions of the cover removed or loosened.
- To avoid false readings which could lead to possible electric shock or personal injury, replace the batteries as soon as the low battery indicator () appears.
- Use only type “AA” batteries or equivalent, properly installed in the meter case, to power the meter.
- To avoid the potential for fire or electrical shock, do not connect the thermocouples to electrically live circuits.

Caution





To avoid possible electric shock or personal injury, follow these guidelines:

- Disconnect circuit power and discharge all high-voltage capacitors before testing resistance, continuity, diodes, or capacitance.
- Use the proper terminals, function, and range for your measurements.
- Before measuring current, check the meter’s fuses and turn power OFF to the circuit before connecting the meter to the circuit.

2. Safety Symbols

Symbols used on the meter and in this manual are explained in Table 2.

Table 2. International Electrical and Relative Symbols

| | | | |
|--|---------------------------|---|---------------------------------|
| ~ | AC (Alternating Current) |  | Important Information |
| ≈ | DC and AC |  | Caution, risk of electric shock |
| ≡ | DC (Direct Current) |  | Earth Ground |
| CE | Equipment Safety Standard |  | Low Battery Indicator |
|  | Double Insulated | | |

3. Front Plate of Meter

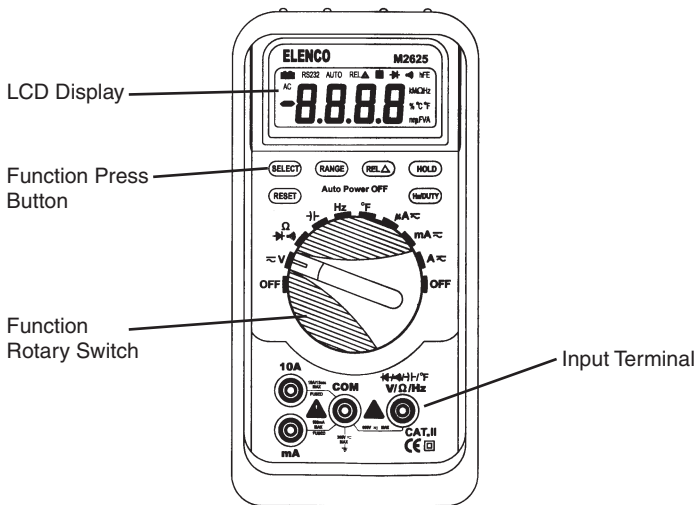

Figure 1. Front plate of the meter

Input Terminal

About terminal function refer to Table 3 and Figure 2.

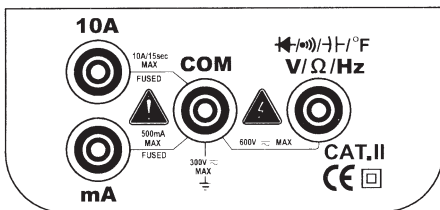
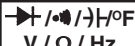

Figure 2. Input Terminal

Table 3. Input Terminal

| Terminal | Function Description |
|--|--|
|  V / Ω / Hz | Volts, ohm, diode, frequency, DUTY, temperature and capacitance measurement, and testing for continuity terminal |
| mA | Milliampere current, microampere current measurement terminal |
| COM | Common terminal for all measurements |
| 10A | Ampere current measurement terminal |

Function Rotary Switch

About function rotary switch refer to Table 4 and Figure 3.

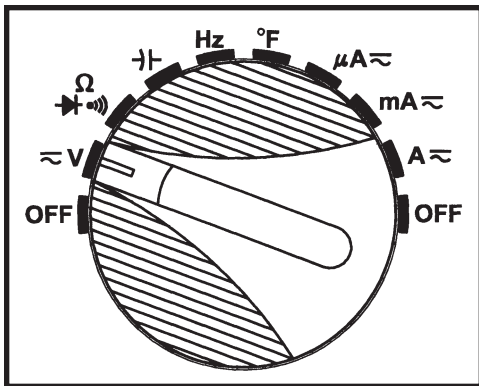

Figure 3. Function Rotary Switch

Table 4. Function Rotary Switch Symbols



| Position of Switch | Function |
|---|--|
| ~V | DC/AC voltage measurement |
|  | Resistance measurement, diode test, testing for continuity |
|  | Capacitance measurement |
| Hz | Frequency measurement / Duty cycle measurement |

Table 4. Function Rotary Switch Symbols (continued)

| Position of Switch | Function |
|----------------------|---------------------------------------|
| °F | Temperature measurement |
| $\mu\text{A}\approx$ | DC/AC microampere current measurement |
| $\text{mA}\approx$ | DC/AC milliampere current measurement |
| $\text{A}\approx$ | DC/AC ampere current measurement |
| OFF | Power off position |

Function Press Button

About press function button refer to Figure 4.

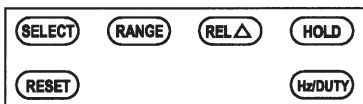

Figure 4. Function Press Button

1. **SELECT** (state choice)

There are several functions at one rotary switch position; press the **SELECT** button to select the desired function: $\approx\text{V}$, $\rightarrow\text{V}$, Ω , $\mu\text{A}\approx$, $\text{mA}\approx$, $\text{A}\approx$ range for AC or DC voltage, AC or DC current, resistance, diode, or audible continuity measurement.

2. **RANGE** (range selection)

With the power on and the meter on the auto range mode, press the **RANGE** button to select the desired measurement range manually.

The range goes from minimum to maximum by pressing the **RANGE** button multiple times, and returns to minimum after reaching the maximum range. Pressing and holding the **RANGE** button for over two seconds returns the meter to auto range. This button does not affect the frequency, capacitance, diode or continuity range.

3. **RELA** (relative measurement)

Press the **RELA** button to use the relative measuring function and a “RELA” symbol appears on the LCD. The result of the relative measurement is the difference between the measuring value and the reference value. The reference value is produced the same as the momentary value by press the **RELA** button. Press the **RELA** button again to exit this function and the “RELA” symbol disappears from the display. This button does not affect the frequency, duty cycle, diode and continuity test functions.

4. **HOLD** (data hold)

Pressing the **HOLD** button enables the data hold function and an “H” symbol appears on the display. The momentary value appears on the display. Press the **HOLD** button again to exit this function and the “H” symbol disappears from the display. This button does not affect the frequency measurement function.

5. **Hz/DUTY** (frequency and duty cycle measurement switch button)

When making a frequency, DC or AC voltage measurement, press this button to switch between the Hz or duty cycle test mode.

6. **RESET** (reset button)

Press this button to clear all values and to restart the meter.

LCD Display

About function rotary switch refer to Table 5 and Figure 5.

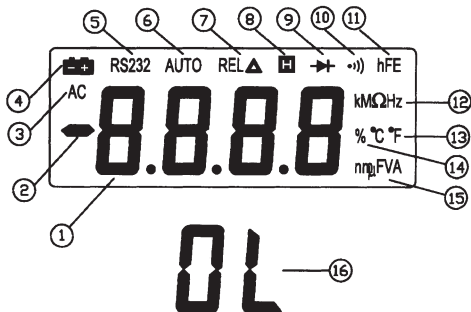

Figure 5. LCD Display

Table 5. LCD Display Symbols

| Sequ. No. | Symbol | Description |
|-----------|---|--|
| 1 | 8.8.8.8 | The display digit group |
| 2 | - | Negative symbol |
| 3 | AC | AC (alternating current) indicator |
| 4 | | Battery power is weakening |
| 5 | RS232 | Serial transmission (not used on this meter) |
| 6 | Auto | Auto range indicator |
| 7 | RELA | Relative measurement |
| 8 | | Data hold |
| 9 | | Diode symbol |
| 10 | | Audible continuity function indicator |
| 11 | hFE | Transistor gain indicator (not used) |
| 12 | Ω / kΩ / MΩ Hz / kHz / MHz | Resistance units Frequency units |

Table 5. LCD Display Symbols (continued)

| Sequ. No. | Symbol | Description |
|-----------|-----------------------------|---|
| 13 | °C °F | Temperature units (°C not used on this meter) |
| 14 | % | Percent symbol |
| 15 | mV / V nF / μF mA / A | Voltage units Capacitance units Current units |
| 16 | OL | Overload |

4. Power On Option

To release the Auto Power Off function, press and hold the **SELECT** button when the meter is on.

5. Auto Power Off

When the meter has been on for 30 minutes without any action from the user, the meter will automatically switch to the standby mode. To bring back the display, turn the rotary switch to a different position, push any button, or restart the meter.

6. Measurement Range

A measurement range determines the maximum measurement value. Most of the functions of the meter have more than one range.

1. It is important to select the correct range

- If the range is too small, “OL” shows on the display for overload.
- If the range is too large, the value of the reading will be very small with less resolution.

2. Auto range and manual range options

- In the auto range mode, the meter automatically selects the best range for the input detected.
- In the auto range mode, press the **RANGE** button to enter the manual range and select the desired range.

- When you change the measurement function, the meter will regard its auto range as current range.
- In the auto range mode, the “AUTO” symbol will appear on display and the manual range disappears.

3. Enter or exit manual range mode

- Press the **RANGE** button to select the manual range mode and the “AUTO” symbol disappears. Each press of the **RANGE** button increases the range. When the maximum range is reached, the meter restarts at the lowest range.
- Press and hold the **RANGE** button for more than two seconds to return to the autorange mode and the “AUTO” symbol will appear on the display.

7. Making Measurements

Preparation

Checking the Battery Voltage

Rotate the Function Rotary Switch to any position away from the OFF position. The battery voltage is adequate when the indication is clear and the **-+** symbol is not on the display.

If the **-+** symbol appears on the display, or nothing shows on the display at all, follow the battery replacement procedure shown in related items in this manual and replace with new batteries specified.

Measuring Voltage

Voltage is the difference in electrical potential between two points. The polarity of AC (alternating current) voltage varies over time, while the polarity of DC (direct current) voltage is constant.



To avoid the danger of electric shock, never make measurements on a circuit over 600V AC/DC (electrical potential to ground 300V DC/AC). Do not operate the Function Rotary Switch during measurement. Do not make a measurement when opening the battery cover and the meter case.

Measuring DC Voltage

1. Turn on the meter, then set up the meter to measure DC volts as shown in Figure 6.
2. Insert the black test lead into the **COM** terminal and the red test lead into the $\overline{V}/\Omega/\text{Hz}$ terminal.
3. Set the Function Rotary Switch to the $\approx V$ position (then, "AUTO" and "mV" symbols are indicated on the display).
4. Connect the black test lead to the negative side of the circuit under test and the red test lead to the positive side of the circuit. The measured value is indicated on the display. If you connect the test leads to the opposite polarity, the "-" symbol appears on the display.

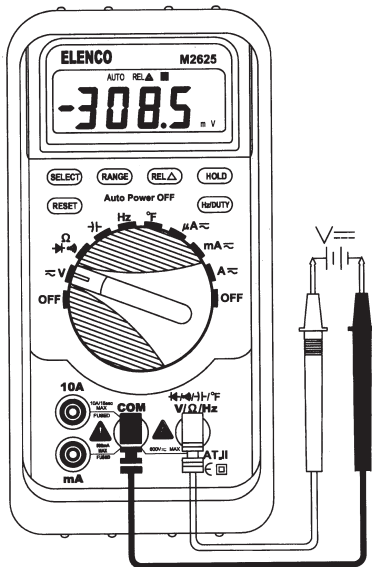

Figure 6. DC Voltage Measurement

Measuring AC Voltage

1. Turn on the meter, then set up the meter to measure AC volts as shown in Figure 7.
2. Insert the black test lead into the **COM** terminal and the red test lead into the $\frac{V}{\Omega}/Hz$ terminal.
3. Set the Function Rotary Switch to the $\approx V$ position and press **SELECT** to select the AC voltage measuring mode (then, "AUTO", "AC" and "V" symbols are indicated on the display).
4. Connect the test leads to the circuit under test, then the measured value is indicated on the display.
5. When measuring voltage less than 400mV, press the **RANGE** button to switch to manual range mode and select the AC 400mV range. Doing so will provide a better resolution for your measurement.
6. You can press the **Hz/DUTY** button to read the signal frequency or duty cycle under measurement from the display.

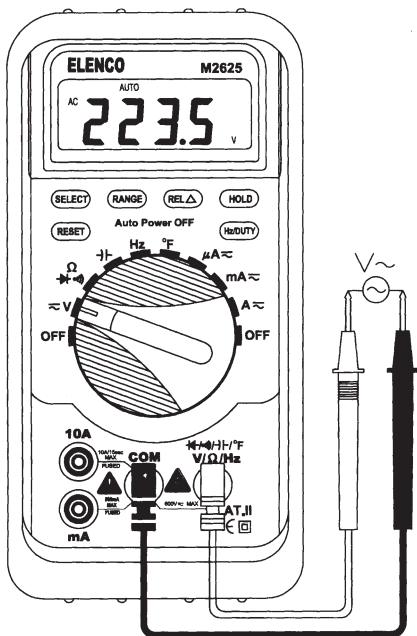

Figure 7. AC Voltage Measurement

Note: When taking a measurement of less than 20mV at the 400mV AC range, the measurement value cannot be indicated correctly. Even if shorted, the input line at the 4V AC range, 1 ~ 3 digits may remain indicated. In that case, by pressing the **RELA** button, "0" will be indicated.

Measuring Current

Warning

Never attempt an in-circuit current measurement where the open-circuit potential to earth is greater than 300V. You may damage the meter or be injured if the fuse blows during such a measurement.

Caution

To avoid possible damage to the meter or to the equipment under test, check the meter's fuses before measuring current. Use the proper terminals, function, and range for your measurement. Never place the probes across (in parallel with) any circuit or component when the leads are plugged into the current terminals. Maximum measurement time allowed at the 10A current range function is 15 seconds. If you carry on making a measurement continuously over 15 seconds, it can cause an erroneous measurement and damage the meter.

Danger

Do not operate the Function Rotary Switch during measurement. Do not make a measurement when opening the battery cover or the meter case.

Current is the flow of electrons through a conductor. To measure current, you must open the circuit under test, then place the meter in series with the circuit.

To measure AC or DC current, proceed as follows:

Measuring DC Current

1. Turn off power to the circuit. Discharge all high-voltage capacitors.
2. Turn on the meter, then set up the meter to measure DC current as shown in Figure 8.
3. Insert the black test lead into the **COM** terminal and the red lead into an input appropriate for the measurement range as shown in Table 6.
4. Connect the black test lead to the negative side of the circuit under test and the red test lead to the positive side of the circuit so the meter is in series with the circuit.
5. Turn the on the power for the circuit under test.
6. The measured value is indicated on the display.

If you connect the test leads to the reverse polarities, a “-” symbol will be shown on the display.

Note: To avoid blowing the meter’s 500mA fuse, use the **mA** terminal only if you are sure the current is less than 400mA.

Table 6. Current Measurement

| Rotary Switch | Input | Ranges |
|----------------------|-------|--------------------------------------|
| $\mu\text{A}\approx$ | mA | 40 μA / 400 μA |
| $\text{mA}\approx$ | mA | 40mA / 400mA |
| $\text{A}\approx$ | 10A | 4A / 10A |

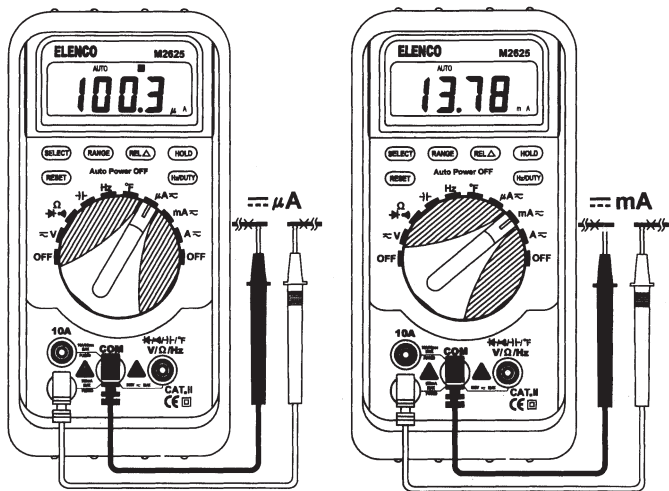

Figure 8. DC Current Measurement

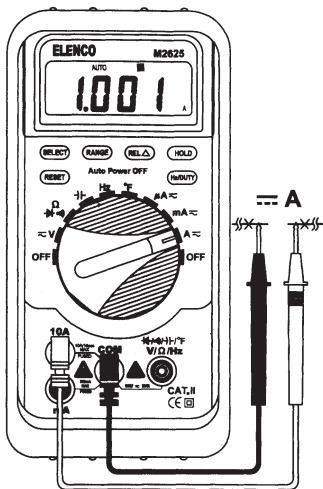

Figure 8. DC Current Measurement (continued)

Measuring AC Current

1. Turn off power to the circuit. Discharge all high-voltage capacitors.
2. Turn on the meter, then set up the meter to measure AC current as shown in Figure 9.
3. Insert the black test lead into the **COM** terminal and the red lead in an input appropriate for the measurement range as shown in Table 6.
4. Connect the test leads to the circuit under test so the meter is in series with the circuit.
5. Set the meter to AC mode by pressing the **SELECT** button (then, "AUTO" "AC" and "μA", "mA", or "A" symbols are indicated on the display).
6. Turn on the power to the circuit under test.
7. The measured value is shown on the display.

Note: To avoid blowing the meter's 500mA fuse, use the mA terminal only if you are sure the current is less than 400mA.

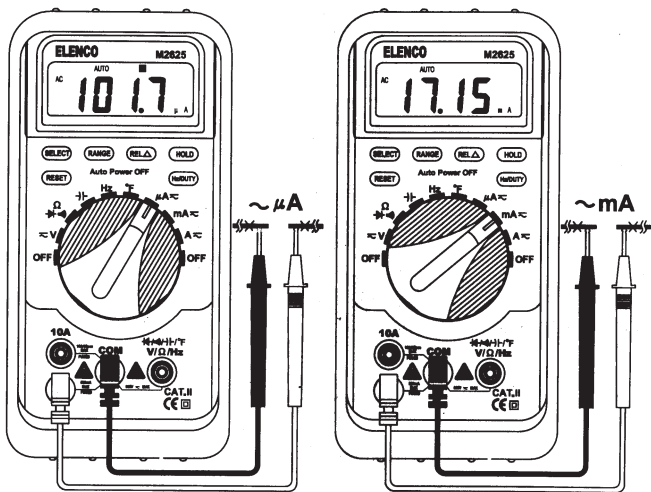

Figure 9. AC Current Measurement

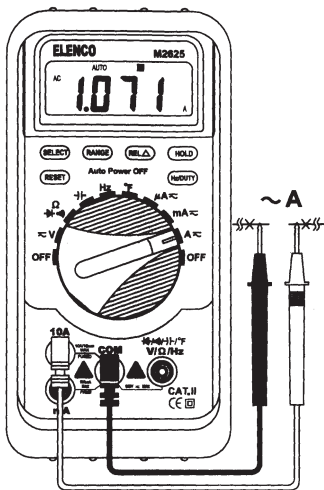

Figure 9. AC Current Measurement (continued)

Measuring Resistance

Caution

To avoid possible damage to the meter or to the equipment under test, disconnect the circuit power and discharge all high-voltage capacitors before measuring resistance.

Resistance is an opposition to current flow. The unit of resistance is the ohm (Ω). The meter measures resistance by sending a small current through the circuit.

1. To measure resistance, turn on the meter, then set up the meter as shown in Figure 10.
2. Insert the black test lead into the **COM** terminal and the red test lead into the $\frac{V}{\Omega}/Hz$ terminal.
3. Set the Function Rotary Switch to the Ω position (then, "AUTO" "OL" and "M Ω " symbols are indicated on the display).
4. Connect the test leads to both ends of the resistance under test, then the measured value is shown on the display.

Keep the following in mind when measuring resistance:

- Because the meter's test current flows through all possible paths between the probe tips, the measured value of a resistor in a circuit is often different from the resistor's rated value.
- The test leads can add 0.1Ω to 0.2Ω of error to resistance measurements. To test the leads, touch the probe tips together and read the resistance of the leads. If necessary, you can press the **RELA** button to automatically subtract its value.

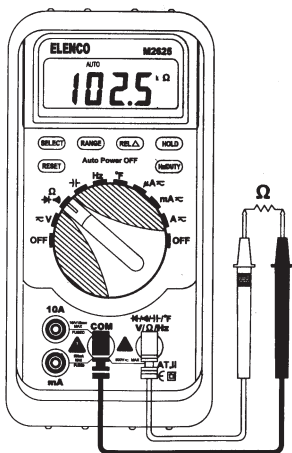

Figure 10. Resistance Measurement

Testing Diodes

Caution

To avoid possible damage to the meter or to the equipment under test, disconnect the circuit power and discharge all high-voltage capacitors before testing diodes.

Use the diode test to check diodes, transistors, silicon controlled rectifiers (SCRs), and other semiconductor devices. The test sends a current through a semiconductor junction, then measures the junction's voltage drop. A typical junction drops 0.5V to 0.8V.

To test a diode out of a circuit, set up the meter as shown in Figure 11. In a circuit, a similar diode should still indicate a forward-bias reading of 0.5V to 0.8V; however, the reverse-bias reading can vary depending on the resistance of other pathways between the probe tips.

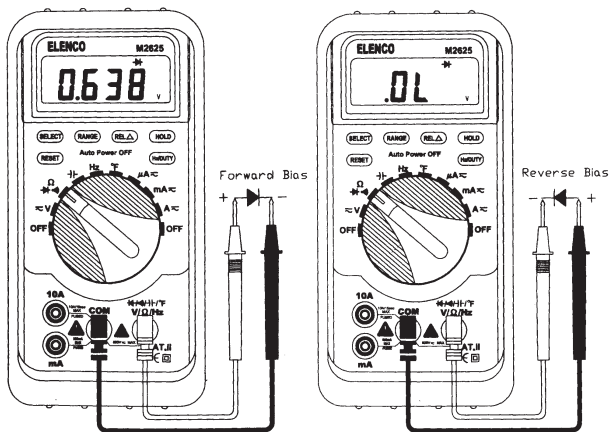

Figure 11. Diode Test

Note: Open-circuit voltage between measuring terminals is approximately 1.5V (measuring current approximately 1.5mA).

Testing for Continuity

Caution

To avoid possible damage to the meter or to the equipment under test, disconnect the circuit power and discharge all high-voltage capacitors before testing for continuity.

Continuity is the presence of a complete path for current flow. The continuity test features a beeper that sounds if a circuit is complete (the resistance less than 120Ω approx.). The beeper allows you to perform quick continuity tests without having to watch the display.

The continuity function detects intermittent opens and shorts lasting as little as 1 millisecond (0.001 second). These brief contacts cause the meter to emit a short beep. Refer to Figure 12 for continuity testing setup instructions.

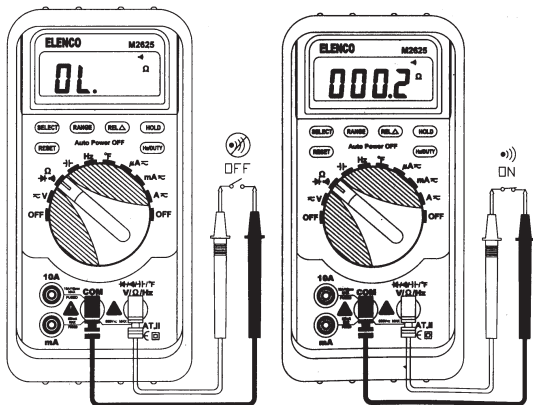

Figure 12. Continuity Test

Keep the following in mind while doing a continuity test:

- Even with the test leads shorted, the indicated value may not be “0”. This is because of the resistance of the test leads and not a fault. If necessary, you can press the **RELA** button to automatically subtract its value, then “0” will be indicated.

Measuring Capacitance

Caution

To avoid possible damage to the meter or to the equipment under test, disconnect the circuit power and discharge all high-voltage capacitors before measuring capacitance. Use the DC voltage function to confirm that the capacitor is indeed discharged.

Capacitance is the ability of a component to store an electrical charge. The unit of capacitance is the farad (F). Most capacitors are in the nanofarad (nF) to microfarad (μ F) range.

The meter measures capacitance by charging the capacitor with a known current for a known period of time according to the measuring capacitance:

Measuring capacitance $<4\mu$ F..... Measuring time is about 2 seconds

Measuring capacitance $<40\mu$ F..... Measuring time is about 7 seconds

Measuring capacitance $<100\mu$ F..... Measuring time is about 15 seconds

To measure capacitance, proceed as follows:

1. Turn on the meter, then set up the meter as shown in Figure 13.
2. Insert the black test lead into the **COM** terminal and the red test lead into the **V/Ω/HZ** terminal.
3. Set the Function Rotary Switch to the **→|** position (then, “AUTO” and “nF” symbols are indicated on the display).
4. Connect the test leads to both ends of the capacitor under test, then the measured value is shown on the display. If the capacitor is polarized, connect the red test lead to the positive lead and the black test lead to the negative lead.

The following are some tips for measuring capacitance:

- To improve the measurement accuracy of small value capacitors, press the **RELA** button with the test leads open to subtract the residual capacitance of the meter and leads.

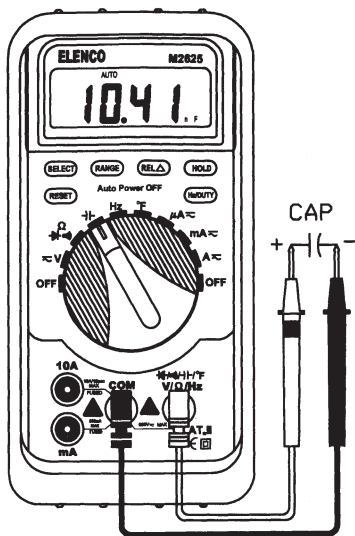

Figure 13. Capacitance Measurement

Measuring Frequency

Frequency is the number of cycles a signal completes each second. The meter measures the frequency of a voltage or current signal by counting the number of times the signal crosses a threshold level each second.

To measure frequency, proceed as follows:

1. Turn on the meter, then set up the meter as shown in Figure 14.
2. Insert the black test lead into the **COM** terminal and the red test lead into the $\frac{V}{\Omega}/\text{Hz}$ terminal.
3. Set the Function Rotary Switch to the **Hz** position (then, the “Hz” is shown on the display).
4. Connect the test leads to the circuit under test. The meter auto ranges to one of the frequency ranges, then the measured value is shown on the display.

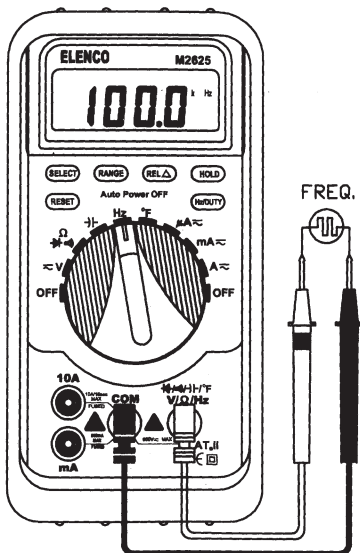

Figure 14. Frequency Measurement

Measuring Duty Cycle

Duty cycle (or duty factor) is the percentage of time a signal is above or below a trigger level during one cycle (Figure 16).

To measure duty cycle, proceed as follows:

1. Turn on the meter, then set up the meter as shown in Figure 15.
2. Insert the black test lead into the **COM** terminal and the red test lead into the $\frac{10}{100/1000}$ **V/Ω/Hz** terminal.
3. Set the Function Rotary Switch to the **Hz** position. Then press **Hz/DUTY** once to select DUTY Cycle measurement (then, a “%” symbol is indicated on the display).
4. Connect the test leads to the circuit under test. The measured value is shown on the display.

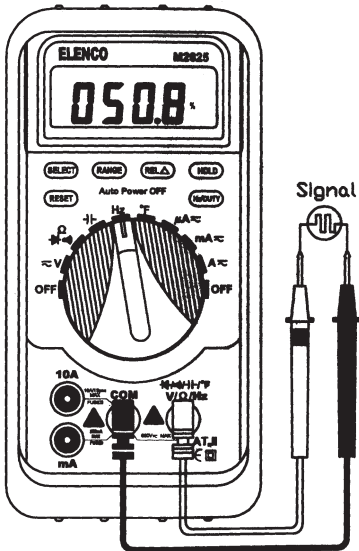

Figure 15. Duty Cycle Measurement

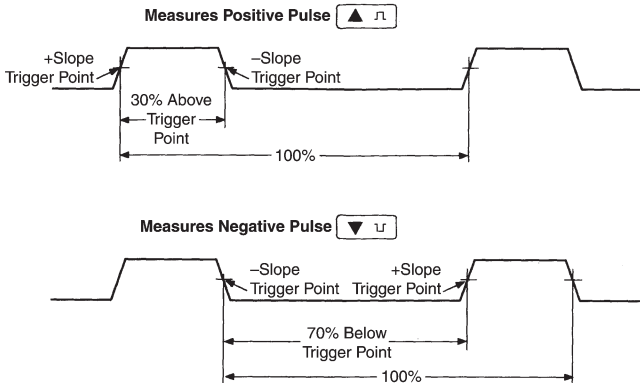

Figure 16. Duty Cycle Measurement

Measuring Temperature

Warning

To avoid the potential of fire or electrical shock, do not connect the thermocouples to electrically live circuits.

To measure temperature, proceed as follows:

1. Turn on the meter, then set up the meter as shown in Figure 17.
2. Set the Function Rotary Switch to the **°F** position (then, the “AUTO” and “°F” symbols are indicated on the display).
3. Plug the positive leg (+) of the type K thermocouples into the **V/Ω/Hz** terminal and the negative leg (-) into the **COM** terminal and read the value on the display. The range of the TP-03 thermocouples is $-58^{\circ}\text{F} \sim +752^{\circ}\text{F}$.
4. Opening the input will display the temperature at the meter terminals.

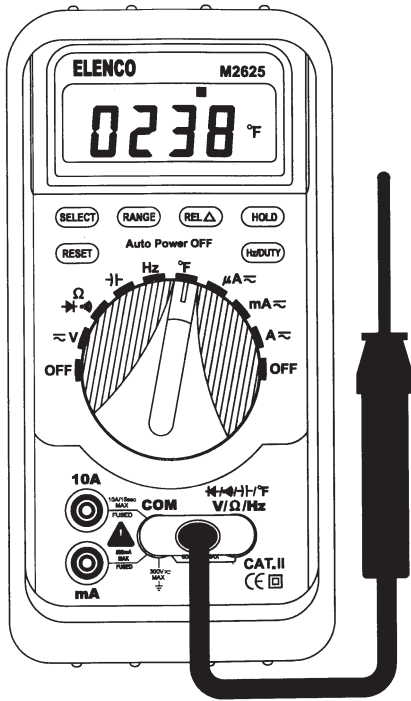

Figure 17. Temperature Measurement

8. Maintenance

General Maintenance

Periodically wipe the case with a damp cloth and mild detergent. Do not use abrasives or solvents. Dirt or moisture in the terminals can affect readings. Clean the terminals as follows:

1. Turn the meter off and remove all test leads.
2. Shake out any dirt that may be in the terminals.
3. Soak a new swab with alcohol. Work the swab around each terminal.

Replacing the Batteries

Replace the batteries with two “AA” batteries (R6P) or equivalent.

Warning

To avoid false readings, which could lead to possible electric shock or personal injury, replace the batteries as soon as the low battery indicator () appears.

Replace the batteries as follows (refer to Figure 18):

1. Turn the Function Rotary Switch to the **OFF** position and remove the test leads from the terminals.
2. Remove the battery door by using a screwdriver to turn the battery door screw counterclockwise.
3. Replace the batteries. Secure the door by turning the screws clockwise.

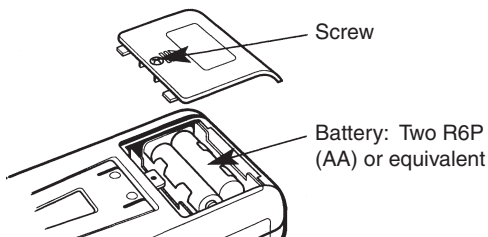

Figure 18. Battery Replacement

Replacing the Fuses

Warning

To avoid electrical shock or damage to the meter, only use replacement fuses $\varnothing 5 \times 20$ 0.5A/250V FAST or $\varnothing 6 \times 25$ 10A/250V FAST.

Referring to Figure 19, examine or replace the meter's fuses as follows:

1. Turn the Function Rotary Switch to the **OFF** position and remove the test leads from the terminals.
2. Remove the holster from the meter. Then, using a screwdriver, unscrew the two screws on the back case and remove it.
3. Remove either fuse by gently prying one end loose, then sliding the fuse out of its bracket.
4. Install **ONLY** the specified replacement fuses with the amperage, voltage, and speed ratings: $\varnothing 5 \times 20$ 0.5A/250V FAST or $\varnothing 6 \times 25$ 10A/250V FAST.
5. Reinstall the back case. Secure the back case by turning the screws clockwise.

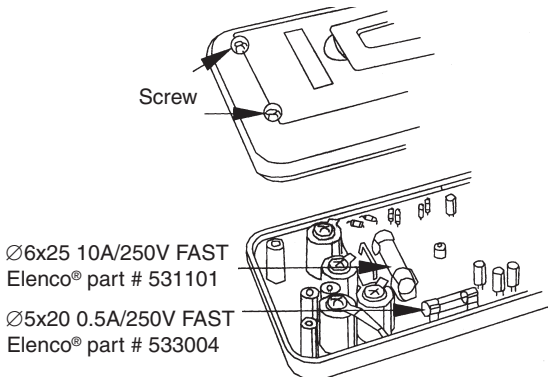

Figure 19. Fuse Replacement

9. General Specifications

Display: 3¾ digit LCD with a maximum reading of 3999.

Range Control: Auto range or manual range control.

Polarity: Automatic negative polarity indication.

Zero Adjustment: Automatic

Overrange Indication: Only the “OL” display.

Low Battery: The symbol “” is displayed when the battery voltage is below approximately 2.4V.

Auto Power Off: 30 minutes after stopping the switch or no key-input, the meter automatically enters the power off mode.

Safety Standards: CE EMC/LVD. The meter is up to the standards of IEC1010 pollution degree 2; overvoltage category II (double insulation).

Operating Environment: Temperature 32° - 104°F (0° to 40°C), humidity <80% RH.

Storage Environment: Temperature -4° - 140°F (-20° to 60°C), humidity <85% RH.

Power: Two 1.5V “AA” batteries.

Dimensions: 6 3/32”/155mm (H) x 2 15/16”/75mm (W) x 1 5/16”/33mm (D)

Weight: Approx. 9.2oz./260g. (including battery and holster)

Detailed Accuracy Specifications

Accuracies are \pm (% of reading + number in last digit) at 73°F \pm 41°F/23°C \pm 5°C, <75% RH.

The detailed accuracy specifications are shown in Tables 7 to 18.

Table 7. DCV Detailed Accuracy Specifications

| Range | Resolution | Accuracy | Note |
|-------|------------|------------------------------|--|
| 400mV | 0.1mV | $\pm(0.5\% \text{ rdg} + 5)$ | Input Resistance: 10M Ω Overload Protect: 400mV range 250V rms. The rest 600VDC or 600VAC rms. |
| 4V | 1mV | | |
| 40V | 10mV | | |
| 400V | 100mV | | |
| 600V | 1V | $\pm(0.8\% \text{ rdg} + 5)$ | |

Table 8. ACV Detailed Accuracy Specifications

| Range | Resolution | Accuracy | Note |
|-------|------------|------------------------------|---|
| 400mV | 0.1mV | $\pm(1.5\% \text{ rdg} + 8)$ | Frequency Response: 50Hz - 400Hz Input Resistance: 10M Ω Overload Protect: 400mV range 250V rms. The rest 600VDC or 600VAC rms. |
| 4V | 1mV | $\pm(0.8\% \text{ rdg} + 5)$ | |
| 40V | 10mV | | |
| 400V | 100mV | | |
| 600V | 1V | $\pm(1.2\% \text{ rdg} + 5)$ | |

Table 9. DCA Detailed Accuracy Specifications

| Range | Resolution | Accuracy | Note |
|-------------|-------------|------------------------------|--|
| 40 μ A | 0.1 μ A | $\pm(2.0\% \text{ rdg} + 5)$ | Overload Protect: Fast fuse 0.5A/250V and fast fuse 10A/250V. 10A for 15sec. maximum Input Voltage Drop: $\leq 0.4V$ |
| 400 μ A | 1 μ A | | |
| 40mA | 10 μ A | $\pm(1.5\% \text{ rdg} + 5)$ | |
| 400mA | 100 μ A | | |
| 4A | 1mA | $\pm(2.0\% \text{ rdg} + 5)$ | |
| 10A | 10mA | | |

Table 10. ACA Detailed Accuracy Specifications

| Range | Resolution | Accuracy | Note |
|-------------|-------------|------------------------------|---|
| 40 μ A | 0.1 μ A | $\pm(2.5\% \text{ rdg} + 3)$ | Overload Protect: Fast fuse 0.5A/250V and fast fuse 10A/250V. 10A for 15sec. maximum Input Voltage Drop: $\leq 0.4V$ Frequency Response: 50Hz - 400Hz |
| 400 μ A | 1 μ A | | |
| 40mA | 10 μ A | $\pm(2.0\% \text{ rdg} + 5)$ | |
| 400mA | 100 μ A | | |
| 4A | 1mA | $\pm(2.5\% \text{ rdg} + 5)$ | |
| 10A | 10mA | | |

Table 11. Resistance Detailed Accuracy Specifications

| Range | Resolution | Accuracy | Note |
|---------------|---------------|------------------------------|----------------------------|
| 400 Ω | 100m Ω | $\pm(1.0\% \text{ rdg} + 5)$ | Overload Protect: 250V rms |
| 4k Ω | 1 Ω | | |
| 40k Ω | 10 Ω | | |
| 400k Ω | 100 Ω | | |
| 4M Ω | 1k Ω | | |
| 40M Ω | 10k Ω | $\pm(2.0\% \text{ rdg} + 5)$ | |

Table 12. Capacitance Detailed Accuracy Specifications

| Range | Resolution | Accuracy | Note |
|-------------|------------|-------------------------------|----------------------------|
| 40nF | 10pF | $\pm(3.5\% \text{ rdg} + 10)$ | Overload Protect: 250V rms |
| 400nF | 100pF | $\pm(3.0\% \text{ rdg} + 5)$ | |
| 4 μ F | 1nF | | |
| 40 μ F | 10nF | | |
| 100 μ F | 100nF | $\pm(3.5\% \text{ rdg} + 5)$ | |

Table 13. Diode Detailed Accuracy Specifications

| Range | Description | Note |
|--|--|--|
|  | Display reads approximate forward voltage of diode | Forward DC current approx. 1.5mA; Reversed DC voltage approx. 1.5V. |

Overload protection: 250V rms

Table 14. Frequency & Duty Cycle Detailed Accuracy Specifications

| Range | Resolution | Accuracy | Sensitivity | Note |
|----------------------|-----------------------|------------------------------|--|--|
| 5.12Hz - 10MHz | 0.001Hz - 10kHz | $\pm(0.1\% \text{ rdg} + 5)$ | $\leq 1\text{MHz}$: 0.7V rms; $> 1\text{MHz}$: 1.5V rms | Overload Protect: 250V rms Duty Cycle: 10Hz-1kHz |
| 0.1% - 99.9% | 0.1% | $\pm(2.5\% \text{ rdg} + 5)$ | 1.5V rms | |

Table 15. Temperature Detailed Accuracy Specifications

| Range | Accuracy | Note |
|---------------|----------------------------------|------------------------|
| -58°F - 752°F | $\pm 0.75\% \pm 5^\circ\text{F}$ | 5°F (room temperature) |
| | $\pm 1.5\% \pm 5^\circ\text{F}$ | |

Elenco® Electronics, Inc.

150 Carpenter Avenue

Wheeling, IL 60090

(847) 541-3800

Web site: www.elenco.com

e-mail: elenco@elenco.com