

# ELECTRONIC PLAYGROUND™ and Learning Center

"Just Like You Remember"



*All Systems Go!*



**No Tools  
or Soldering  
Required!**

**A Great Introduction to the World of Electronics!**

**Step by Step Illustrated Manual • EP-60**



**ELENCO**  
Learn by doing.

# TABLE OF CONTENTS

<b>Definition of Terms</b>	Page 3	<b>Test Your Knowledge #2</b>	42
<b>Answers to Quizzes</b>	5	Experiment #25: The Magnetic Bridge	42
<b>Introduction to Basic Components</b>	6	Experiment #26: The Lighthouse	43
Experiment #1: The Light Bulb	8	Experiment #27: Electronic Sound	44
<b>More About Resistors</b>	10	Experiment #28: The Alarm	46
Experiment #2: Brightness Control	11	Experiment #29: Morse Code	47
Experiment #3: Resistors in Series	12	Experiment #30: Siren	48
Experiment #4: Parallel Pipes	13	Experiment #31: Electronic Rain	49
Experiment #4B: Comparison of Parallel Currents	14	Experiment #32: The Space Gun	50
Experiment #5: Combined Circuit	15	Experiment #33: Electronic Noisemaker	51
Experiment #6: Water Detector	16	Experiment #34: Drawing Resistors	52
<b>Introduction to Capacitors</b>	17	Experiment #35: Electronic Kazoo	53
Experiment #7: Slow Light Bulb	19	Experiment #36: Electronic Keyboard	54
Experiment #8: Small Dominates Large	20	Experiment #37: Fun with Water	55
Experiment #9: Large Dominates Small	21	Experiment #38: Transistor Radio	56
Experiment #10: Make Your Own Battery	22	Experiment #39: Radio Announcer	58
<b>Test Your Knowledge #1</b>	23	Experiment #40: Radio Jammer	59
<b>Introduction to Diodes</b>	23	Experiment #41: Blinking Lights	60
Experiment #11: One - Way Current	24	Experiment #42: Noisy Blinker	61
Experiment #12: One - Way Light Bulbs	25	Experiment #43: One Shot	62
<b>Introduction to Transistors</b>	26	Experiment #44: Alarm With Shut - Off Timer	63
Experiment #13: The Electronic Switch	27	Experiment #45: The Flip - Flop	64
Experiment #14: The Current Amplifier	28	Experiment #46: Finger Touch Lamp With Memory	65
Experiment #15: The Substitute	29	Experiment #47: This OR That	66
Experiment #16: Standard Transistor Biasing Circuit	30	Experiment #48: Neither This NOR That	67
Experiment #17: Very Slow Light Bulb	31	Experiment #49: This AND That	68
Experiment #18: The Darlington	32	Experiment #50: Audio AND, NAND	69
Experiment #19: The Finger Touch Lamp	33	Experiment #51: Logic Combination	70
Experiment #20: The Battery Immunizer	34	Experiment #52: Auto-Off Night-Light	71
Experiment #21: The Voltmeter	35	Experiment #53: Storing Electricity	72
Experiment #22: 1.5 Volt Battery Tester	36	Experiment #54: Strobe Light	73
Experiment #23: 9 Volt Battery Tester	37	Experiment #55: Grandfather Clock	74
Experiment #24: The Anti-Capacitor	38	Experiment #56: Time delay of 3 sec to 30 min	75
<b>Introduction to Inductors and Transformers</b>	40	Experiment #57: The Slow Motion Sunrise/Sunset Light	76
		Experiment #58: OHMmeter	77
		Experiment #59: The Metal Detector	78
		Experiment #60: Inverter Circuit	79
		<b>Test Your Knowledge #3</b>	80
		<b>Troubleshooting Guide</b>	80



**WARNING: This product produces flashes that may trigger epilepsy in sensitized individuals.**

---

## DEFINITION OF TERMS

(Most of these will be introduced and explained during the experiments).

<b>AC</b>	Common abbreviation for alternating current.	<b>Coil</b>	When something is wound in a spiral. In electronics this describes inductors, which are coiled wires.
<b>Alternating Current</b>	A current that is constantly changing.	<b>Collector</b>	The controlled input of an NPN bipolar junction transistor.
<b>AM</b>	Amplitude modulation. The amplitude of the radio signal is varied depending on the information being sent.	<b>Color Code</b>	A method for marking resistors using colored bands.
<b>Amp</b>	Shortened name for ampere.	<b>Conductor</b>	A material that has low electrical resistance.
<b>Ampere (A)</b>	The unit of measure for electric current. Commonly shortened to amp.	<b>Counter-Clockwise</b>	Opposite the direction in which the hands of a clock rotate.
<b>Amplitude</b>	Strength or level of something.	<b>Current</b>	A measure of how fast electrons are flowing in a wire or how fast water is flowing in a pipe.
<b>Analogy</b>	A similarity in some ways.	<b>Darlington</b>	A transistor configuration which has high current gain and input resistance.
<b>AND Gate</b>	A type of digital circuit which gives a HIGH output only if all of its inputs are HIGH.	<b>DC</b>	Common abbreviation for direct current.
<b>Antenna</b>	Inductors used for sending or receiving radio signals.	<b>Decode</b>	To recover a message.
<b>Astable Multivibrator</b>	A type of transistor configuration in which only one transistor is on at a time.	<b>Detector</b>	A device or circuit which finds something.
<b>Atom</b>	The smallest particle of a chemical element, made up of electrons, protons, etc.	<b>Diaphragm</b>	A flexible wall.
<b>Audio</b>	Electrical energy representing voice or music.	<b>Differential Pair</b>	A type of transistor configuration.
<b>Base</b>	The controlling input of an NPN bipolar junction transistor.	<b>Digital Circuit</b>	A wide range of circuits in which all inputs and outputs have only two states, such as high/low.
<b>Battery</b>	A device which uses a chemical reaction to create an electric charge across a material.	<b>Diode</b>	An electronic device that allows current to flow in only one direction.
<b>Bias</b>	The state of the DC voltages across a diode or transistor.	<b>Direct Current</b>	A current that is constant and not changing.
<b>Bipolar Junction Transistor (BJT)</b>	A widely used type of transistor.	<b>Disc Capacitor</b>	A type of capacitor that has low capacitance and is used mostly in high frequency circuits.
<b>Bistable Switch</b>	A type of transistor configuration, also known as the flip-flop.	<b>Electric Field</b>	The region of electric attraction or repulsion around a constant voltage. This is usually associated with the dielectric in a capacitor.
<b>BJT</b>	Common abbreviation for Bipolar Junction Transistor.	<b>Electricity</b>	A flow of electrons between atoms due to an electrical charge across the material.
<b>Capacitance</b>	The ability to store electric charge.	<b>Electrolytic Capacitor</b>	A type of capacitor that has high capacitance and is used mostly in low frequency circuits. It has polarity markings.
<b>Capacitor</b>	An electrical component that can store electrical pressure (voltage) for periods of time.		
<b>Carbon</b>	A chemical element used to make resistors.		
<b>Clockwise</b>	In the direction in which the hands of a clock rotate.		

<b>Electron</b>	A sub-atomic particle that has an electrical charge.	<b>LED</b>	Common abbreviation for light emitting diode.
<b>Electronics</b>	The science of electricity and its applications.	<b>Light Emitting Diode</b>	A diode made from gallium arsenide that has a turn-on energy so high that light is generated when current flows through it.
<b>Emitter</b>	The output of an NPN bipolar junction transistor.	<b>Magnetic Field</b>	The region of magnetic attraction or repulsion around a magnet or an AC current. This is usually associated with an inductor or transformer.
<b>Encode</b>	To put a message into a format which is easier to transmit.	<b>Magnetism</b>	A force of attraction between certain metals. Electric currents also have magnetic properties.
<b>Farad, (F)</b>	The unit of measure for capacitance.	<b>Meg- (M)</b>	A prefix used in the metric system. It means a million of something.
<b>Feedback</b>	To adjust the input to something based on what its output is doing.	<b>Micro- (<math>\mu</math>)</b>	A prefix used in the metric system. It means a millionth (0.000,001) of something.
<b>Flip-Flop</b>	A type of transistor configuration is which the output changes every time it receives an input pulse.	<b>Microphone</b>	A device which converts sound waves into electrical energy.
<b>FM</b>	Frequency modulation. The frequency of the radio signal is varied depending on the information being sent.	<b>Milli- (m)</b>	A prefix used in the metric system. It means a thousandth (0.001) of something.
<b>Forward-Biased</b>	The state of a diode when current is flowing through it.	<b>Modulation</b>	Methods used for encoding radio signals with information.
<b>Frequency</b>	The rate at which something repeats.	<b>Momentum</b>	The power of a moving object.
<b>Friction</b>	The rubbing of one object against another. It generates heat.	<b>Morse Code</b>	A code used to send messages with long or short transmit bursts.
<b>Gallium Arsenide</b>	A chemical element that is used as a semiconductor.	<b>NAND Gate</b>	A type of digital circuit which gives a HIGH output if some of its inputs are LOW.
<b>Generator</b>	A device which uses steam or water pressure to move a magnet near a wire, creating an electric current in the wire.	<b>NOR Gate</b>	A type of digital circuit which gives a HIGH output if none of its inputs are HIGH.
<b>Germanium</b>	A chemical element that is used as a semiconductor.	<b>NOT Gate</b>	A type of digital circuit whose output is opposite its input.
<b>Ground</b>	A common term for the 0V or “-” side of a battery or generator.	<b>NPN</b>	Negative-Positive-Negative, a type of transistor construction.
<b>Henry (H)</b>	The unit of measure for Inductance.	<b>Ohm’s Law</b>	The relationship between voltage, current, and resistance.
<b>Inductance</b>	The ability of a wire to create an induced voltage when the current varies, due to magnetic effects.	<b>Ohm, (<math>\Omega</math>)</b>	The unit of measure for resistance.
<b>Inductor</b>	A component that opposes changes in electrical current.	<b>OR Gate</b>	A type of digital circuit which gives a HIGH output if any of its inputs are HIGH.
<b>Insulator</b>	A material that has high electrical resistance.	<b>Oscillator</b>	A circuit that uses feedback to generate an AC output.
<b>Integrated Circuit</b>	A type of circuit in which transistors, diodes, resistors, and capacitors are all constructed on a semiconductor base.	<b>Parallel</b>	When several electrical components are connected between the same points in the circuit.
<b>Kilo- (K)</b>	A prefix used in the metric system. It means a thousand of something.		

<b>Pico- (p)</b>	A prefix used in the metric system. It means a millionth of a millionth (0.000,000,000,001) of something.	<b>Silicon</b>	The chemical element most commonly used as a semiconductor.
<b>Pitch</b>	The musical term for frequency.	<b>Solder</b>	A tin-lead metal that becomes a liquid when heated to above 360 degrees. In addition to having low resistance like other metals, solder also provides a strong mounting that can withstand shocks.
<b>Printed Circuit Board</b>	A board used for mounting electrical components. Components are connected using metal traces "printed" on the board instead of wires.	<b>Speaker</b>	A device which converts electrical energy into sound.
<b>Receiver</b>	The device which is receiving a message (usually with radio).	<b>Switch</b>	A device to connect ("closed" or "on") or disconnect ("open" or "off") wires in an electric circuit.
<b>Resistance</b>	The electrical friction between an electric current and the material it is flowing through; the loss of energy from electrons as they move between atoms of the material.	<b>Transformer</b>	A device which uses two coils to change the AC voltage and current (increasing one while decreasing the other).
<b>Resistor</b>	Components used to control the flow of electricity in a circuit. They are made of carbon.	<b>Transient</b>	Temporary. Used to describe DC changes to circuits.
<b>Resistor-Transistor-Logic (RTL)</b>	A type of circuit arrangement used to construct digital gates.	<b>Transistor</b>	An electronic device that uses a small amount of current to control a large amount of current.
<b>Reverse-Biased</b>	When there is a voltage in the direction of high-resistance across a diode.	<b>Transmitter</b>	The device which is sending a message (usually with radio).
<b>Saturation</b>	The state of a transistor when the circuit resistances, not the transistor itself, are limiting the current.	<b>Truth Table</b>	A table which lists all the possible combinations of inputs and outputs for a digital circuit.
<b>Schematic</b>	A drawing of an electrical circuit that uses symbols for all the components.	<b>Tungsten</b>	A highly resistive material used in light bulbs.
<b>Semiconductor</b>	A material that has more resistance than conductors but less than insulators. It is used to construct diodes, transistors, and integrated circuits.	<b>Tuning Capacitor</b>	A capacitor whose value is varied by rotating conductive plates over a dielectric.
<b>Series</b>	When electrical components are connected one after the other.	<b>Variable Resistor</b>	A resistor with an additional arm contact that can move along the resistive material and tap off the desired resistance.
<b>Short Circuit</b>	When wires from different parts of a circuit (or different circuits) connect accidentally.	<b>Voltage</b>	A measure of how strong an electric charge across a material is.
		<b>Voltage Divider</b>	A resistor configuration to create a lower voltage.
		<b>Volts (V)</b>	The unit of measure for voltage.

---

## QUIZ ANSWERS

**First Quiz:** 1. electrons; 2. short; 3. battery; 4. increase; 5. insulators, conductors; 6. decreases, increases; 7. decreases; 8. voltage; 9. alternating, direct; 10. increases, decreases.

**Second Quiz:** 1. reverse; 2. LEDs; 3. amplifier; 4. integrated; 5. saturated; 6. alternating, direct; 7. decreases, increases; 8. magnetic; 9. increases; 10. twice

**Third Quiz:** 1. feedback; 2. air, pressure; 3. decreases; 4. radio; 5. inductors; 6. OR; 7. NAND

# INTRODUCTION TO BASIC COMPONENTS

Welcome to the exciting world of Electronics! Before starting the first experiment, let's learn about some of the basic electronic components. **Electricity** is a flow of sub-atomic (very, very, very, small) particles, called **electrons**. The electrons move from atom to atom when an electrical charge is applied across the material. Electronics will be easier to understand if you think of the flow of electricity through circuits as water flowing through pipes (this will be referred to as the water pipe analogy).

Wires: Wires can be thought of as large, smooth pipes that allow water to pass through easily. Wires are made of metals, usually copper, that offer very low resistance to the flow of electricity. When wires from different parts of a circuit connect accidentally we have a **short circuit** or simply a short. You probably know from the movies that this usually means trouble. You must always make sure that the metal from different wires never touches except at springs where the wires are connecting to each other. The electric **current**, expressed in **amperes** (A, named after Andre Ampere who studied the relationship between electricity and magnetism) or milliamps (mA, 1/1000 of an ampere), is a measure of how fast electrons are flowing in a wire just as a water current describes how fast water is flowing in a pipe.

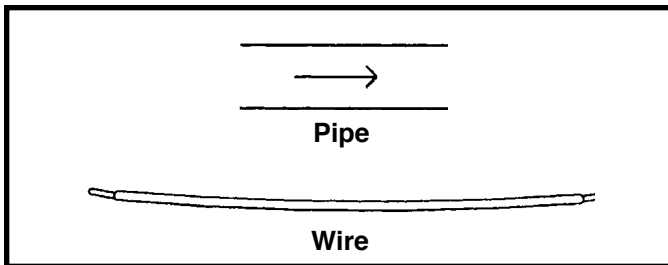

The Battery: To make water flow through a pipe we need a pump. To make electricity flow through wires we use a **battery** or a **generator** to create an electrical charge across the wires. A battery does this by using a chemical reaction and has the advantage of being simple, small, and portable. If you move a magnet near a wire then electricity will flow in the wire. This is done in a generator. The electric power companies have enormous generators driven by steam or water pressure to produce electricity for your home.

The **voltage**, expressed in **volts** (V, and named after Alessandro Volta who invented the battery in 1800), is a measure of how strong the electric charge from your battery or generator is, similar to the water pressure. Your Electronic Playground uses a 9V battery. Notice the "+" and "-" signs on the battery. These indicate which direction the battery will "pump" the electricity, similarly to how a water pump can only pump water in one direction. The 0V or "-" side of the battery is often referred to as "**ground**". Notice that just to the right of the battery pictured below is a symbol, the same symbol you see next to the battery holder. Engineers are not very good at drawing pictures of their parts, so when engineers draw pictures of their circuits they use symbols like this to represent them. It also takes less time to draw and takes up less space on the page. Note that wires are represented simply by lines on the page.

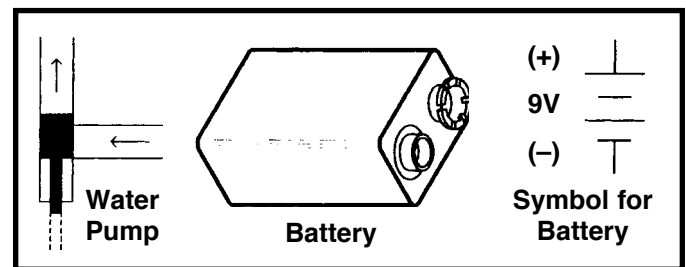

The Switch: Since you don't want to waste water when you are not using it, you have a faucet or valve to turn the water on and off. Similarly, you use a switch to turn the electricity on and off in your circuit. A switch connects (the "closed" or "on" position) or disconnects (the "open" or "off" position) the wires in your circuit. As with the battery, the switch is represented by a symbol, shown

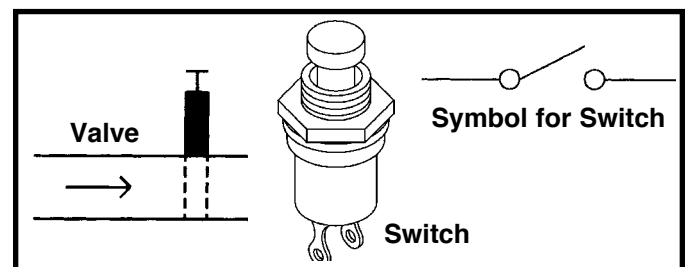

below on the right.

The Resistor: Why is the water pipe that goes to your kitchen faucet smaller than the one that comes to your house from the water company? And why is it much smaller than the main water line that supplies water to your entire town? Because you don't need so much water. The pipe size limits the water flow to what you actually need. Electricity works in a similar manner, except that wires have so little resistance that they would have to be very, very thin to limit the flow of electricity. They would be hard to handle and break easily. But the water flow through a large pipe could also be limited by filling a section of the pipe with rocks (a thin screen would keep the rocks from falling over), which would

slow the flow of water but not stop it. Resistors are like rocks for electricity, they control how much electric current flows. The **resistance**, expressed in **ohms** ( $\Omega$ , named after George Ohm), kilohms ( $K\Omega$ , 1000 ohms), or megohms ( $M\Omega$ , 1,000,000 ohms) is a measure of how much a resistor resists the flow of electricity. To increase the water flow through a pipe you can increase the water pressure or use less rocks. To increase the electric current in a circuit you can increase the voltage or use a lower value resistor (this will be demonstrated in a moment). The symbol for the resistor is shown on the right.

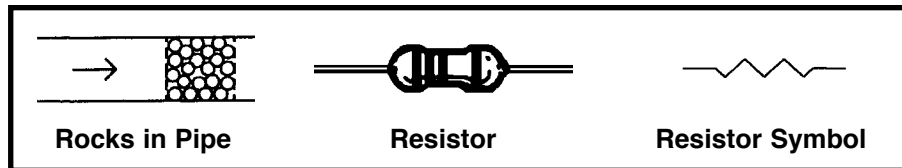

# EXPERIMENT #1: The Light Bulb

First, you need a 9V battery (alkaline is best). Fold out the battery holder cutouts and snap the battery into its clip. Always remove the battery from its clip if you won't be using your Playground for a while.

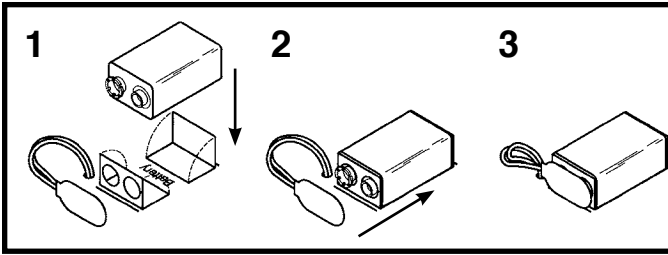

Your Electronic Playground consists of electronic parts connected to springs and mounted on a cardboard panel. You will use wires to connect these springs together to form a circuit. You are provided with several different lengths of wires, and it is usually best to use the shortest length of wire that comfortably reaches between two springs so that your wiring appears less confusing and easier to check. Notice that each spring has a number next to it. For each circuit we will tell you the spring numbers to connect in order to build the circuit. And as you build each circuit you will slowly learn more and more about electronics.

Enough talk, let's start building your first circuit. To connect a wire to a spring, bend the spring back to one side with one finger and slip the metal end of the wire into the spring; let go of the spring and it should clamp the wire firmly in place. Tug lightly on the wire to make sure you have a secure connection. And be sure the spring touches the metal portion of the wire, the colored plastic insulation doesn't count. To remove a wire, bend the spring and pull the wire away. When you have two or more wires connecting to the same spring, make sure that one wire does not come loose while you connect the others. This will be easier if you connect the wires on different sides of the spring.

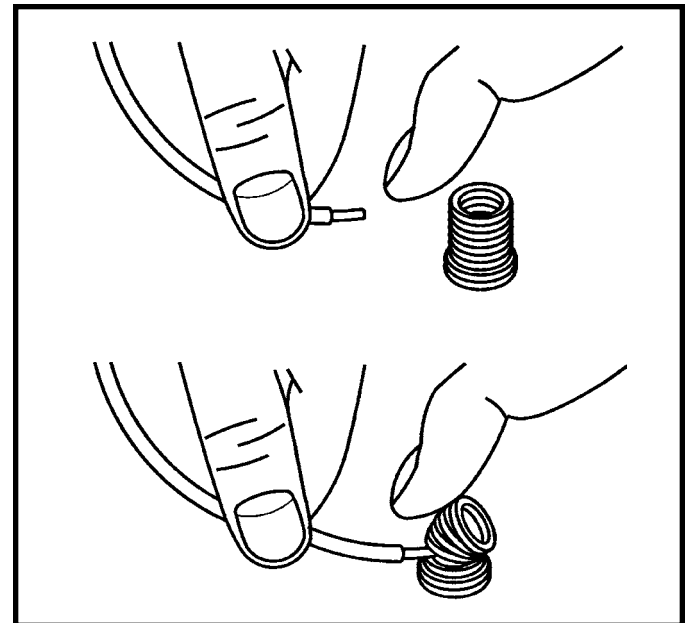

Now connect the wires for this circuit according to the list below, which we'll call the Wiring Checklist. When you're finished your wiring should look like the diagram shown here:

### Wiring Checklist:

- 27-to-56
- 55-to-45
- 44-to-3
- 4-to-26

Be sure all your wires are securely in place and not loose. Also make sure the metal in the wires is only touching the spring and wires that it is connected to, and not to any nearby springs or other wires.

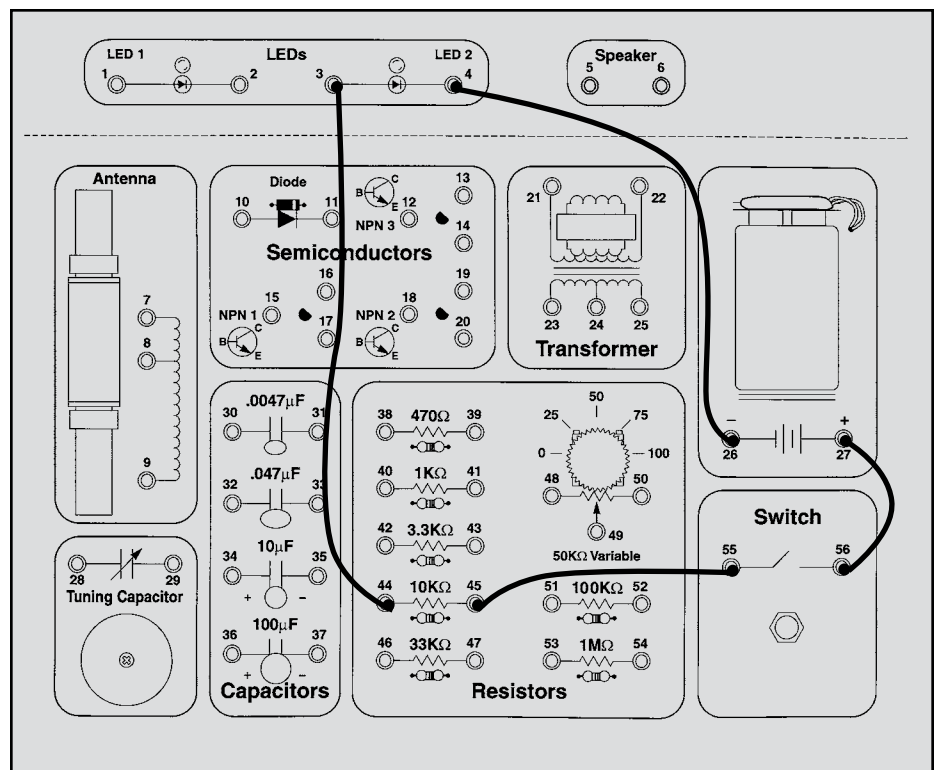



Press the switch (next to springs 55 and 56) and the **LED (light emitting diode)** lights up, and turns off when you release the switch. The LED converts electrical energy into light, like the light bulbs in your home. You can also think of an LED as being like a simple water meter, since as the electric current increases in a wire the LED becomes brighter. It is shown here, with its symbol.

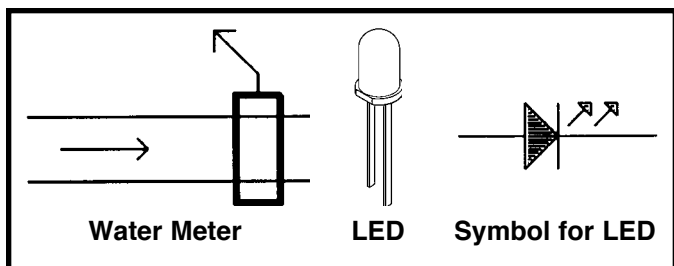

Now you will see how changing the resistance in the circuit increases the current through it. Press the switch again and observe the brightness of the LED. Now remove the wires from the 10KΩ resistor (springs 44 and 45) and connect them to the 1KΩ resistor (springs 40 and 41). Press the switch. The LED is brighter now, do you understand why? We are using a lower resistance (less rocks), so there is more electrical current flowing (more water flows), so the LED is brighter. Now replace the 1KΩ resistor with the 100KΩ resistor (springs 51 and 52) and press the switch again. The LED will be on but will be very dim (this will be easier to see if you wrap your hand near the LED to keep the room lights from shining on it).

Well done! You've just built YOUR first electronic circuit!

Take a look at the water diagram that follows. It shows the flow of water from the pump through the faucet, the small pipe, the water meter, the large pipes, and back to the pump. Now compare it to the electrical diagram next to it, called a **schematic**. Schematics are the "maps" for electronic circuits and are used by all electronic designers and technicians on everything from your Electronic Playground to the most advanced supercomputers. They show the flow of electricity from the battery through the switch, the resistor, the LED, the wires, and back to the battery. They also use the symbols for the battery, switch, resistor, and LED that we talked about. Notice how small and simple the schematic looks compared to the water diagram; that is why we use it.

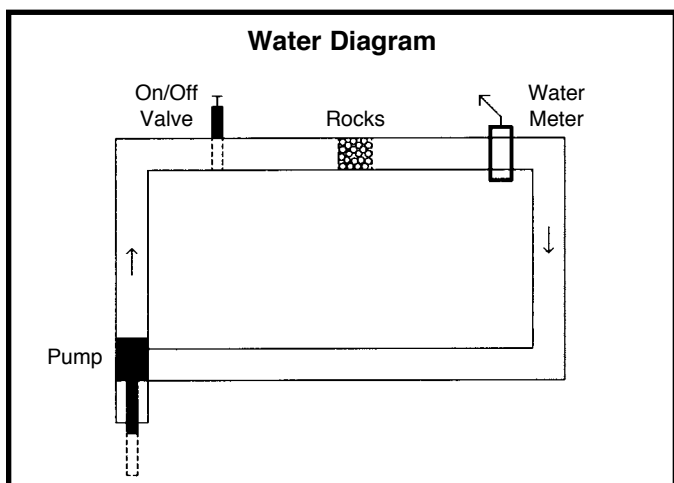
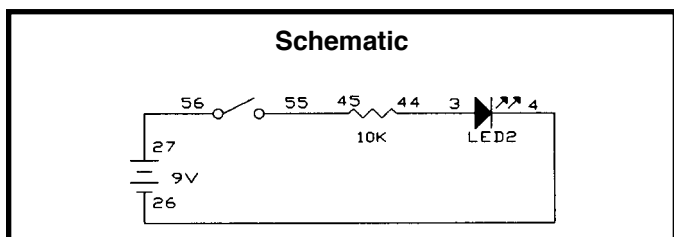

# MORE ABOUT RESISTORS

Ohm's Law: You just observed that when you have less resistance in the circuit, more current flows (making the LED brighter). The relationship between voltage, current, and resistance is known as **Ohm's Law** (after George Ohm who discovered it in 1828):

$$\text{Current} = \frac{\text{Voltage}}{\text{Resistance}}$$

Resistance: Just what is Resistance? Take your hands and rub them together very fast. Your hands should feel warm. The **friction** between your hands converts your effort into heat. Resistance is the electrical friction between an electric current and the material it is flowing through; it is the loss of energy from electrons as they move between atoms of the material. Resistors are made using carbon and can be constructed with different resistive values, such as the seven parts included in your Electronic Playground. If a large amount of current is passed through a resistor then it will become warm due to the electrical friction. Light bulbs use a small piece of a highly resistive material called tungsten. Enough current is passed through this tungsten to heat it until it glows white hot, producing light. Metal wires have some electrical resistance, but it is very low (less than 1Ω per foot) and can be ignored in almost all circuits. Materials such as metals which have low resistance are called conductors. Materials such as paper, plastic, and air have extremely high values of resistance and are called insulators.

Resistor Color Code: You may have seen the colored bands on the resistors and may be wondering what they mean. They are the method for marking the value of resistance on the part. The first ring represents the first digit of the resistor's value. The second ring represents the second digit of the resistor's value. The third ring tells you the power of ten to multiply by, (or the number of zeros to add). The final and fourth ring represents the construction tolerance. Most resistors have a gold band for a 5% tolerance. This means the value of the resistor is guaranteed to be within 5% of the value marked. The colors below are used to represent the numbers 0 through 9.

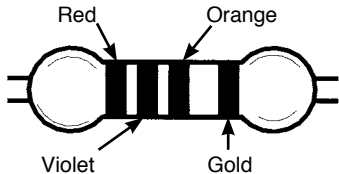
COLOR	VALUE	Example of Color Code
Black	0	 <p>Red                      Orange</p> <p>Violet                      Gold</p> <p><math>27 \times 10^3 = 27,000 \Omega</math>, with 5% Tolerance</p>
Brown	1	
Red	2	
Orange	3	
Yellow	4	
Green	5	
Blue	6	
Violet	7	
Gray	8	
White	9	

Use the color code to check the values of the seven resistors included in your Electronic Playground. (The values are marked next to them on the box). They are all 5% tolerance.

The Variable Resistor: We talked about how a switch is used to turn the electricity on and off just like a valve is used to turn the water on and off. But there are many times when you want some water but don't need all that the pipe can deliver, so you control the water by adjusting an opening in the pipe with a faucet. Unfortunately, you can't adjust the thickness of an already thin wire. But you could also control the water flow by forcing the water through an adjustable length of rocks, as in the rock arm shown below.

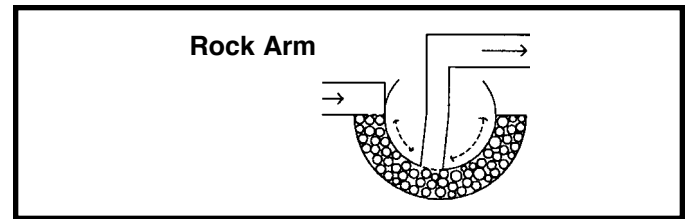

In electronics we use a variable resistor. This is a normal resistor (50KΩ in your Playground) with an additional arm contact that can move along the resistive material and tap off the desired resistance.

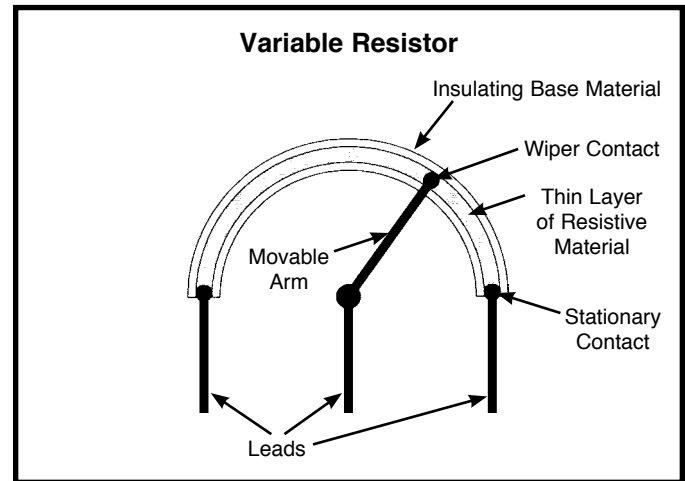

There is a scale printed next to the dial on the variable resistor which shows the percentage of the total resistance that is between springs 49 and 50. The remaining resistance will be between springs 48 and 49. The resistance between springs 48 and 50 will always be 50KΩ, the total resistance.

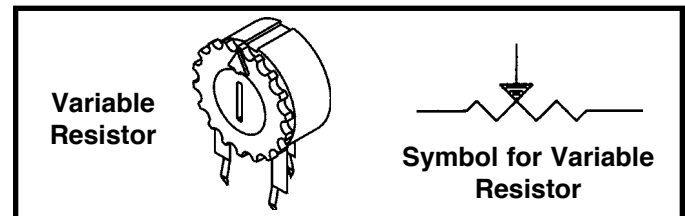

Now let's demonstrate how this works.

## EXPERIMENT #2: The Brightness Control

Connect the wires according to the Wiring Checklist. Press the switch and the LED lights up. Now hold the switch closed with one hand and turn the dial on the variable resistor with the other. When the dial setting is high, the resistance in the circuit is low and the LED is bright because a large current flows. As you turn the dial lower the resistance increases and the LED will become dim, just as forcing the water through a section of rocks would slow the water flow and lower the reading on your water meter.

You may be wondering what the 1K $\Omega$  resistor is doing in the circuit. If you set the dial on the variable resistor for minimum resistance (0 $\Omega$ ) then Ohm's Law tells us the current will be very large - and it might damage the LED (think of this as a very powerful water pump overloading a water meter). So the 1K $\Omega$  was put in to limit the current while having little effect on the brightness of the LED.

Now remove the wire from spring 48 and connect it to spring 50 (use a longer wire if necessary). Do you know what will happen now? Close the switch and you will see that as you turn the dial from 0 to 100 the LED goes from very bright to very dim, because you are increasing the resistance between springs 49 and 50.

Now remove the wire from spring 49 and connect it to spring 48. What do you think will happen? Close the switch and turn the dial. The LED is dim and turning the resistor dial won't make it any brighter. As discussed above, the resistance between 48 and 50 is always 50K $\Omega$  and the part acts just like one of the other resistors in your Electronic Playground.

Variable resistors like this one are used in the light dimmers you may have in your house, and are also used to control the volume in your radio, your TV, and many electronic devices.

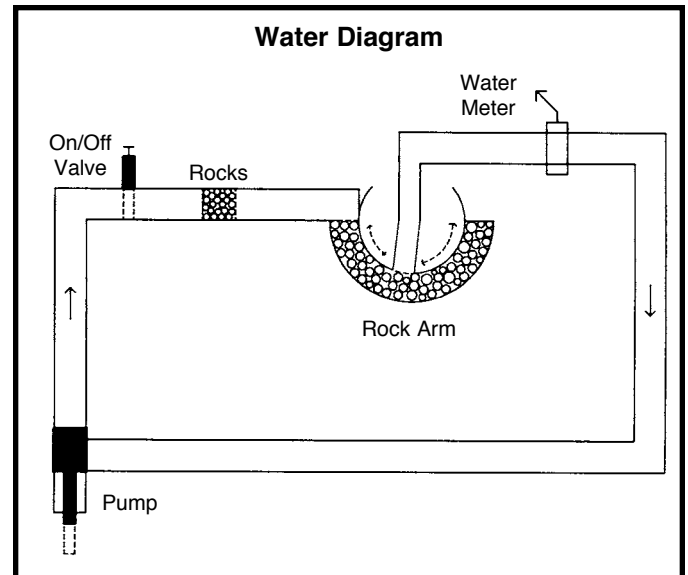
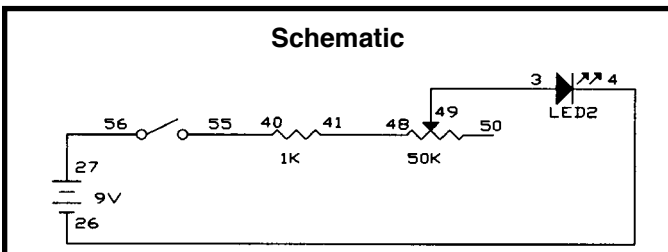

### Wiring Checklist:

- 27-to-56
- 55-to-40
- 41-to-48
- 49-to-3
- 4-to-26

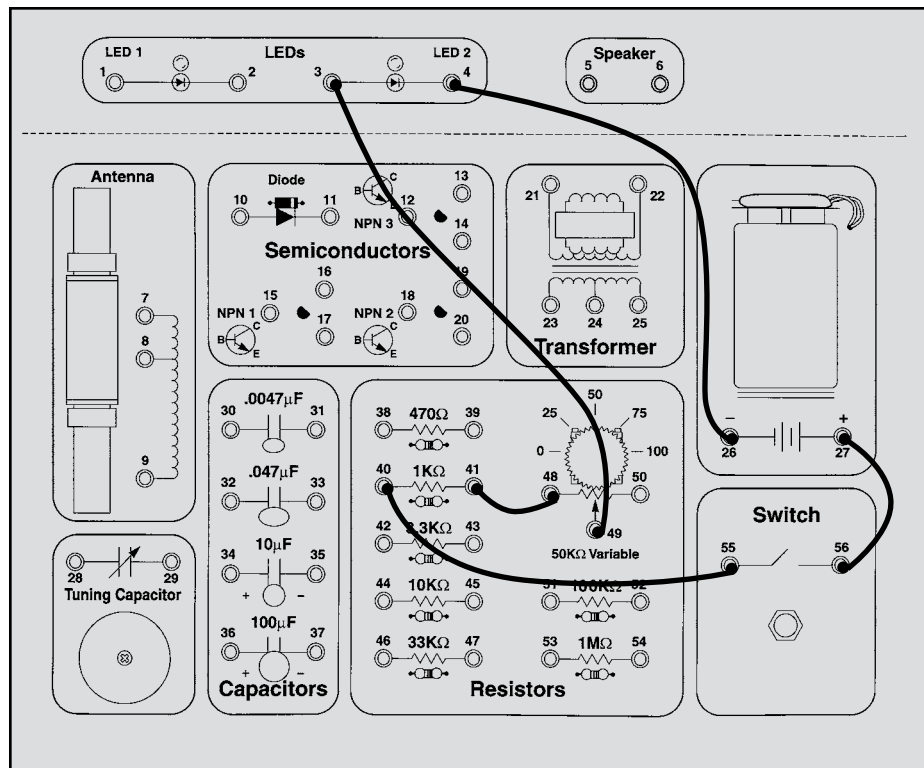

## EXPERIMENT #3: Resistors in Series

Connect the wires according to the Wiring Checklist and press the switch. The LED is on but is very dim (this will be easier to see if you wrap your hand near the LED to keep the room lights from shining on it). Take a look at the schematic. There is a low  $3.3\text{K}\Omega$  resistor and a high  $100\text{K}\Omega$  resistor in **series** (one after another). Since the LED is dimly lit, we know that the larger  $100\text{K}\Omega$  must be controlling the current. You can think of this as where two sections of the pipe are filled with rock, if one section is much longer than the other then it controls the water flow. If you had several rock sections of different lengths then it is easy to see that these would add together as if they were one longer section. The total length is what matters, not how many sections the rock is split into. The same is true in electronics - **resistors in series add together** to increase the total resistance for the circuit. (In our circuit the  $3.3\text{K}\Omega$  and  $100\text{K}\Omega$  resistors add up to  $103.3\text{K}\Omega$ ).

To demonstrate this, disconnect the wires from the  $100\text{K}\Omega$  resistor and connect them instead to the  $10\text{K}\Omega$ , press the switch; the LED should be easy to see now (total resistance is now only  $13.3\text{K}\Omega$ ). Next, disconnect the  $10\text{K}\Omega$  resistor and connect the  $1\text{K}\Omega$  in its place. The LED is now bright, but not as bright as when you used the  $1\text{K}\Omega$  in Experiment #1. Why? Because now the  $3.3\text{K}\Omega$  is the larger resistor (total resistance is  $4.3\text{K}\Omega$ ).

Also, in Experiment #2 you saw how the  $1\text{K}\Omega$  resistor would dominate the circuit when the variable resistor was set for  $0\Omega$  and how the variable resistor would dominate when set for  $50\text{K}\Omega$ .

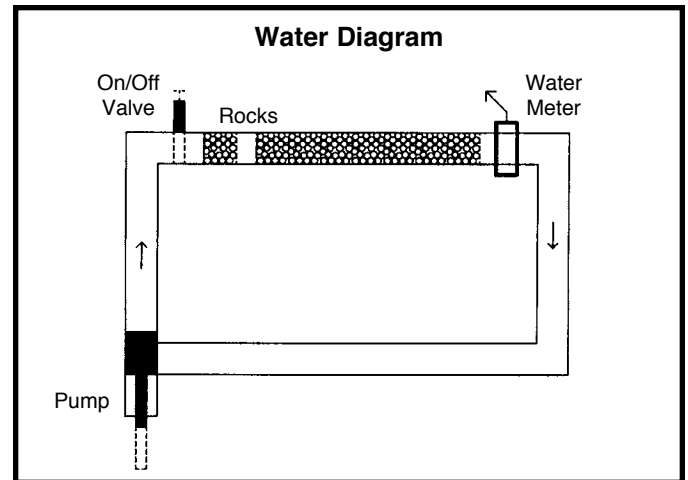
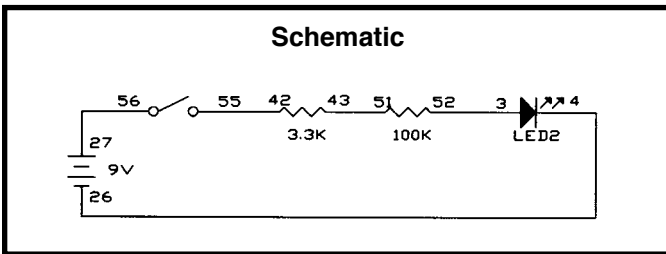

### Wiring Checklist:

- 27-to-56
- 55-to-42
- 43-to-51
- 52-to-3
- 4-to-26

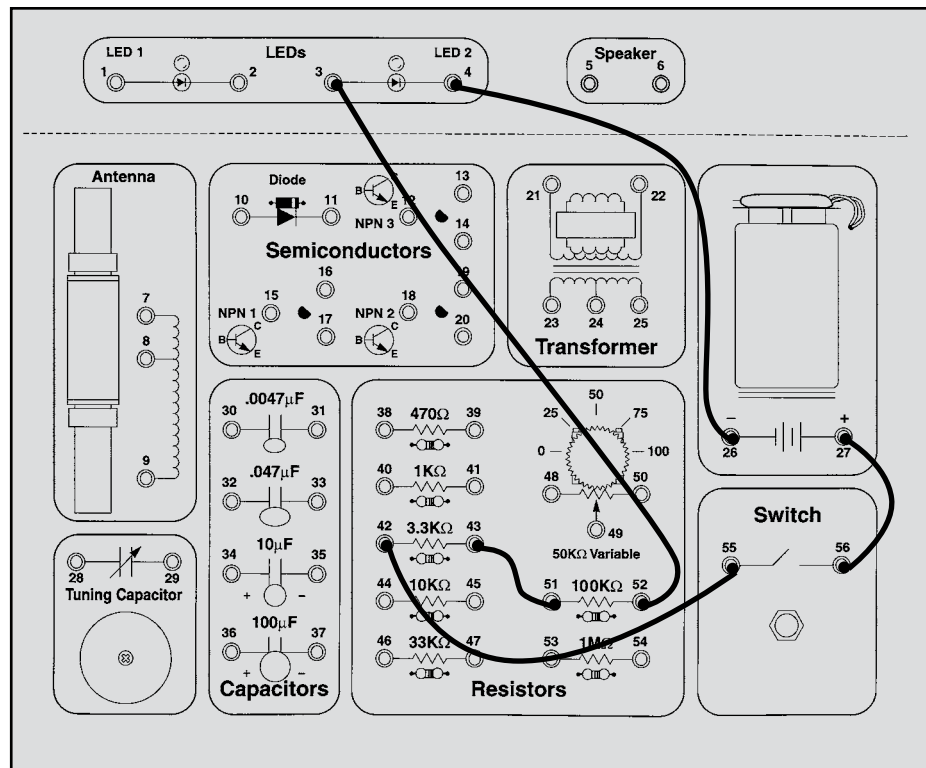

# EXPERIMENT #4: Parallel Pipes

Connect the wires according to the Wiring Checklist. Take a look at the schematic. There is a low 3.3KΩ resistor and a high 100KΩ resistor in **parallel** (connected between the same points in the circuit). How bright do you think the LED will be? Press the switch and see if you are right. The LED is bright, so most of the current must be flowing through the smaller 3.3KΩ resistor. This makes perfect sense when we look at the water diagram, with most of the water flowing through the pipe with less rocks. In general, **the more water pipes (or resistors) there are in parallel, the lower the total resistance is** and the more water (or current) will flow. The relationship is more complicated than for resistors in series and is given here for advanced students:

$$R_{\text{Parallel}} = \frac{R_1 \times R_2}{R_1 + R_2}$$

For two 10KΩ resistors in parallel, the result would be 5KΩ. The 3.3KΩ and 100KΩ in parallel in our circuit now give the same LED brightness as a single 3.2KΩ resistor.

To demonstrate this, disconnect the wires from the 100KΩ resistor and connect them to the 10KΩ; press the switch and the LED should be just as bright. The total resistance is now only 2.5KΩ, but your eyes probably won't notice much difference in LED brightness. Now disconnect the wires from the 10KΩ and connect them to the 1KΩ; press the switch. The total resistance is now only 770Ω, so the LED should now be much brighter.

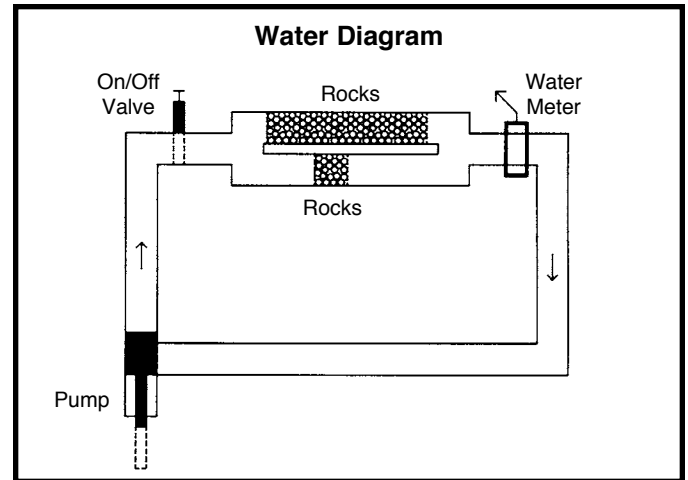
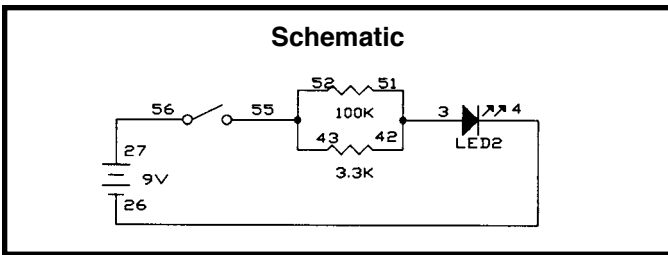

### Wiring Checklist:

- 27-to-56
- 55-to-52-to-43 (this will take 2 wires)
- 51-to-42-to-3 (2 wires)
- 4-to-26

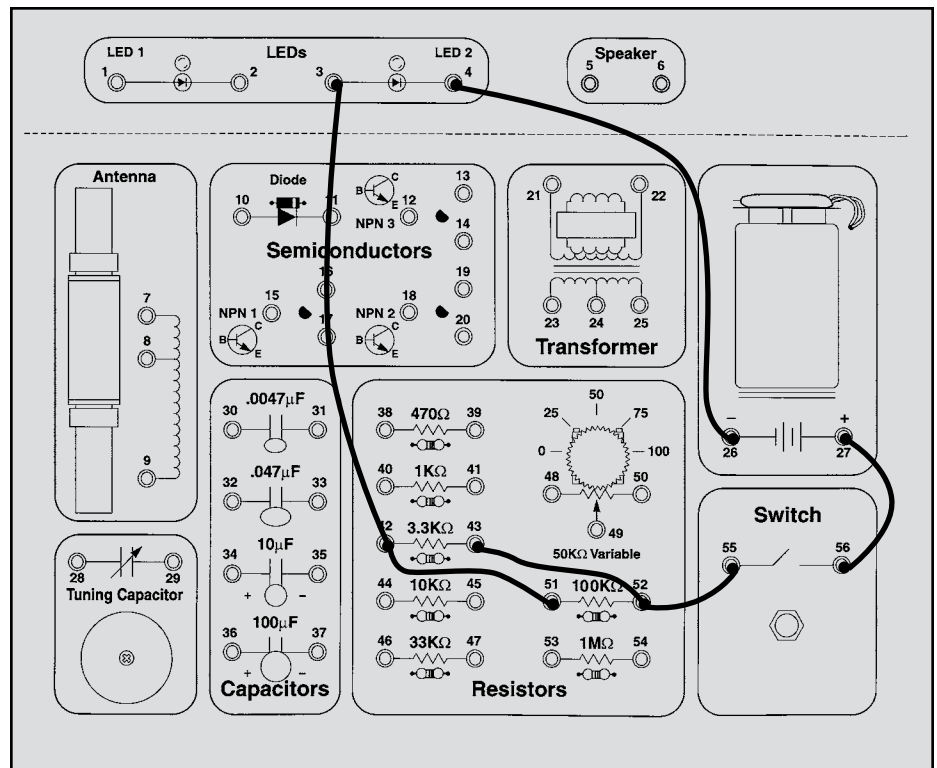

There is an even easier way to explain this:

## EXPERIMENT #4B: Comparison of Parallel Currents

Since we have two resistors in parallel and a second LED that is not being used, let's modify the circuit to match the schematic below. It's basically the same circuit but instead of just parallel resistors there are parallel resistor-LED circuits. Disconnect the wire between 51 (the 100KΩ resistor) and 42 (the 3.3KΩ resistor) and connect it between 51 and 1 (LED1) instead (you may need a longer wire). Add a wire from 2 (LED1) to 4

(LED2). Replace the 100KΩ resistor with several values as before (such as 1KΩ, 10KΩ, and others if you wish), pressing the switch and observing the LEDs each time. The brightness of LED2 will not change, but the brightness of LED1 will depend on the resistor value you placed in series with it.

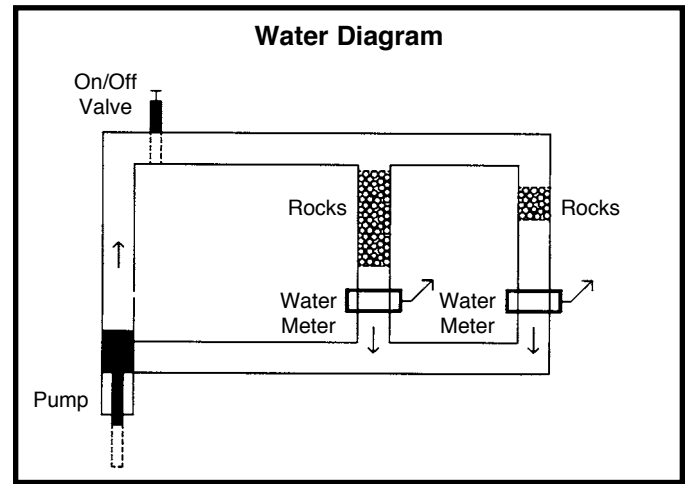
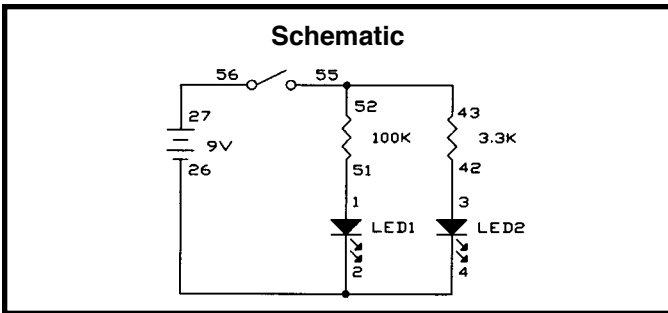

### Wiring Checklist:

- 27-to-56
- 55-to-52-to-43 (2 wires)
- 51-to-1
- 42-to-3
- 2-to-4-to-26 (2 wires)

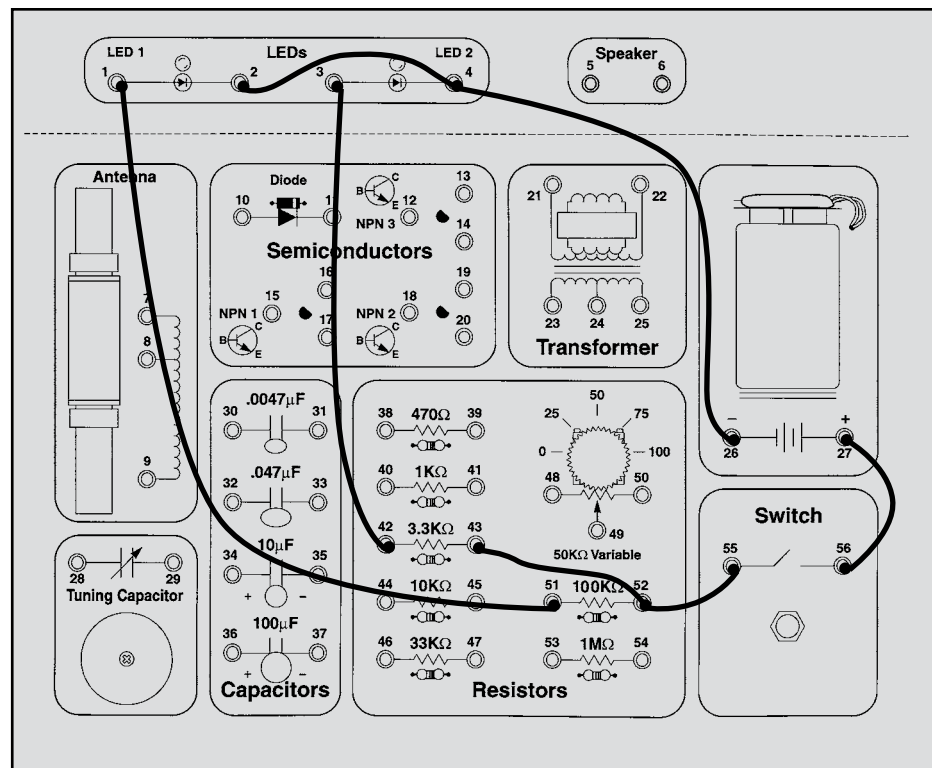

## EXPERIMENT #5: Combined Circuit

Let's combine everything we've done so far. Connect the wires according to the Wiring Checklist. Before pressing the switch, take a look at the schematic and think about what will happen as you turn the dial on the variable resistor (we'll abbreviate this to VR). Now press the switch with one hand and turn the dial with the other to see if you were right. As you turn the VR dial from right to left LED1 will go from bright to very dim and LED2 will go from visible to off.

What's happening is this: With the dial turned all the way to the right the VR is  $0\Omega$  (much smaller than the  $10K\Omega$ ) so nearly all of the current passing through the  $3.3K\Omega$  will take the VR-LED1 path and very little will take the

$10K\Omega$ -LED2 path. When the VR dial is turned to 80% the VR is  $10K\Omega$  (same as the other path) and the current flowing through the  $3.3K\Omega$  will divide equally between the two LED paths (making them equally bright). As the VR dial is turned to the left the VR becomes a  $50K\Omega$  (much larger than the  $10K\Omega$ ) and LED1 will become dim while LED2 gets brighter.

Now is a good time to take notes on how resistors work in series and in parallel. All electronic circuits are much larger combinations of series and parallel circuits such as these. It's important to understand these ideas because soon we'll apply them to capacitors and inductors!

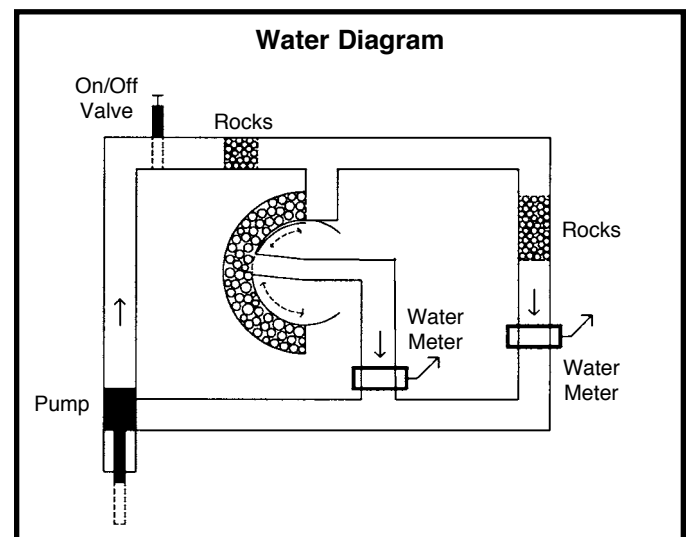
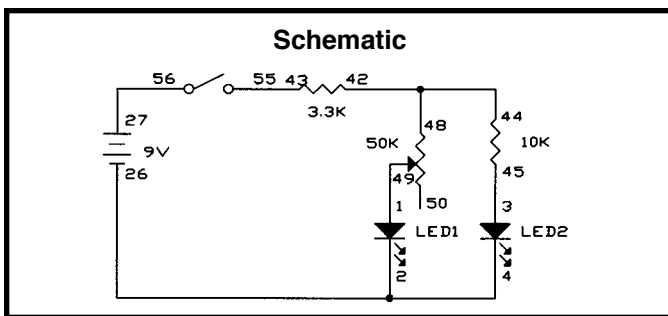

### Wiring Checklist:

- 27-to-56
- 55-to-43
- 44-to-42-to-48
- 49-to-1
- 45-to-3
- 2-to-4-to-26

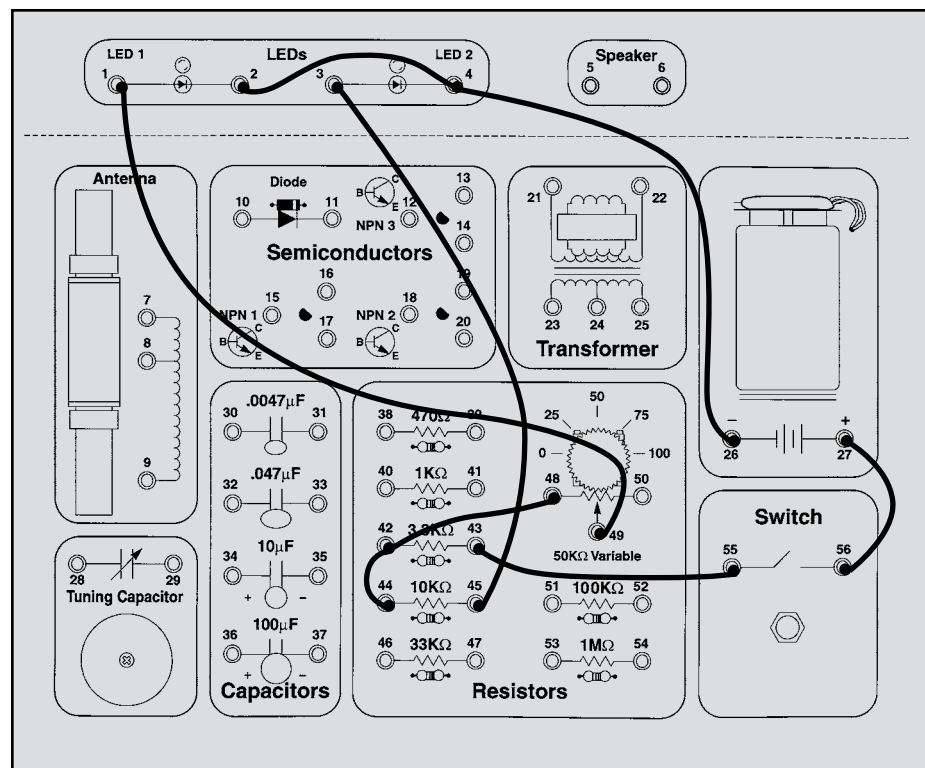

# EXPERIMENT #6: Water Detector

You've seen how electricity flows through copper wires easily and how carbon resists the flow. How well does water pass electricity? Let's find out.

Connect the wires according to the Wiring Checklist and take a look at the schematic. There isn't a switch this time, so just disconnect one of the wires if you want to turn the circuit off. Notice that the Wiring Checklist leaves 2 wires unconnected. The LED will be off initially (if you touch the two loose wires together then it will be on). Now take a small cup (make sure it isn't made of metal), fill it half way with water, and place the two unconnected wires into the water without touching each other. The LED should now be dimly lit, but the brightness could vary depending on your local water quality. You are now seeing a demonstration of how water conducts (passes) electricity. (A small cup of water like this may be

around 100KΩ, but depends on the local water quality). Try adding more water to the cup and see if the LED brightness changes (it should get brighter because we are "making the water pipe larger"). Since the LED only lights when it is in water now, you could use this circuit as a water detector!

Now adjust the amount of water so that the LED is dimly lit. Now, watching the LED brightness, add some table salt to the water and stir to dissolve the salt. The LED should become brighter because water has a lower electrical resistance when salt is dissolved in it. Looking at the water pipe diagram, you can think of this as a strong cleaner dissolving paintballs that are mixed in with the rocks. You could even use this circuit to detect salt water like in the ocean!

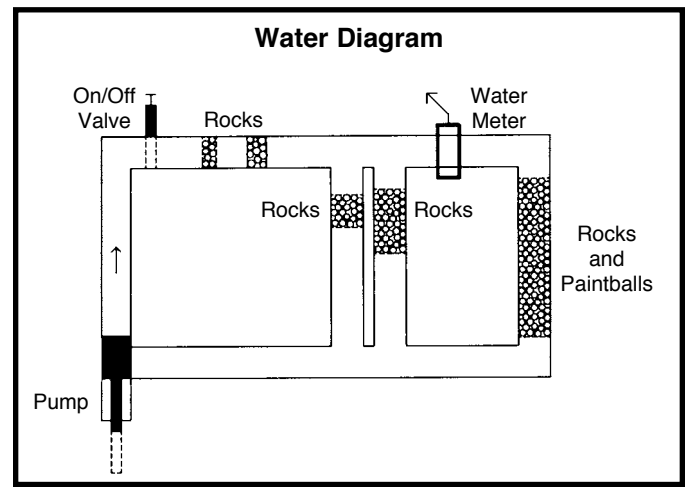
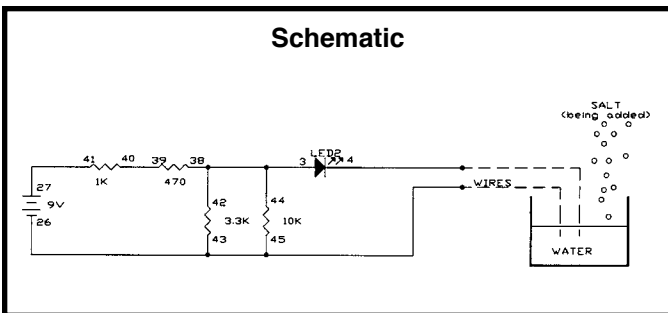

### Wiring Checklist:

- 27-to-41
- 40-to-39
- 44-to-42-to-38-to-3
- 4-to-unconnected (use a long wire)
- 26-to-45-to-43-to-unconnected (the unconnected wire should be long)

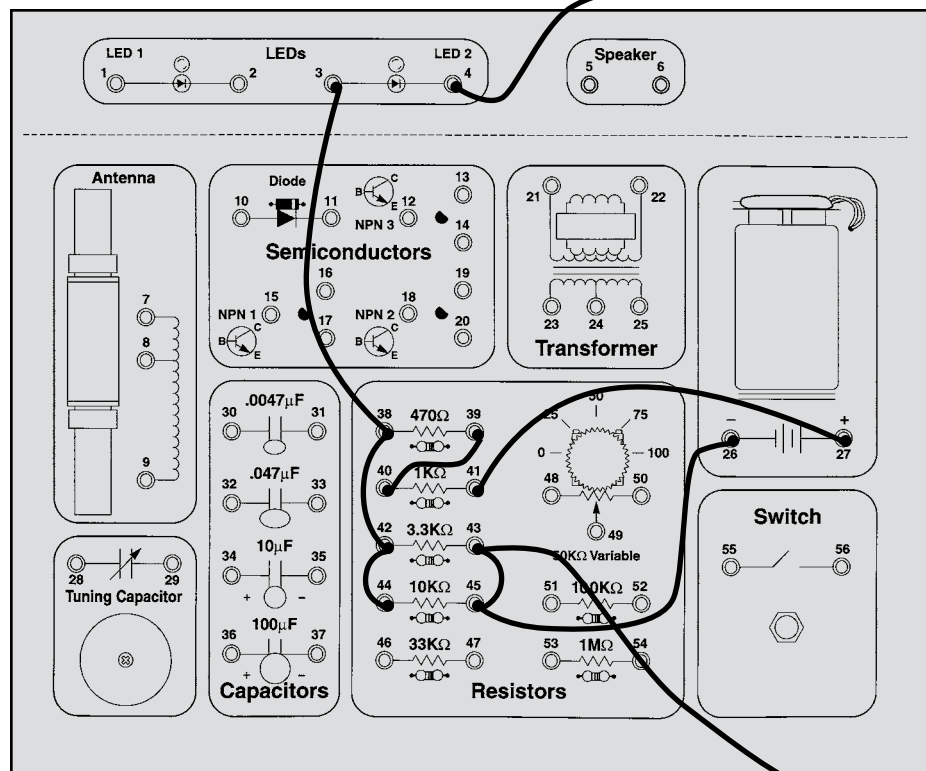

Long Wire to Water

Long Wire to Water



## INTRODUCTION TO CAPACITORS

**Capacitors:** Capacitors are electrical components that can store electrical pressure (voltage) for periods of time. When a capacitor has a difference in voltage (electrical pressure) across it, it is said to be charged. A capacitor is charged by having a one-way current flow through it for a short period of time. It can be discharged by letting a current flow in the opposite direction out of the capacitor. In the water pipe analogy, you may think of the capacitor as a water pipe that has a strong rubber diaphragm sealing off each side of the pipe as shown below:

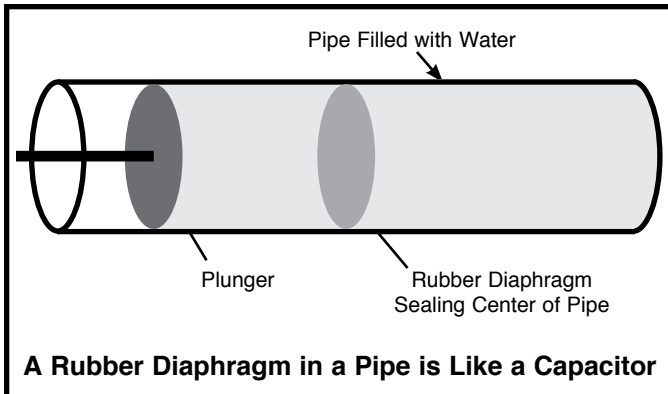

If the pipe had a plunger on one end (or a pump elsewhere in the piping circuit), as shown above, and the plunger was pushed toward the diaphragm, the water in the pipe would force the rubber to stretch out until the force of the rubber pushing back on the water was equal to the force of the plunger. You could say the pipe is charged and ready to push the plunger back. In fact if the plunger is released it will move back to its original position. The pipe will then be discharged or with no pressure on the diaphragm.

Capacitors act the same as the pipe just described. When a voltage (electrical pressure) is placed on one side with respect to the other, electrical charge "piles up" on one side of the capacitor (on the capacitor "plates") until the voltage pushing back equals the voltage applied. The capacitor is then charged to that voltage. If the charging voltage was then decreased the capacitor would discharge. If both sides of the capacitor were connected together with a wire then the capacitor would rapidly discharge and the voltage across it would become zero (no charge).

What would happen if the plunger in the drawing above was wiggled in and out many times each second? The water in the pipe would be pushed by the diaphragm and then sucked back by the diaphragm. Since the movement of the water (current) is back and forth (alternating) it is called an **alternating current** or **AC**. The capacitor will therefore pass an alternating current with little resistance. When the push on the plunger was only toward the diaphragm, the water on the other side of the diaphragm moved just enough to charge the pipe (a transient or temporary current). Just as the pipe blocked a direct push, a capacitor blocks a **direct current (DC)**.

Current from a battery is an example of direct current. An example of alternating current is the 60 cycle (60 wiggles per second) current from the electrical outlets in the walls of your house.

**Construction of Capacitors:** If the rubber diaphragm is made very soft it will stretch out and hold a lot of water but will break easily (large capacitance but low working voltage). If the rubber is made very stiff it will not stretch far but will be able to withstand higher pressure (low capacitance but high working voltage). By making the pipe larger and keeping the rubber stiff we can achieve a device that holds a lot of water and withstands high pressure (high capacitance, high working voltage, large size). So the pipe size is determined by its capacity to hold water and the amount of pressure it can handle. These three types of water pipes are shown below:

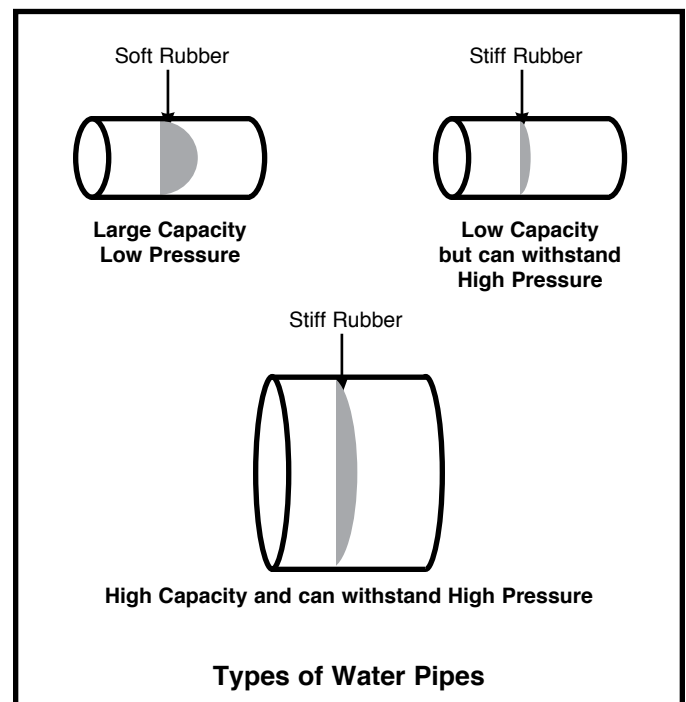

Similarly, capacitors are described by their capacity for holding electric charge, called their **Capacitance**, and their ability to withstand electric pressure (voltage) without damage. Although there are many different types of capacitors made using many different materials, their basic construction is the same. The wires (leads) connect to two or more metal plates that are separated by high resistance materials called **dielectrics**.

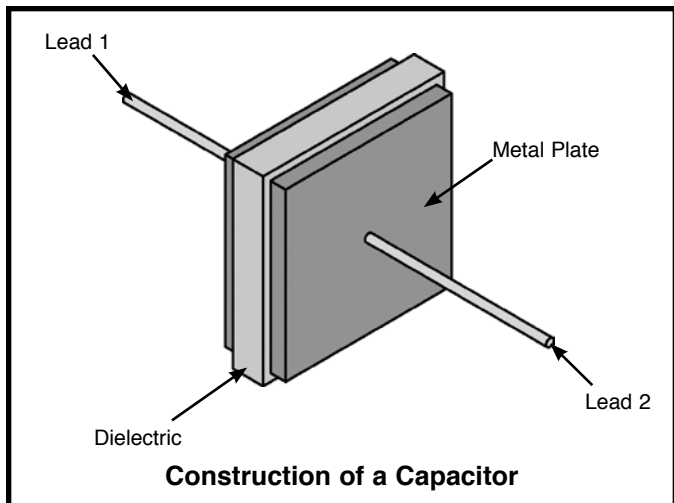

The dielectric is the material that holds the electric charge (pressure), just like the rubber diaphragm holds the water pressure. Some dielectrics may be thought of as stiff rubber, and some as soft rubber. The capacitance and working voltage of the capacitor is controlled by varying the number and size of metal-dielectric layers, the thickness of the dielectric layers, and the type of dielectric material used.

Capacitance is expressed in **farads** (F, named after Michael Faraday whose work in electromagnetic induction led to the development of today's electric motors and generators), or more commonly in microfarads ( $\mu\text{F}$ , millionths of a farad) or picofarads (pF, millionths of a microfarad). Almost all capacitors used in electronics vary from 1pF to 1000 $\mu\text{F}$ .

Your Electronic Playground includes two electrolytic (10 $\mu\text{F}$  and 100 $\mu\text{F}$ ) and two disc (.0047 $\mu\text{F}$  and .047 $\mu\text{F}$ ) capacitors. (Mylar capacitors may have been substituted for the disc ones, their construction and performance is similar). Electrolytic capacitors (usually referred to as lytics) are high capacitance and are used mostly in power supply or low frequency circuits. Their capacitance and voltage are usually clearly marked on them. Note that these parts have "+" and "-" **polarity** (orientation) markings, the lead marked "+" should always be connected to a higher voltage than the "-" lead (all of your Wiring Checklists account for this). Disc capacitors are low capacitance and are used mostly in radio or high frequency applications. They don't have voltage or polarity markings (they can be hooked up either way). Capacitors have symbols as follows:

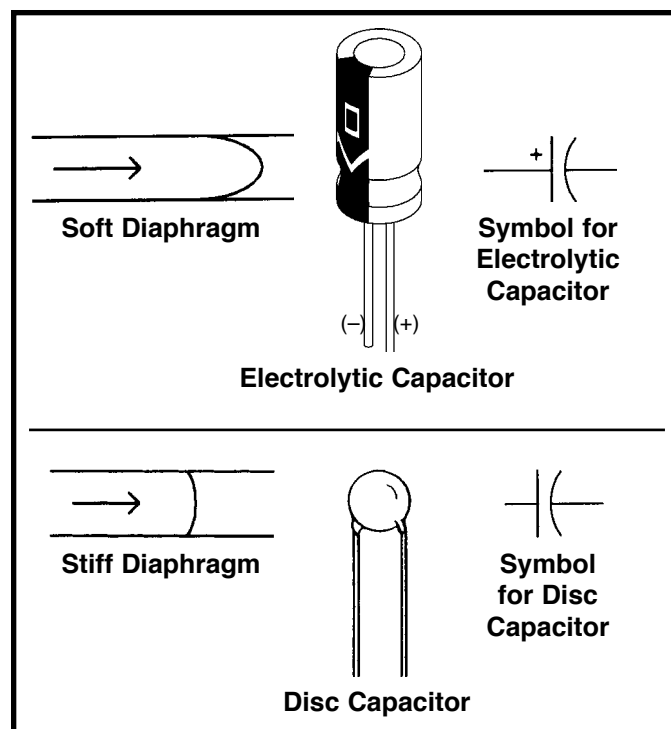

## EXPERIMENT #7: Slow Light Bulb

Connect the wires according to the Wiring Checklist and press the switch several times. You can see it takes time to charge and discharge the large capacitor because the LED lights up and goes dim slowly. Replace the 3.3K $\Omega$  resistor with the 1K $\Omega$  resistor; now the charge time is faster but the discharge time is the same. Do you know why? When the switch is closed the battery charges the capacitor through the 1K $\Omega$  resistor and when the switch is opened the capacitor discharges through the 10K $\Omega$ , which has remained the same. Now replace the 100 $\mu$ F capacitor with the 10 $\mu$ F. Both the charge and discharge

times are now faster since there is less capacitance to charge up. If you like you may experiment with different resistors in place of the 1K $\Omega$  and 10K $\Omega$ . If you observe the LED carefully, you might start to suspect the relationship between the component values and the charging and discharging times - **the charge/discharge times are proportional to both the capacitance and the resistance in the charge/discharge path!**

A simple circuit like this is used to slowly light or darken a room, such as a movie theater.

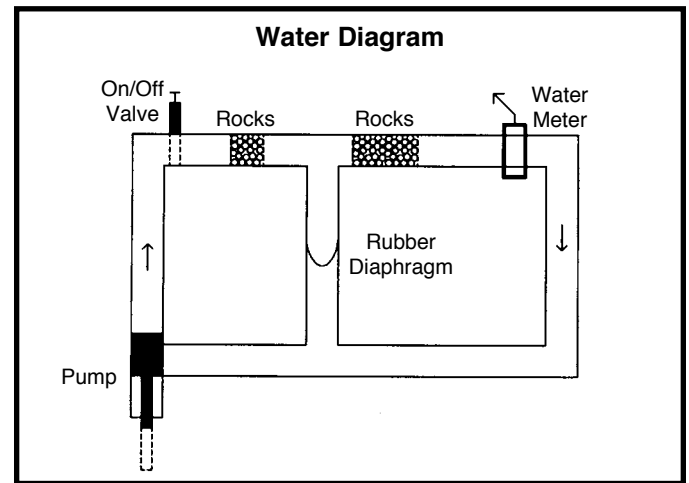
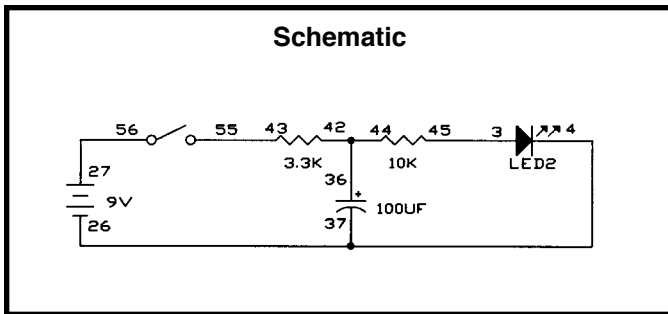

### Wiring Checklist:

- 27-to-56
- 55-to-43
- 36-to-44-to-42
- 45-to-3
- 37-to-26-to-4

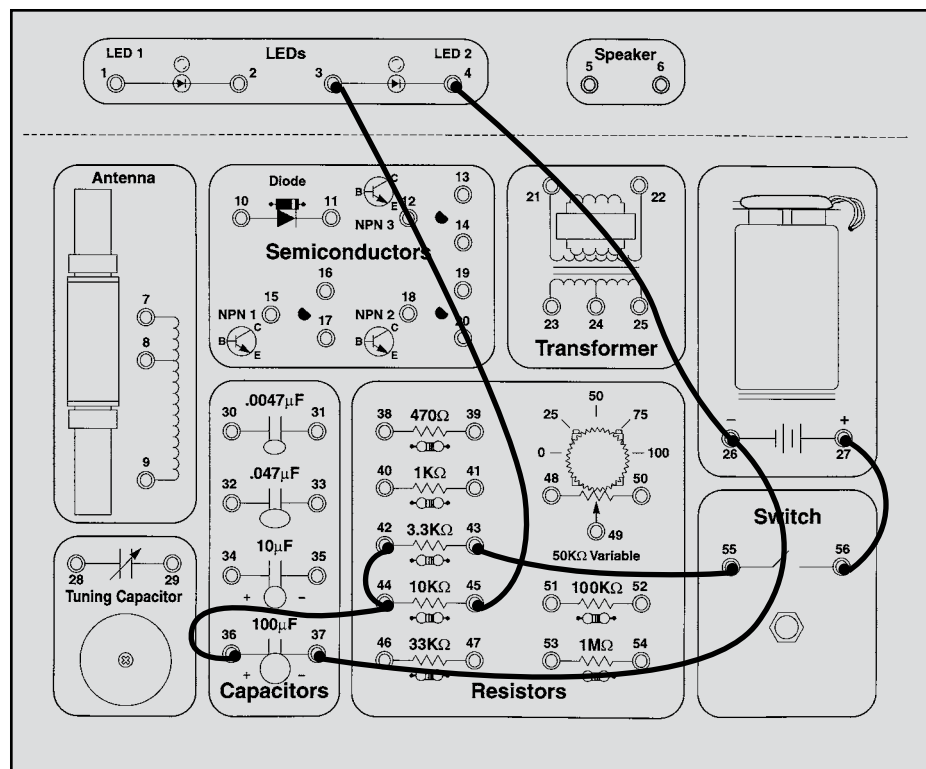

## EXPERIMENT #8: Small Dominates Large - Capacitors in Series

Take a look at the schematic, it is almost the same circuit as the last experiment except that now there are two capacitors in series. What do you think will happen? Connect the wires according to the Wiring Checklist and press the switch several times to see if you are right.

Looking at the water diagram and the name of this experiment should have made it clear - the smaller  $10\mu\text{F}$  will dominate (control) the response since it will take less time to charge up. As with resistors, you could change the order of the two capacitors and would still get the same results (try this if you like). Notice that while resistors in

series add together to make a larger circuit resistance, capacitors in series combine to make a smaller circuit capacitance. Actually, capacitors in series combine the same way resistors in parallel combine (using the same mathematical relationship given in Experiment 4). For this experiment,  $10\mu\text{F}$  and  $100\mu\text{F}$  in series perform the same as a single  $9.1\mu\text{F}$ .

In terms of our water pipe analogy, you could think of capacitors in series as adding together the stiffness of their rubber diaphragms.

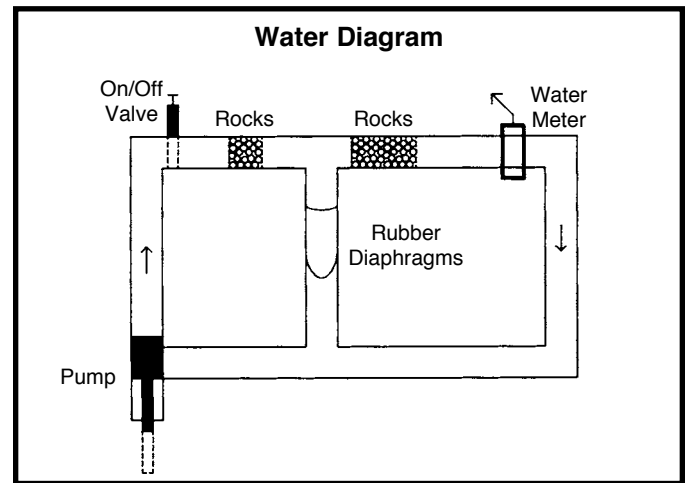
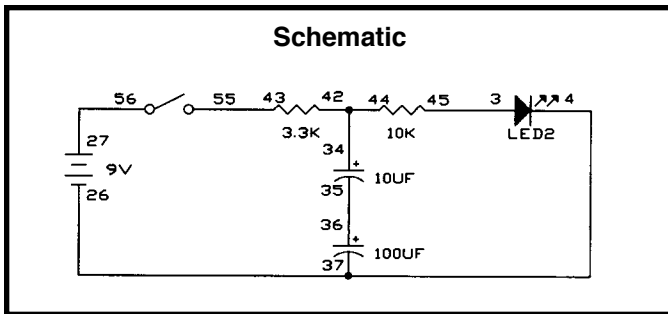

### Wiring Checklist:

- 27-to-56
- 55-to-43
- 34-to-44-to-42
- 45-to-3
- 37-to-26-to-4
- 35-to-36

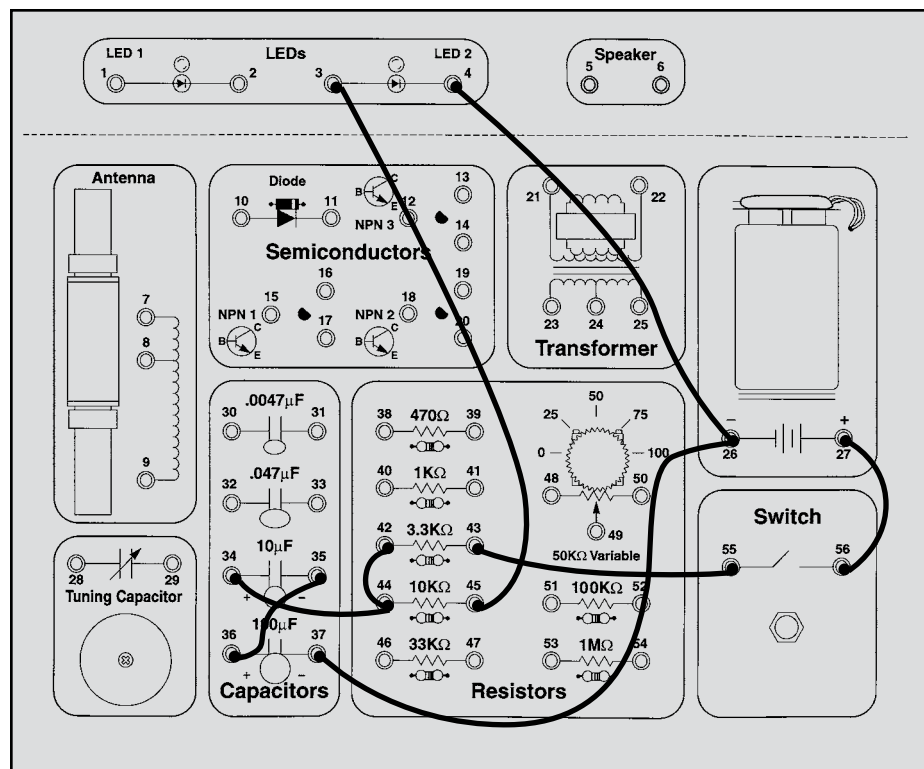

## EXPERIMENT #9: Large Dominates Small - Capacitors in Parallel

Now you have capacitors in parallel, and you can probably predict what will happen. If not, just think about the last experiment and about how resistors in parallel combine, or think in terms of the water diagram again. Connect the wires according to the Wiring Checklist and press the switch several times to see.

Capacitors in parallel add together just like resistors in series, so here  $10\mu\text{F} + 100\mu\text{F} = 110\mu\text{F}$  total circuit capacitance. In the water diagram, we are stretching both

rubber diaphragms at the same time so it will take longer than to stretch either one by itself. If you like you may experiment with different resistor values as you did in experiment #7. Although you do have two disc capacitors and a variable capacitor (which will be discussed later) there is no point in experimenting with them now, their capacitance values are so small that they would act as an open switch in any of the circuits discussed so far.

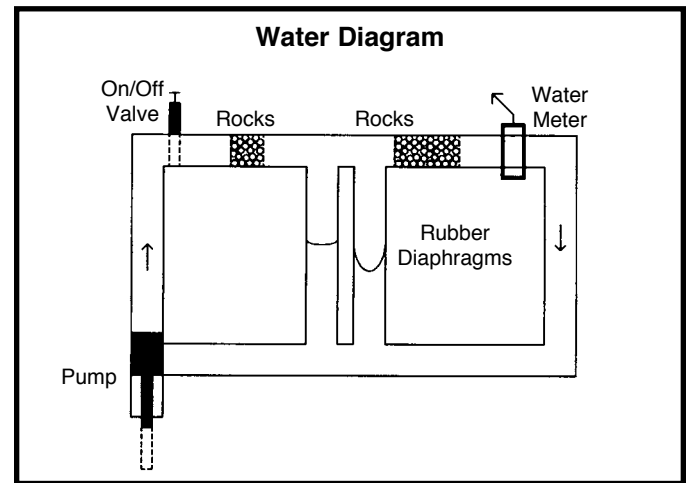
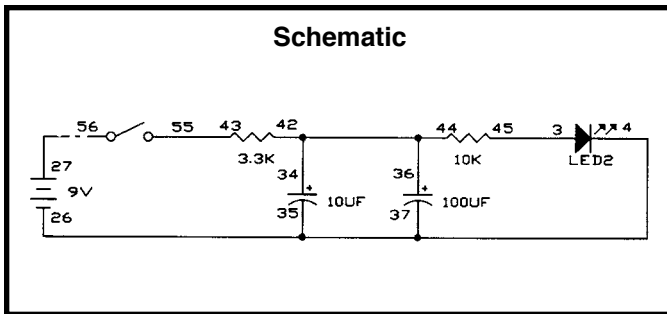

### Wiring Checklist:

- 27-to-56
- 55-to-43
- 36-to-34-to-44-to-42
- 45-to-3
- 37-to-35-to-26-to-4

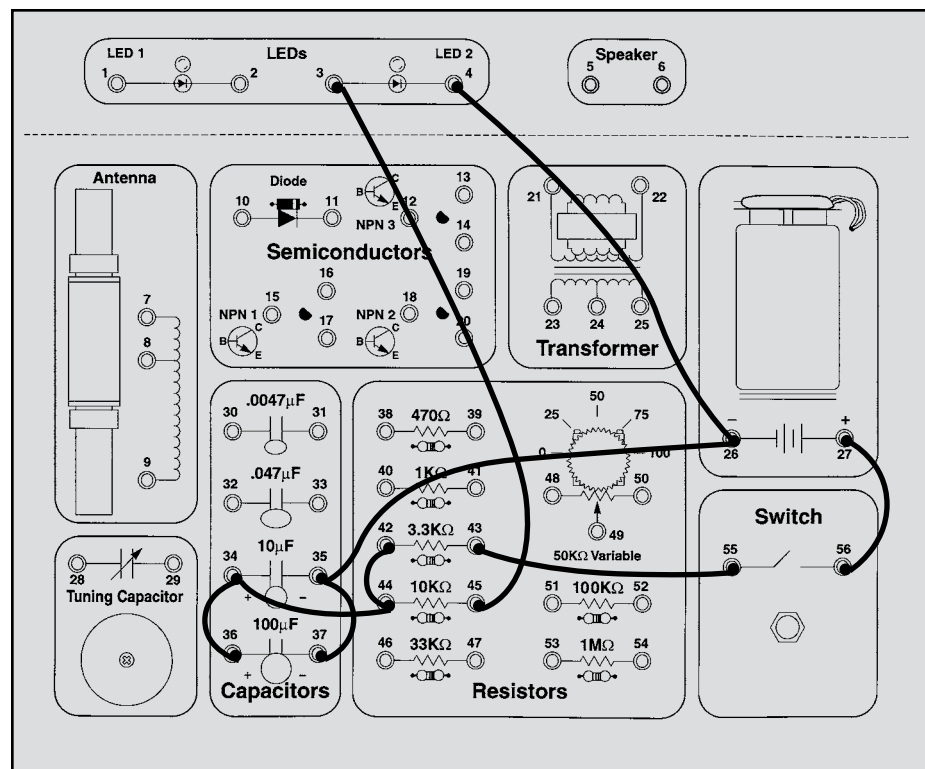

# EXPERIMENT #10: Make Your Own Battery

Connect the wires according to the Wiring Checklist, noting that there is no switch and a long wire with one end connected to the 100 $\mu$ F capacitor and the other end unconnected. At this time no current will flow because nothing is connected to the battery. Now hold the loose wire and touch it to battery spring 27 and then remove it, the battery will instantly charge the capacitor since there is no resistance (actually there is some internal resistance in the battery and some in the wires but these are very small). The capacitor is now charged and is storing the electricity it received from the battery. It will remain charged as long as the loose wire is kept away from any metal. Now touch the loose wire to spring 43 on the 3.3K $\Omega$  resistor and watch the LED. It will initially be very bright but diminishes quickly as the capacitor discharges. Repeat charging and discharging the capacitor several times. You can also discharge the 100 $\mu$ F in small bursts by only briefly touching the 3.3K $\Omega$ . If you like you can experiment with using different values in place of the

3.3K $\Omega$ ; lower values will make the LED brighter but it will dim faster while with higher resistor values the LED won't be as bright but it will stay on longer. You can also put a resistor in series with the battery when you charge the capacitor, then it will take time to fully charge the capacitor. What do you think would happen if you used a smaller capacitor value?

When the capacitor is charged up it is storing electricity which could be used elsewhere at a later time - it is like a battery! However, an electrolytic capacitor is not a very efficient battery. Storing electric charge between the plates of a capacitor uses much more space than storing the same amount of charge chemically within a battery - compare how long the 100 $\mu$ F lit the LED above with how your 9V battery runs all of your experiments!

Now is a good time to take notes for yourself on how capacitors work, since next we introduce the diode.

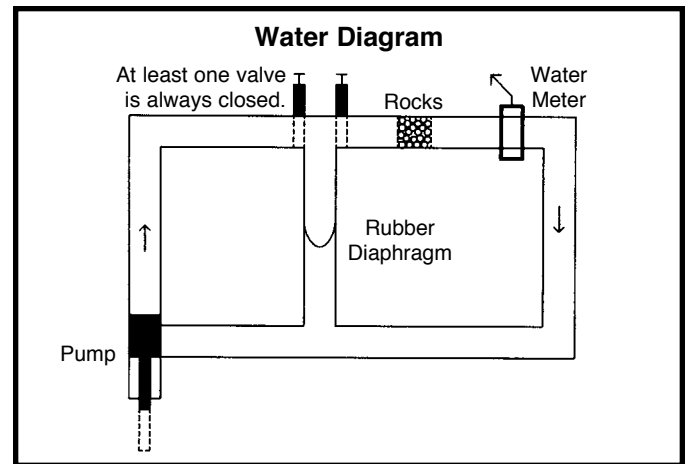
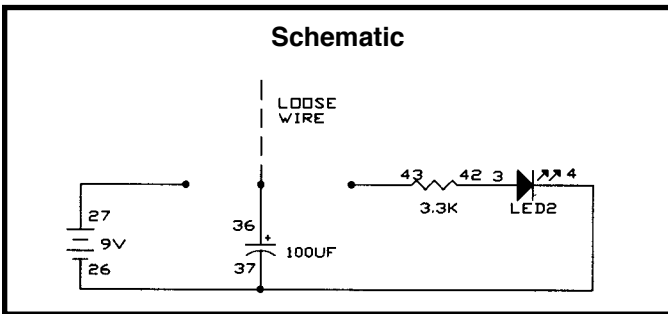

### Wiring Checklist:

- 37-to-26-to-4
- 42-to-3
- 36-to-unconnected (use a long wire)

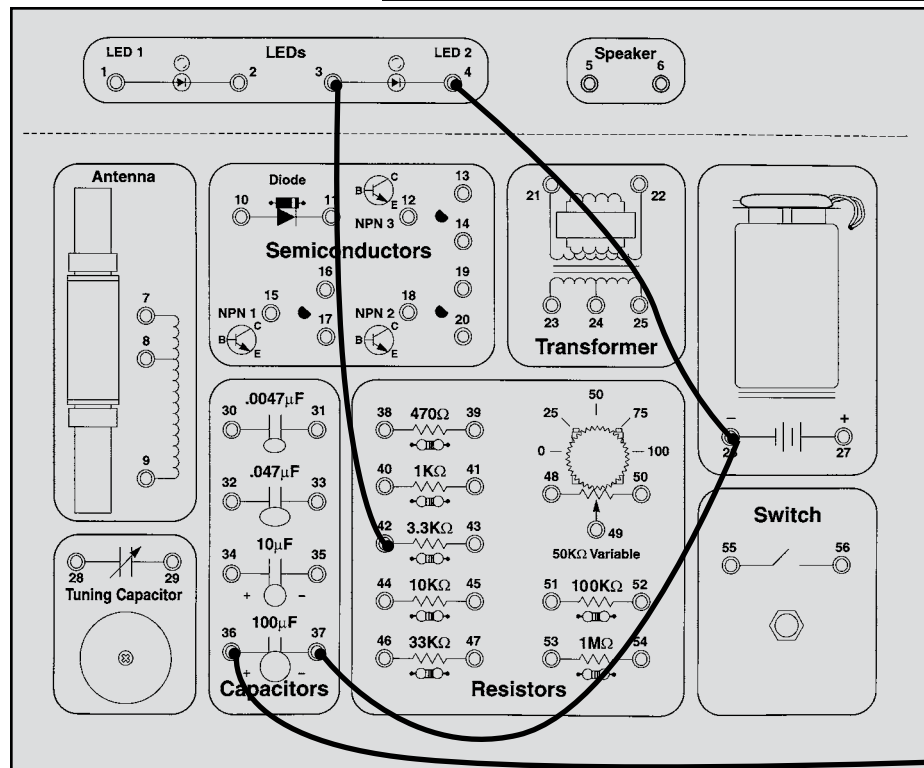

## TEST YOUR KNOWLEDGE #1

1. \_\_\_\_\_ are the particles that flow between atoms as part of an electric current.
2. A \_\_\_\_\_ circuit occurs when wires or components from different parts of the circuit accidentally connect.
3. A \_\_\_\_\_ produces electricity using a chemical reaction.
4. To decrease the current in a circuit you may decrease the voltage or \_\_\_\_\_ the resistance.
5. Materials which have very high resistance are called \_\_\_\_\_ and materials which have very low resistance are called \_\_\_\_\_.
6. Adding resistors in parallel \_\_\_\_\_ the resistance while adding resistors in series \_\_\_\_\_ the resistance.
7. The electrical resistance of water \_\_\_\_\_ when salt is dissolved in it.
8. Capacitors are components that can store \_\_\_\_\_ for periods of time.
9. Capacitors have low resistance to \_\_\_\_\_ current and high resistance to \_\_\_\_\_ current.
10. Adding capacitors in parallel \_\_\_\_\_ the capacitance while adding capacitors in series \_\_\_\_\_ the capacitance.

(Answers are on page 5).

## INTRODUCTION TO DIODES

The Diode: The **diode** is an electronic device that allows current to flow in only one direction. In our water pipe analogy it may be thought of as the check valve shown here:

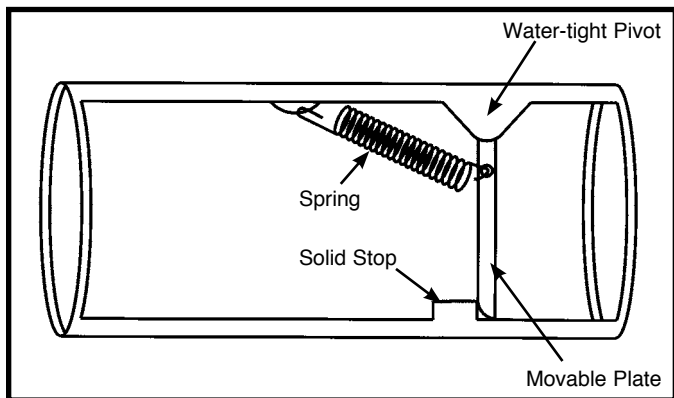

The check valve only allows water to flow in one direction, to the right in this drawing. There is a small spring and if the water pressure exceeds a certain level then the spring will be stretched and the valve opened. If the pressure is to flow to the left then the plate will be pressed against the solid stop and no water will flow.

Electronic diodes are made from materials called **semiconductors**, so-called because they have more resistance than metal conductors but less than insulators. Most semiconductors are made of Silicon but Gallium Arsenide and Germanium are also used. Their key advantage is that by using special manufacturing processes their resistance is decreased under certain operating conditions. The manufacturing processes create two regions of permanent electrical charge, quite different from charging a capacitor. While the physics of how this works is quite complicated, the effect is that once the voltage across the diode exceeds a small turn-on level (0.7V for Silicon) the resistance of the diode becomes very low in one direction (so low in fact that the current flow must be limited by other resistances in the circuit to prevent damage to the diode). When the diode is turned on like this we refer to it as being **forward-biased**. In the other direction the diode is always a very high resistance, we call this **reverse-biased**. The schematic symbol, shown below, indicates that the diode will allow current to flow from left to right but block current flow from right to left.

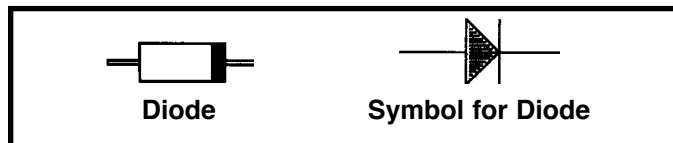

## EXPERIMENT #11: One-way Current

Connect the wires according to the Wiring Checklist and press the switch, the LED lights up. The diode's turn-on voltage of 0.7V is easily exceeded and the diode has little effect on the circuit. Now reverse the wires to the diode and try again, nothing happens. The diode is now reverse-biased and blocks current flow through the circuit, just like the plate and solid stop block the water flow in the drawing shown above.

You've probably noticed a similarity between the schematic symbols for the diode and the LED. Re-wire the diode back to forward-biased or remove it from the circuit and then reverse the wires to the LED. Press the switch and LED doesn't light, do you know why?

Starting now, the equivalent water diagrams will no longer be presented.

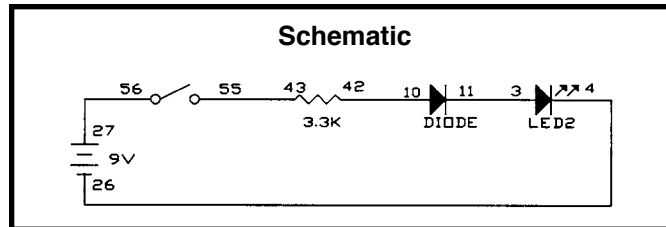

### Wiring Checklist:

- 27-to-56
- 55-to-43
- 42-to-10
- 11-to-3
- 4-to-26

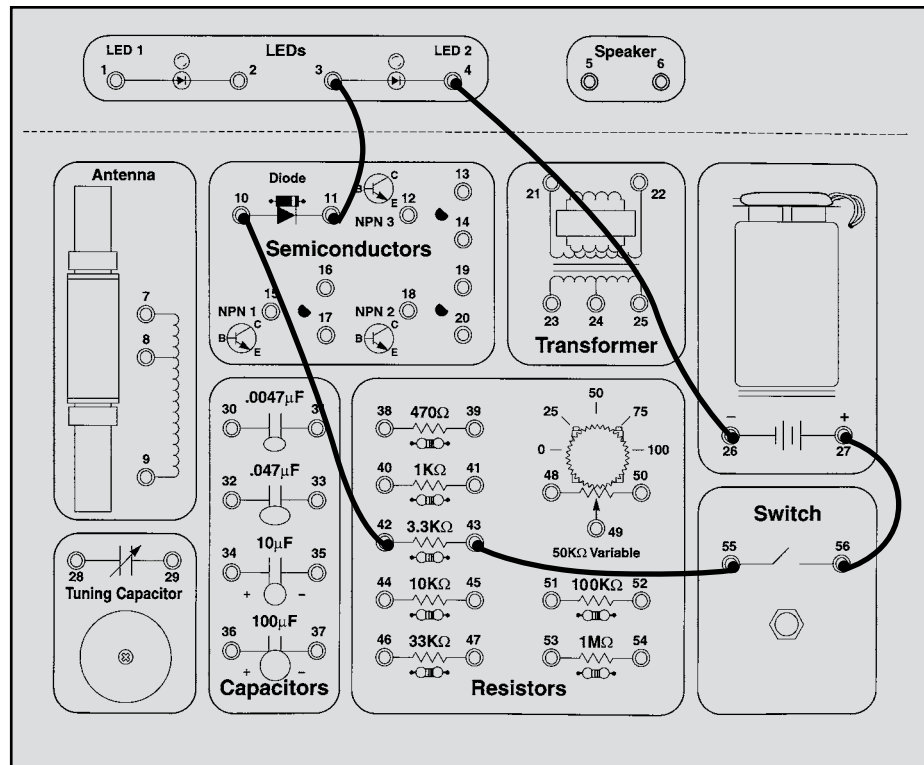



# EXPERIMENT #12: One-way Lightbulbs

Diodes made of Gallium Arsenide need a higher voltage across them to turn on, usually about 1.5V This turn-on energy is so high that light is generated when current flows through the diode. These diodes are the light emitting diodes that you have been using.

To demonstrate this, connect the wires according to the Wiring Checklist. Touch the loose wire to the battery and watch LED1. It will be bright initially as a current flows to charge up the 100µF capacitor and then will dim as the

capacitor voltage reaches the battery voltage. LED2 will not light since it is reverse-biased. Then touch the loose wire to the negative side of the battery (“ground”) and watch LED2. It will be bright initially as a current flows to discharge the 100µF capacitor and then will dim as the capacitor voltage drops to zero. LED1 will not light since now it is reverse-biased.

As in Experiment #10, you may try different resistor values in this circuit if you like.

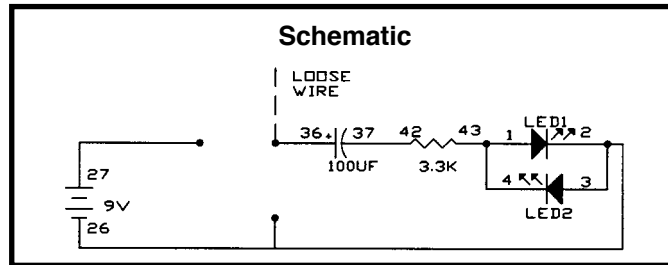

### Wiring Checklist:

- 37-to-42
- 43-to-1-to-4
- 2-to-3-to-26
- 36-to-unconnected (use a long wire)

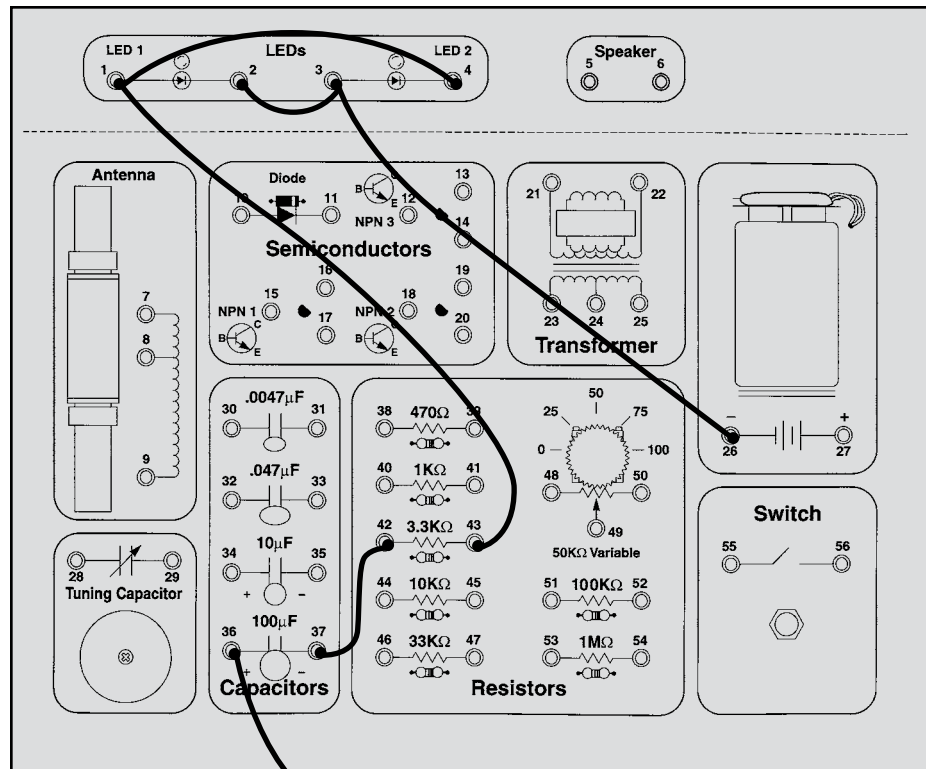

Loose Wire

## INTRODUCTION TO TRANSISTORS

The Transistor: The **transistor** was first developed in 1949 at Bell Telephone Laboratories, the name being derived from “transfer resistor”. It has since transformed the world. Did you ever hear of something called a vacuum tube? They are large and can be found in old electronic equipment and in museums. They are seldom used today and few engineers even study them now. They were replaced by transistors, which are much smaller and more reliable.

The transistor is best described as a current amplifier - it uses a small amount of current to control a large amount of current. There are many different families of transistors but we will only discuss the type included in your Electronic Playground, called the NPN Bipolar Junction Transistor or BJT and made of the semiconductor silicon. It has three connection points, called the emitter, base, and collector.

In our water pipe analogy the BJT may be thought of as the lever pivot shown here:

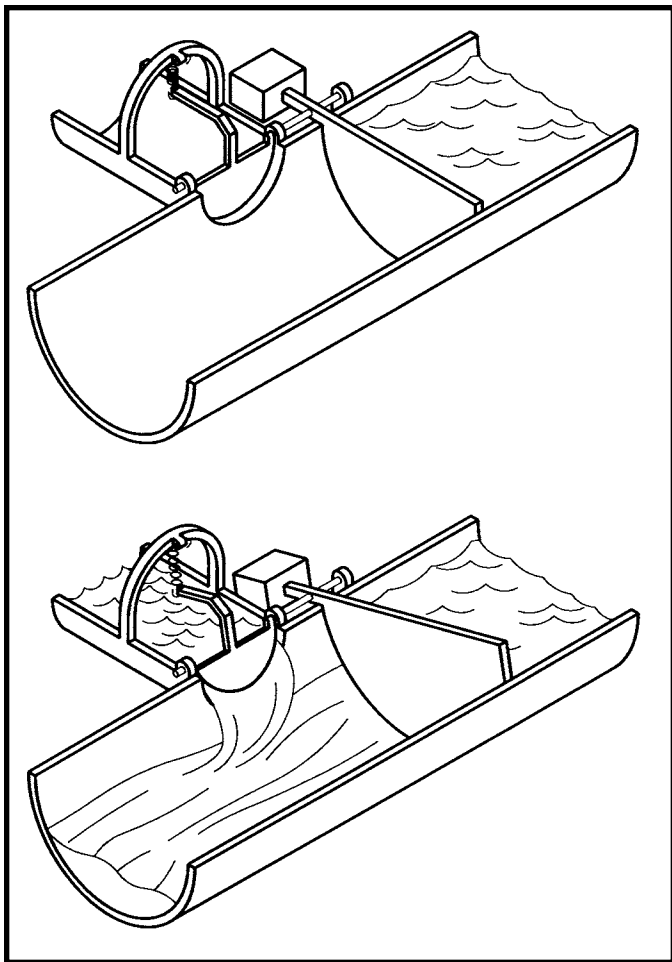

Notice that it includes a check valve that is connected to a lever arm. A small amount of “base current” pushes on the check valve which turns and opens the lever arm. But before this base current can start to flow though it must have enough water pressure to overcome the spring in the check valve (usually 0.7V). If the base pipe is much smaller than the collector and emitter pipes, then a small base current  $I_B$  flowing in will cause a large collector current  $I_C$  to flow in, these will combine and exit the device as emitter current  $I_E$ .

In transistors the emitter, base, and collector are different regions of permanent electrical charge, producing the effects described above for the lever pivot. The properties and uses of transistors may seem confusing at first but will become clear as you proceed through the experiments. All but one of the remaining experiments will use the transistor, so its importance to electronics should be apparent.

A key advantage of semiconductors is that several transistors can be manufactured on a single piece of silicon. This led to the development of **Integrated Circuit** (IC) technology, in which careful control of complex manufacturing processes has enabled entire circuits consisting of transistors, diodes, resistors, and capacitors to be constructed on a silicon base. Some ICs used in computers now have more than a million transistors on them. Spectacular improvements in cost, size, and reliability have been achieved as a result.

The schematic symbol for a transistor is shown below:

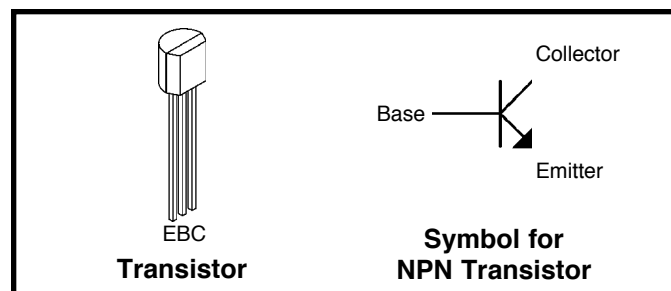

Note the small arrow in the emitter, this indicates which direction the current will flow through the device.

## EXPERIMENT #13: The Electronic Switch

Connect the wires according to the Wiring Checklist. Although there is a closed circuit with the battery,  $1K\Omega$ , LED, and transistor, no current will flow since the transistor is acting like an open circuit (with no base current the lever arm remains shut). Press the switch; a base current now flows and opens the lever arm,

resulting in a large collector current which lights the LED. The transistor is being used as an electronic switch. Although there is still a normal switch in this circuit, there could be many electronic switches controlled by one normal switch.

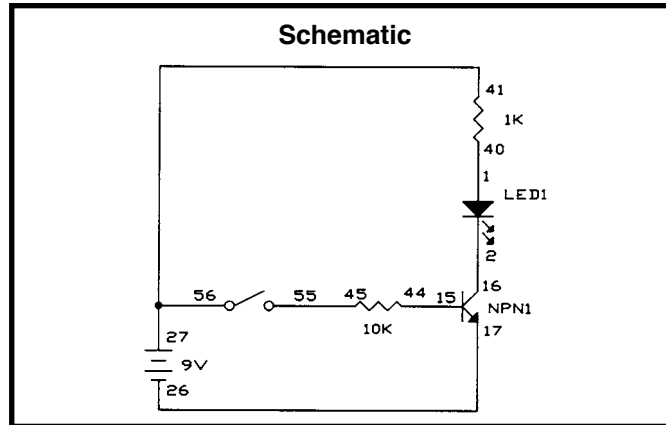

### Wiring Checklist:

- 41-to-27-to-56
- 55-to-45
- 44-to-15
- 17-to-26
- 40-to-1
- 2-to-16

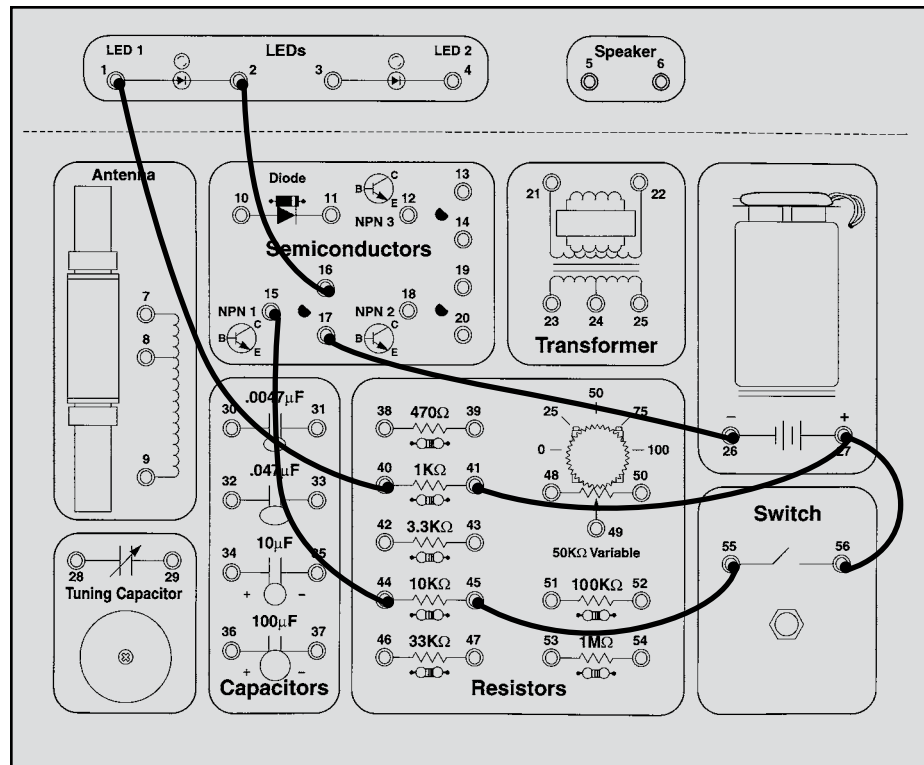

## EXPERIMENT #14: The Current Amplifier

Connect the wires according to the Wiring Checklist and press the switch. LED 1 in the collector path is brighter than LED 2 in the base path because the base current is amplified by the transistor. The current gain of a transistor varies anywhere from 10 to 1000 depending on the type of transistor, the ones in your Electronic Playground have a gain of about 200.

Note that the battery voltage and circuit resistance will limit the current gain. For example, if you replace the 1K $\Omega$  in this circuit with a 33K $\Omega$  then the current gain will only be about 3. The circuit resistances, not transistor itself, are limiting the current and the transistor is said to be **saturated**.

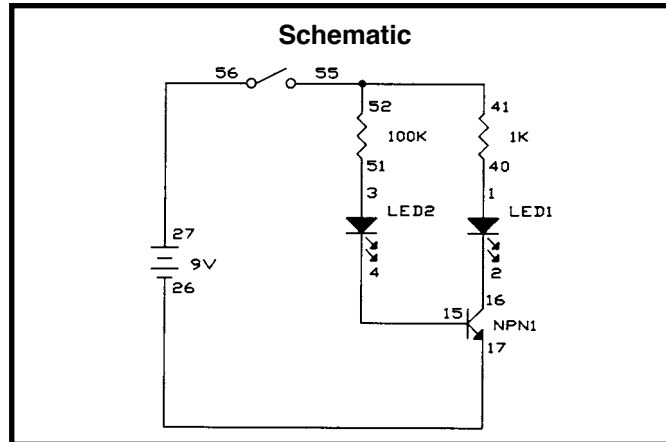

### Wiring Checklist:

- 27-to-56
- 52-to-55-to-41
- 40-to-1
- 2-to-16
- 17-to-26
- 15-to-4
- 3-to-51

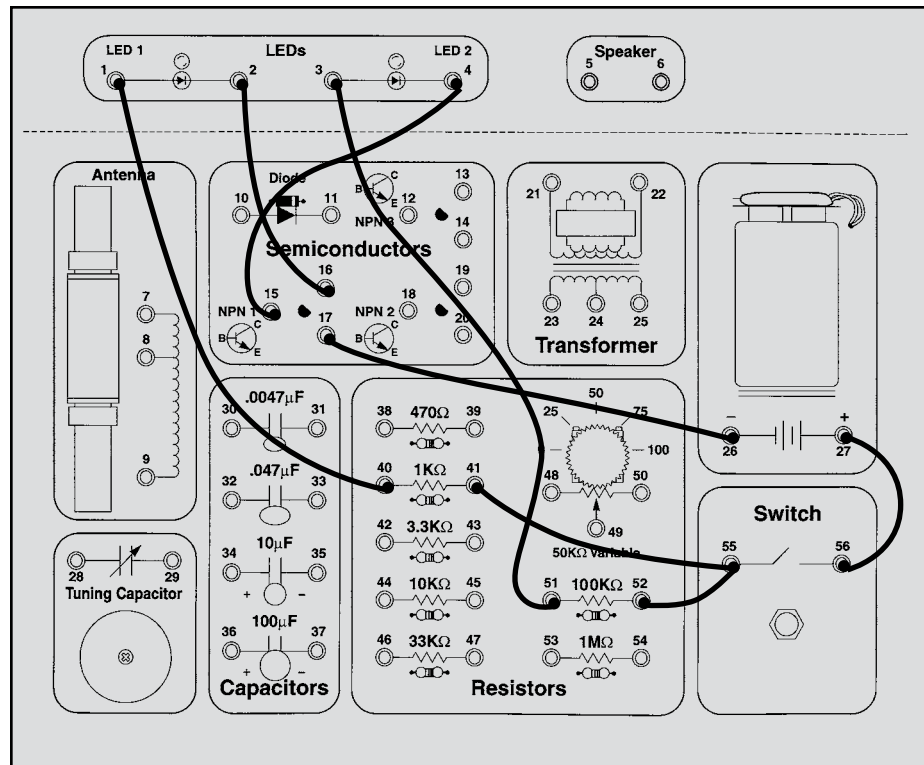

# EXPERIMENT #15: The Substitute

Look again at the water pipe analogy for the transistor, the lever pivot:

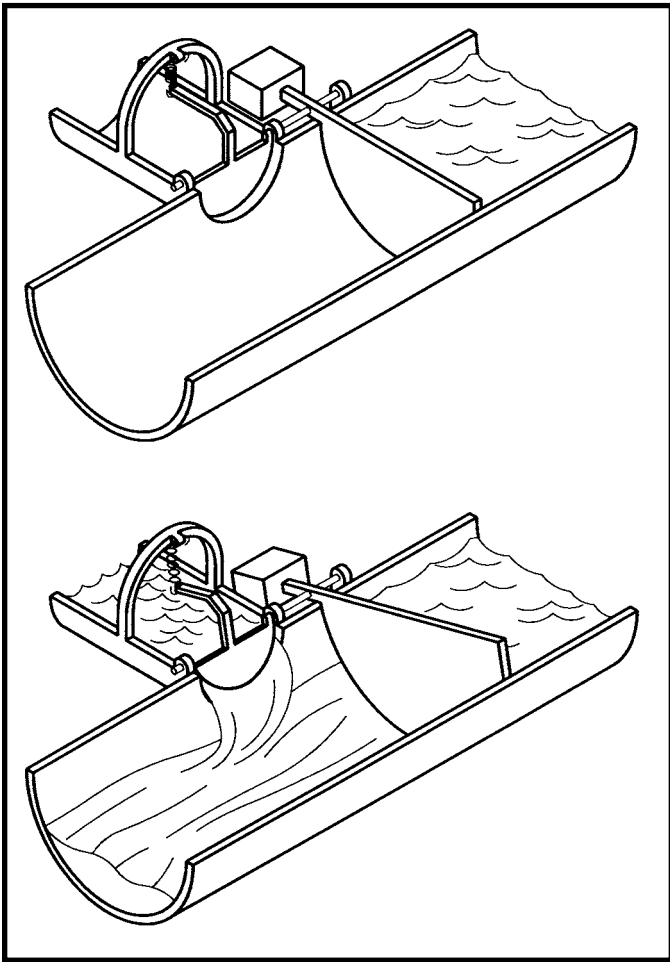

What would happen if the base and collector were connected together? Once there is enough pressure to overcome the spring in check valve DE (0.7V) there would be only slight resistance and no current gain. This situation should sound familiar since this is exactly how a diode operates. When the base and collector of a transistor are connected together the transistor becomes a diode.

Connect the wires according to the Wiring Checklist and press the switch, the LED lights. This is the same circuit as Experiment 11, One-Way Current. This demonstrates how transistors can be substituted for diodes, and this will occur in practice sometimes for manufacturing reasons.

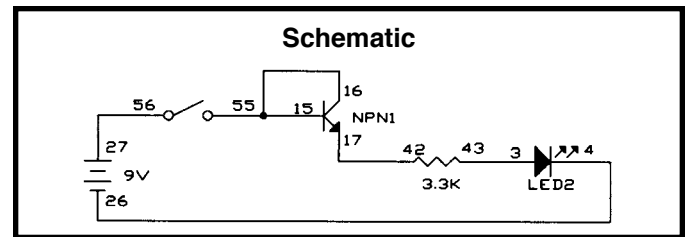

### Wiring Checklist:

- 27-to-56
- 55-to-16-to-15
- 17-to-42
- 43-to-3
- 4-to-26

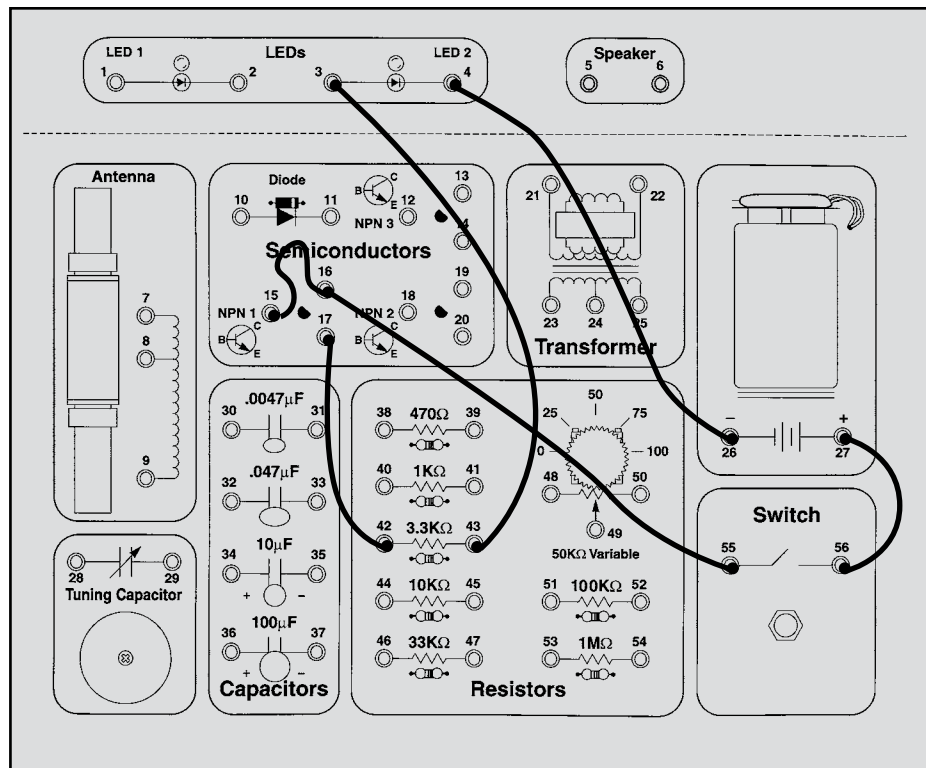

## EXPERIMENT #16: Standard Transistor Biasing Circuit

Connect the wires according to the Wiring Checklist and press the switch while turning the variable resistor from right to left (from  $0\Omega$  to  $50K\Omega$ ). The  $100K\Omega$  and variable  $50K\Omega$  are a voltage divider that sets the voltage at the transistor base. If this voltage is less than  $0.7V$  then the transistor will be off and no current will flow through the LED. As the base voltage increases above  $0.7V$  a small base current starts to flow, which is amplified to produce a larger collector current that lights the LED. As the base voltage continues to increase the transistor becomes saturated and the LED brightness will not increase further.

This circuit will normally be used with the voltage divider set so that the transistor is turned on but is not saturated. Although this circuit does not have many applications by itself, when a small alternating current (AC) signal is applied to the base then a larger copy of the signal will appear at the collector - a small-signal amplifier!

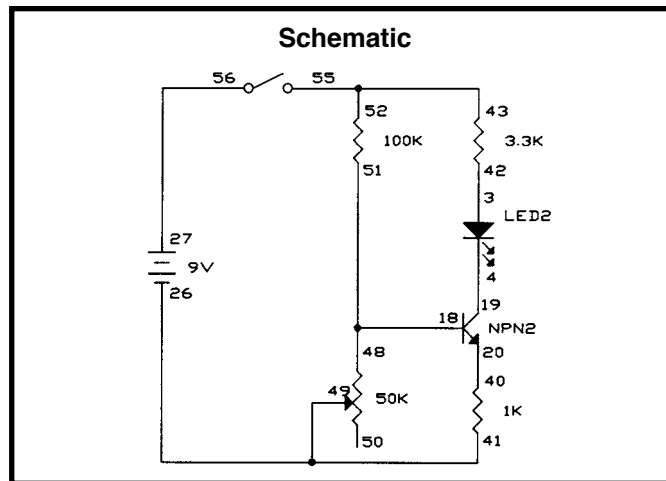

### Wiring Checklist:

- 27-to-56
- 55-to-52-to-43
- 42-to-3
- 4-to-19
- 18-to-48-to-51
- 20-to-40
- 41-to-49-to-26

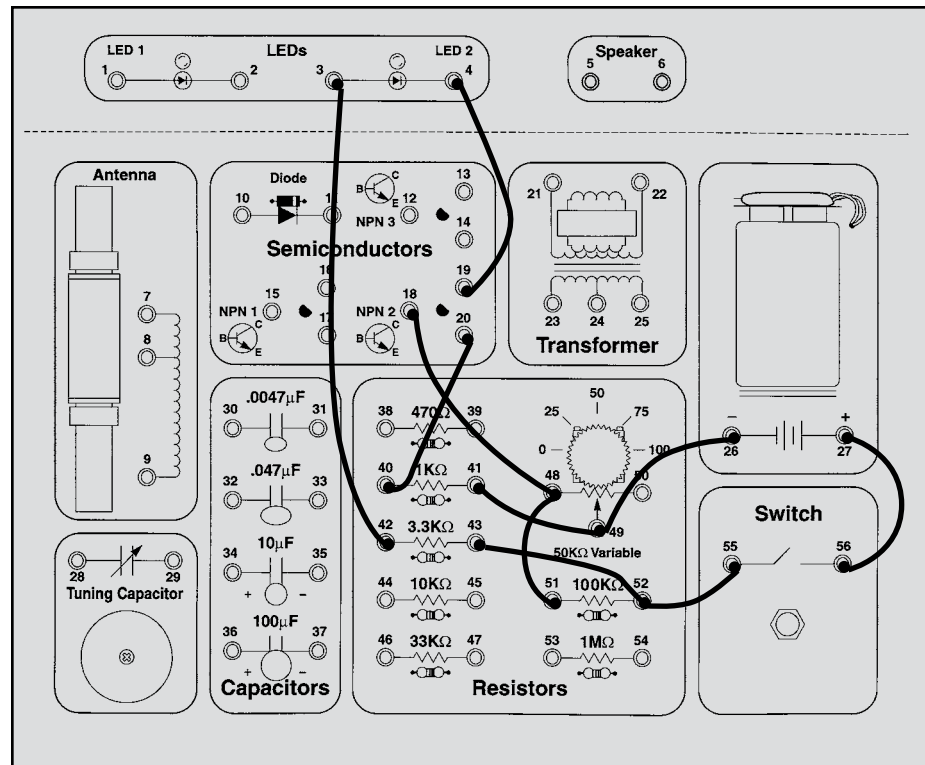

## EXPERIMENT #17: Very Slow Light Bulb

Connect the wires according to the Wiring Checklist and press the switch, hold it down for several seconds. The LED will slowly light up. Release the switch and the LED will slowly go dark.

When you first press the switch all of the current flowing through the 100K $\Omega$  resistor goes to charge up the capacitor, the transistor and LED will be off. When the capacitor voltage rises to 0.7V the transistor will first turn on and the LED will turn on. As the capacitor voltage continues to rise the current flow through the 470 $\Omega$  resistor and into the transistor base will increase. The current through the LED will then rise rapidly due to the transistor's current gain.

When the switch is released the capacitor will discharge through the 470 $\Omega$  resistor and the transistor base, the

LED will dim as this discharge current decreases. When the capacitor voltage drops below 0.7V the transistor will turn off. If you get impatient you may touch a wire between the two capacitor springs to discharge it instantly.

Do you know how to change the capacitor charge and discharge times? The 100K $\Omega$  resistor controls the charge time, the 470 $\Omega$  controls the discharge, and the capacitor controls both the charge and discharge. Replace these parts with some different values and observe the effects.

Compare this circuit to the one you used in Experiment 7 when we first introduced the capacitor. By adding a transistor you can use a large resistor for a slow charge time and still have a bright LED!

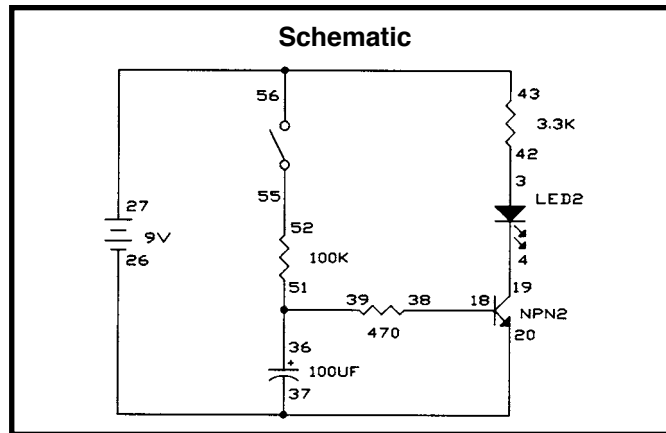

### Wiring Checklist:

- 43-to-27-to-56
- 55-to-52
- 36-to-51-to-39
- 38-to-18
- 42-to-3
- 4-to-19
- 20-to-26-to-37

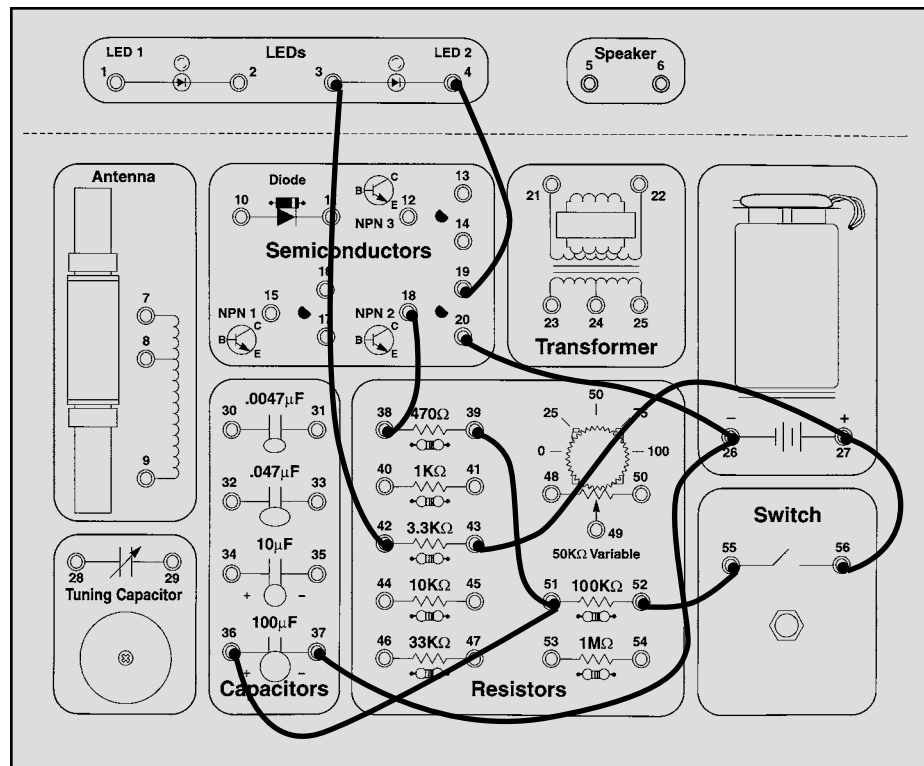

## EXPERIMENT #18: The Darlington

This circuit is very similar to the last one. Connect the wires according to the Wiring Checklist and press the switch, hold it down for several seconds. The LED will slowly light up. Release the switch and the LED stays lit.

Take a look at the schematic. All the current flowing through the emitter of NPN1 will flow to the base of NPN2. So the current flowing into the base of NPN1 will be amplified twice, once by each transistor. This configuration is called the **Darlington configuration**. It has very high current gain and very high input resistance

at the base. Since there are now two transistors to turn on, the capacitor voltage must exceed 1.4V before the LED will start to light. And since the input current to the base is so small it will take much longer to discharge the capacitor.

But the circuit is functionally the same as Experiment 17 and the LED will eventually go dark, though it may take a few minutes. You can experiment with changing some of the component values if you like.

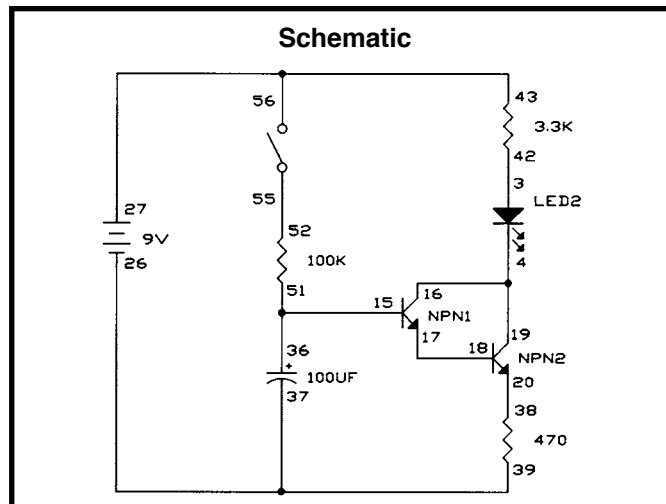

### Wiring Checklist:

- 43-to-27-to-56
- 55-to-52
- 36-to-51-to-15
- 42-to-3
- 4-to-19-to-16
- 17-to-18
- 20-to-38
- 39-to-26-to-37

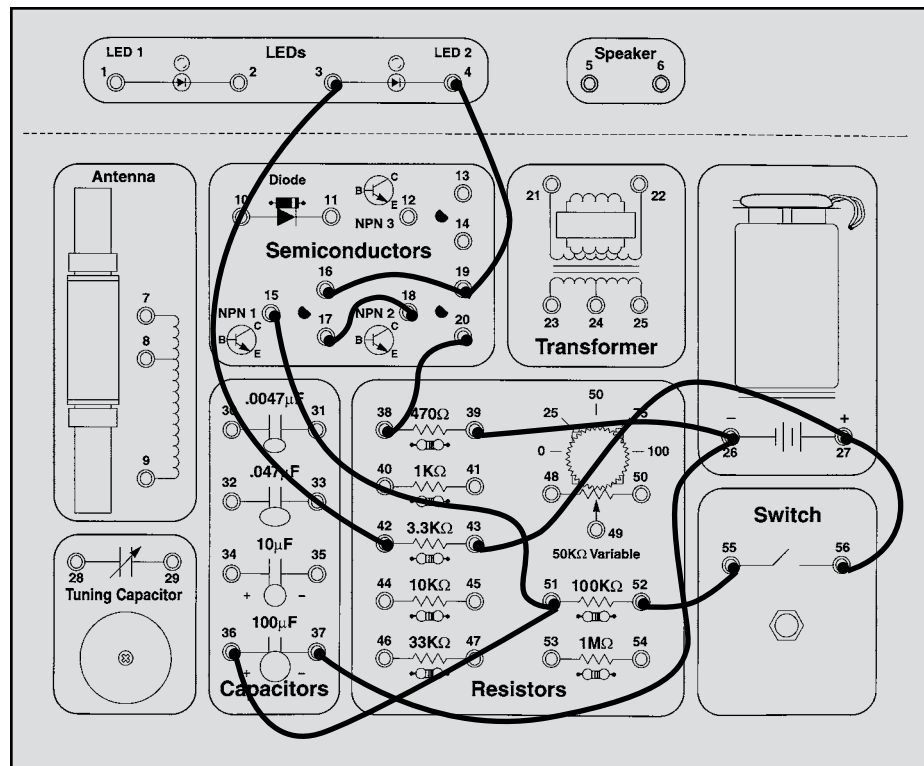



## EXPERIMENT #19: The Finger Touch Lamp

Take a look at the schematic. You're probably wondering how it can work, since nothing is connected to the transistor base. It can't, but there is another component that isn't shown in the schematic. That component is you.

Connect the wires according to the Wiring Checklist. Now touch spring 27 (the battery) with one finger and spring 18 (transistor base) with another. The LED may be dimly lit. The problem is your fingers aren't making good enough electrical contact with the springs. Wet your fingers with water or saliva and touch the springs again. The LED should be very bright now. You saw in Experiment 6 how water can conduct electricity and since your body is mostly water it shouldn't surprise you that your body can also conduct. Your body's resistance varies a lot, but is typically a few hundred kilohms. Think of this circuit as a touch lamp since when you touch it the LED lights. You may have seen such a lamp in the store or already have one in your home.

Actually, the touch lamps you see in stores only need to be touched by one finger to light, not two. So let's see if we can improve our circuit to only need one finger. Connect a wire from spring 27 to spring 54, and another from spring 18 to spring 52. Wet a large area of one of your fingers and touch it to springs 52 and 54 at the same time; the LED lights. To make it easier for one finger to touch the two contacts, touch lamps or other touch devices will have the metal contacts interweaved

as shown below and will also be more sensitive so that you don't have to wet your finger to make good contact. This circuit is still different from the touch lamps sold in

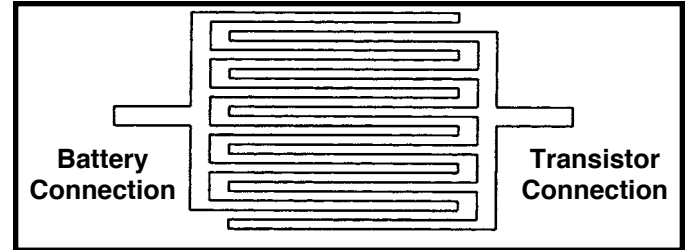

stores because the LED goes dark if you remove your finger from it. We need a way of remembering when you've touched the lamp to turn it on or off - we need a memory, and we'll show you one in Experiment 46.

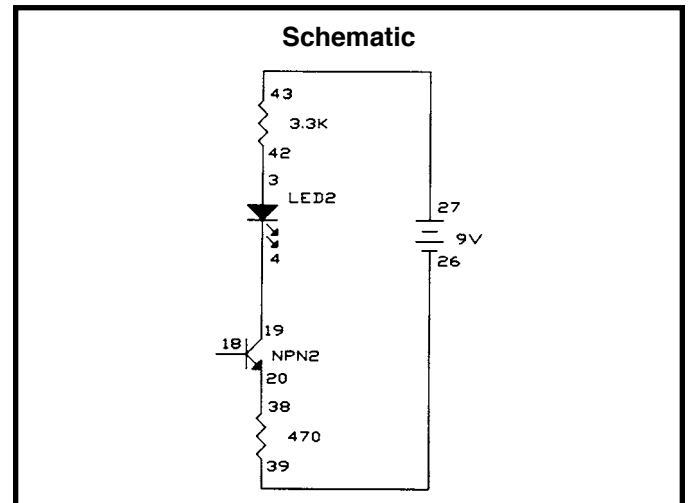

### Wiring Checklist:

- 27-to-43
- 42-to-3
- 4-to-19
- 20-to-38
- 39-to-26

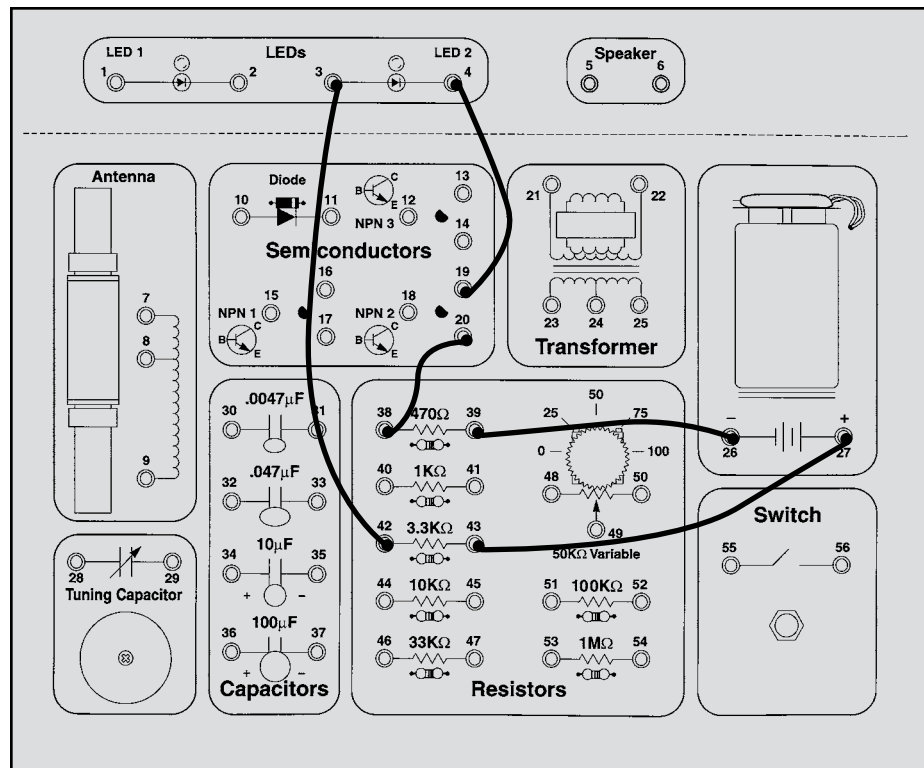

## EXPERIMENT #20: Battery Immunizer

Connect the wires according to the Wiring Checklist and schematic. Note that the collectors of NPN2 and NPN3 are not connected although their wires cross over each other in the schematic. Connect the loose wire from spring 43 (3.3KΩ) to spring 16 (NPN1 collector, or 9V); the LED is bright. Now connect the wire to spring 17 (NPN1 emitter) instead of spring 16; the LED is just as bright. So we made a change and nothing happened, does this seem like a dull experiment? It may seem dull but the important idea here is that we made a big change to the circuit but nothing happened to the LED.

Take a look at the schematic. The circuit to the left of the loose wire reduces the voltage to 4.7V. You connect the loose wire to either the 9V battery voltage or the modified 4.7V. The circuit to the right of the loose wire creates a fixed current to the LED, which will not change even if the voltage (9V or 4.7V) to the circuit changes. So when you changed which voltage the loose wire was connected to you didn't see any change in LED brightness.

In case you're not convinced by this, let's change the circuit to prove it. Place LED2 in series with the 3.3KΩ resistor (remove the wire from spring 42 and connect it to spring 2, and add a wire from spring 1 to spring 42). Now connect the loose wire to the two voltages as before and

you should see LED2 change between bright and dark while LED1 remains bright as before.

You could use a circuit like this when you don't want your performance to be affected as your voltage drops, perhaps due to a battery weakening over a long period of use. So you could say your circuit is immune to (protected against) a weak battery.

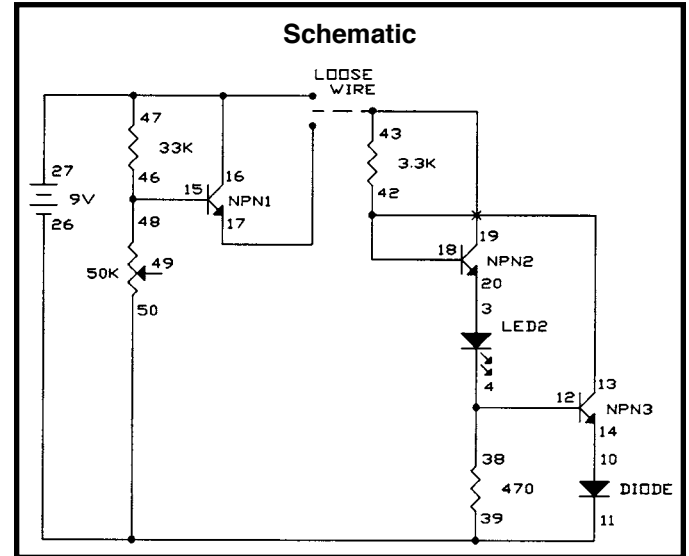

### Wiring Checklist:

- 16-to-27-to-47
- 15-to-46-to-48
- 26-to-50-to-39-to-11
- 10-to-14
- 4-to-12-to-38
- 3-to-20
- 13-to-18-to-42
- 19-to-43-to-unconnected

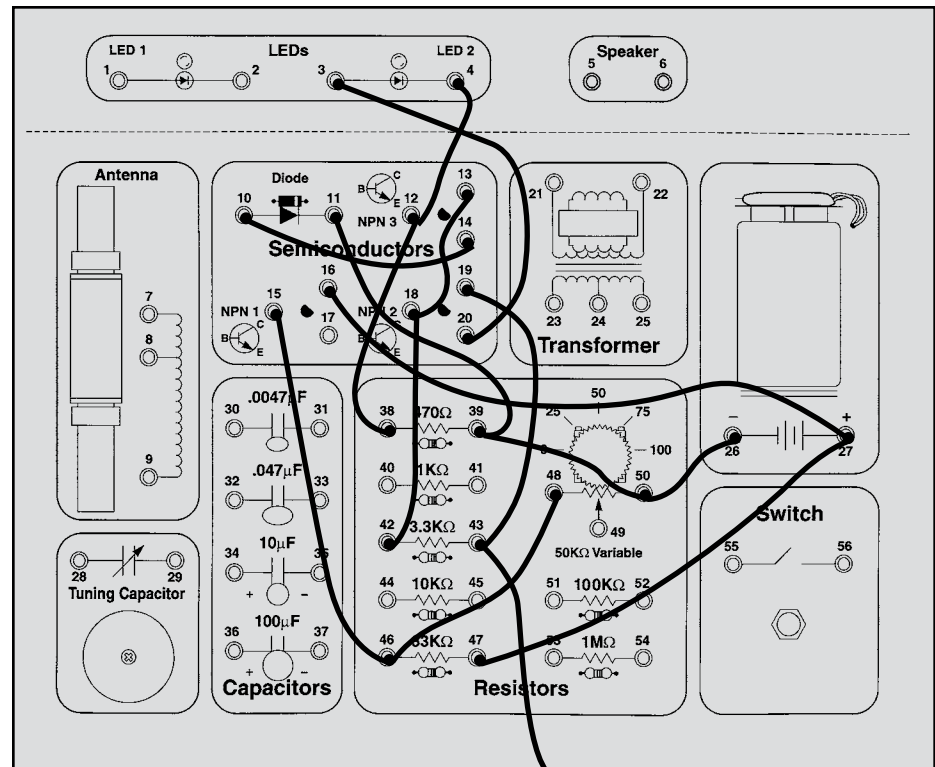

Loose Wire

# EXPERIMENT #21: The Voltmeter

Make sure you have a strong 9V battery for this experiment. Connect the wires according to the Wiring Checklist, connecting the wire to the battery last since this will turn on the circuit. And be sure to disconnect this battery wire when you're not using the circuit to avoid draining the battery. The part of the circuit to the left of the dashed line in the schematic is the voltmeter, the two resistors on the right produce a voltage that you will measure. Notice that the variable resistor (VR) will always act as a 50KΩ across the battery but by turning its knob you adjust the voltage at the base of NPN1. By turning this knob you can make one LED brighter than the other, indicating that the voltages at the bases of NPN1 and NPN2 are not equal. Adjust the VR so that the two LEDs are equally bright. The transistor base voltages are now equal. To determine what voltage you have measured, simply subtract the percentage shown on your VR dial from 100 and multiply by 0.09.

If you like you can calculate what voltage you should have measured. Your measurement may differ from this due to the tolerances in the resistors and the VR dial, but you should be close. The resistors on the right are a voltage adjuster, just like the VR is, and the voltage you measured (at the base of NPN2) is:

$$V_{\text{Calculated}} = \frac{R_{\text{Lower}}}{R_{\text{Upper}} + R_{\text{Lower}}} \times V_{\text{Battery}} = \frac{33\text{K}\Omega}{10\text{K}\Omega + 33\text{K}\Omega} \times 9\text{V} = 6.9\text{V}$$

Upper Resistor	Lower Resistor	Measured Voltage	Calculated Voltage
10KΩ	33KΩ		6.9V
33KΩ	10KΩ		2.1V
33KΩ	100KΩ		6.8V
100KΩ	33KΩ		2.2V
3.3KΩ	10KΩ		6.8V
10KΩ	3.3KΩ		2.2V
1KΩ	3.3KΩ		6.9V
3.3KΩ	1KΩ		2.1V
10KΩ	parallel 33KΩ, 100KΩ		6.4V
parallel 33KΩ, 100KΩ	10KΩ		2.6V
series 10KΩ, 33KΩ	100KΩ		6.3V
100KΩ	series 10KΩ, 33KΩ		2.7V
1KΩ	parallel 3.3KΩ, 10KΩ		6.4V
parallel 3.3KΩ, 10KΩ	1KΩ		2.6V
series 1KΩ, 3.3KΩ	10KΩ		6.3V
10KΩ	series 1KΩ, 3.3KΩ		2.7V

This circuit is a form of the **Differential Pair** transistor configuration, which is widely used in integrated circuits. If the transistor base voltages are equal then the currents through the LEDs and collectors will also be equal. If one base voltage is higher than the other then that transistor will have more current flowing through it's collector and associated LED.

You can now replace the two resistors on the right with a different combination and make a new voltage measurement. The table below lists different combinations of your Electronic Playground resistors that you can measure, but you don't have to measure them all. In some combinations resistors are placed in series or parallel to create new values.

Remember to disconnect the battery wire when you're not using the circuit to avoid draining the battery.

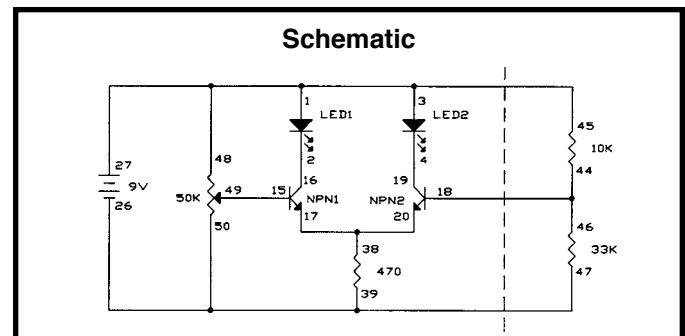

### Wiring Checklist:

- 1-to-3-to-27-to-48-to-45
- 26-to-50-to-39-to-47
- 15-to-49
- 2-to-16
- 4-to-19
- 38-to-17-to-20
- 18-to-44-to-46

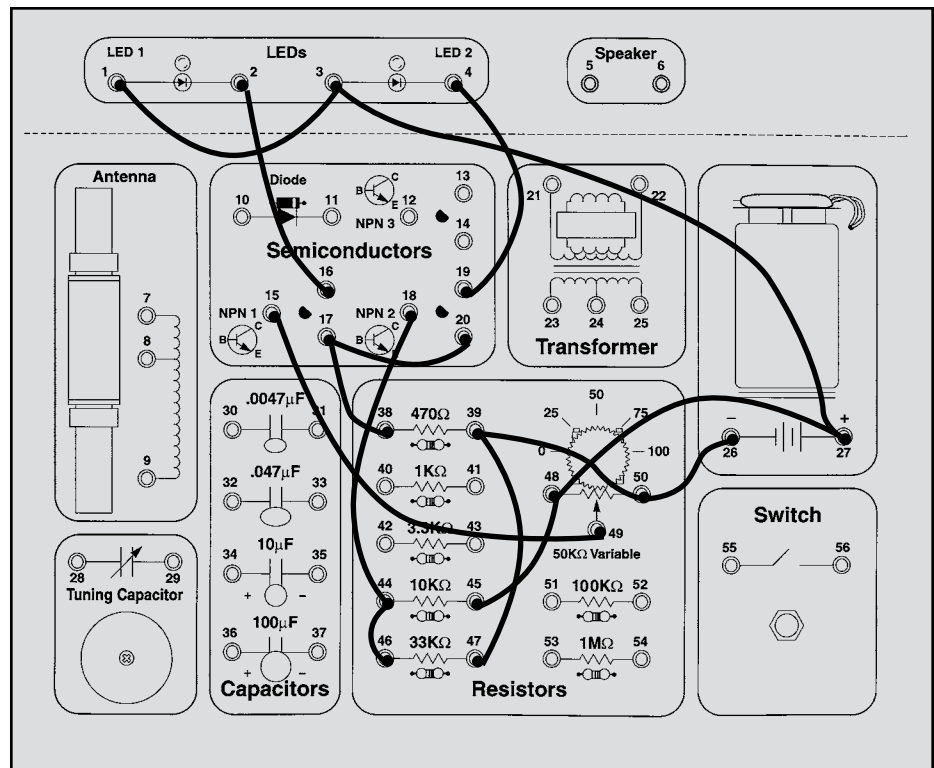

## EXPERIMENT #22: 1.5 Volt Battery Tester

Make sure you have a strong 9V battery for this experiment. Connect the wires according to the Wiring Checklist, connecting the wire to the battery last since this will turn on the circuit. And be sure to disconnect this battery wire when you're not using the circuit to avoid draining the battery. This circuit is a variation of the differential pair configuration used in Experiment 21, you will use it to test your 1.5V batteries. Take any 1.5V battery you have (AAA, AA, A, B, C, or D cells) and connect it between the base of NPN2 and ground. The easiest way to do this is to stand your battery (negative side down) on battery spring 26, connect a wire to spring 18 (the base of NPN2), and hold the wire to the positive side of your battery.

If LED2 is bright and LED1 is off then your 1.5V battery is good, otherwise your 1.5V battery is weak and should be replaced soon. Don't throw any weak batteries away without making sure some measure good with this test because all batteries could fail if your circuit is wired incorrectly, or if your 9V battery is weak.

This circuit uses two diodes (NPN3 is being used as a diode) to create a voltage reference. The turn-on voltage drops for the diodes are combined to produce a constant voltage of about 1.1V at the base of transistor NPN1. (We said earlier that a diode turn-on voltage is 0.7V, but it varies slightly depending on the current. In this application the drops will be about 0.55V for each). This is compared to the 1.5V battery voltage at the base of NPN2, in the same manner as Experiment 21. A strong 1.5V battery will easily exceed 1.1V and only NPN2 and LED2 will be on, while NPN1 will be shut off. But if the 1.5V battery is weak then the base voltages will be nearly equal and NPN1 and LED1 will also be on. Diodes are often used to make voltage references like this in electronic circuits.

Remember to disconnect the battery wire when you're not using the circuit to avoid draining the 9V battery.

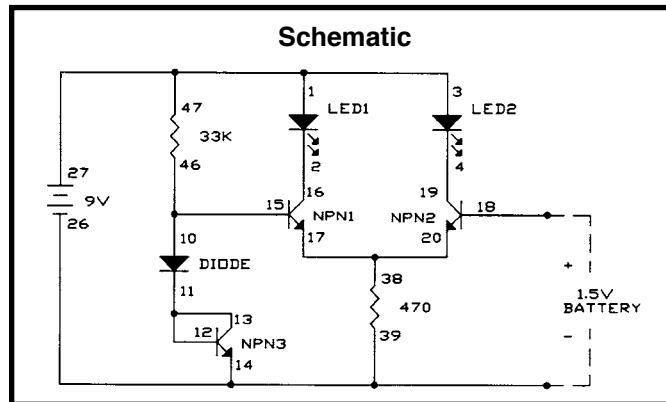

### Wiring Checklist:

- 1-to-3-to-27-to-27
- 26-to-39-to-14
- 10-to-15-to-46
- 11-to-12-to-13
- 2-to-16
- 4-to-19
- 38-to-17-to-20

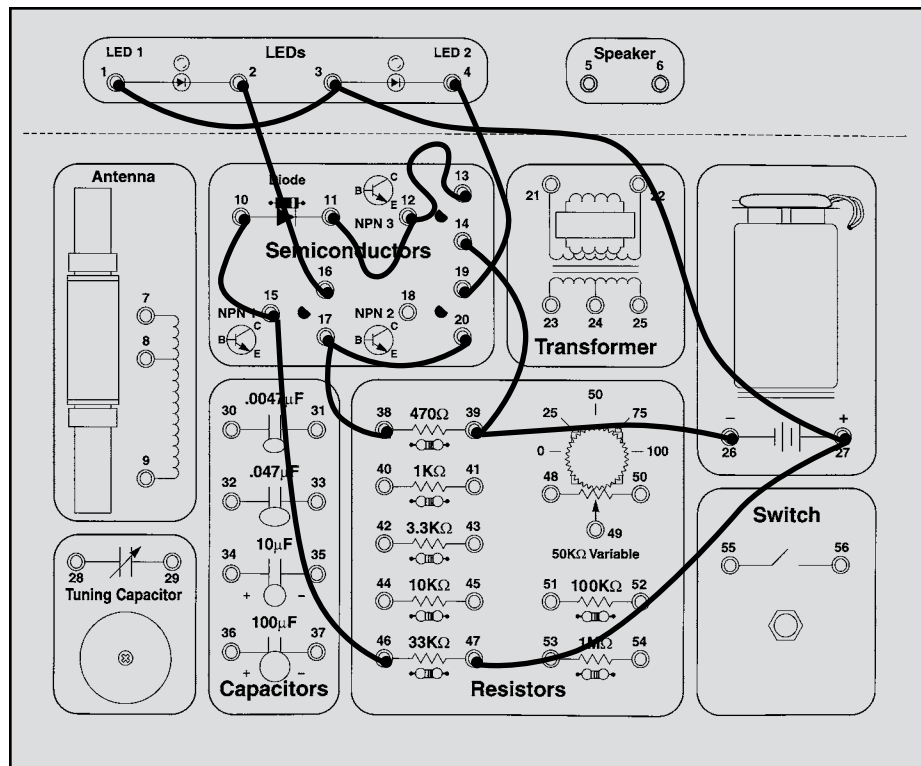

## EXPERIMENT #23: 9 Volt Battery Tester

Make sure you have a strong 9V battery for this experiment. Connect the wires according to the Wiring Checklist, connecting the wire to the battery last since this will turn on the circuit. And be sure to disconnect this battery wire when you're not using the circuit to avoid draining the battery. This time you will measure 9V batteries, just like the one you are using to power your Electronic Playground. Take two long wires and connect one to spring 26 (ground) and spring 43 (3.3K $\Omega$ ). When you are ready touch the other ends to the battery you want to test, being sure to connect them to the positive and negative battery terminals as shown in the schematic. If LED2 is bright and LED1 is off then your battery is good, otherwise your battery is weak and should be replaced soon. Don't throw any weak batteries away without making sure some measure good with this test because all batteries could fail if your circuit is wired incorrectly.

As you'd expect, this circuit is similar to Experiments 21 and 22. From the schematic you can see that we are using resistors to set the voltages at the bases of the transistors. The resistor values were selected so that if the two battery voltages are equal then NPN2's base will have a higher voltage and only LED2 will be lit (as in Experiment 22 when we had a good 1.5V battery). In fact, LED1 will only be on if your Playground's battery voltage is at least 2V higher than that of the battery you are testing. We do this because we don't want to reject a good battery that's just not as good as our reference battery. Of course, if our reference battery is weak then any battery tested will appear good.

Remember to disconnect the battery wire when you're not using the circuit to avoid draining the 9V battery.

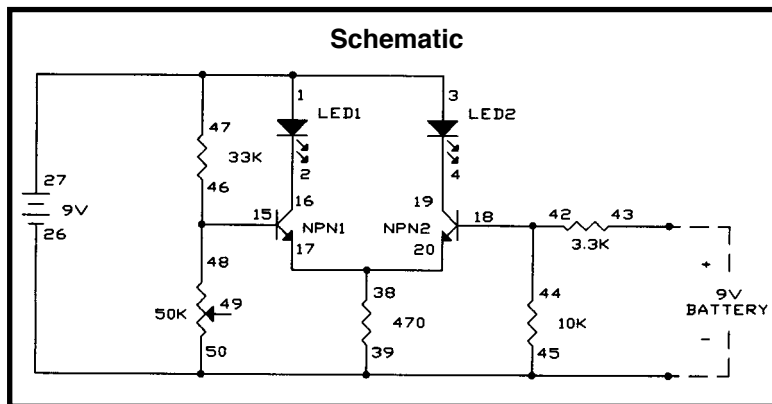

### Wiring Checklist:

- 1-to-3-to-27-to-47
- 26-to-50-to-39-to-45
- 15-to-46-to-48
- 2-to-16
- 4-to-19
- 38-to-17-to-20
- 18-to-42-to-44

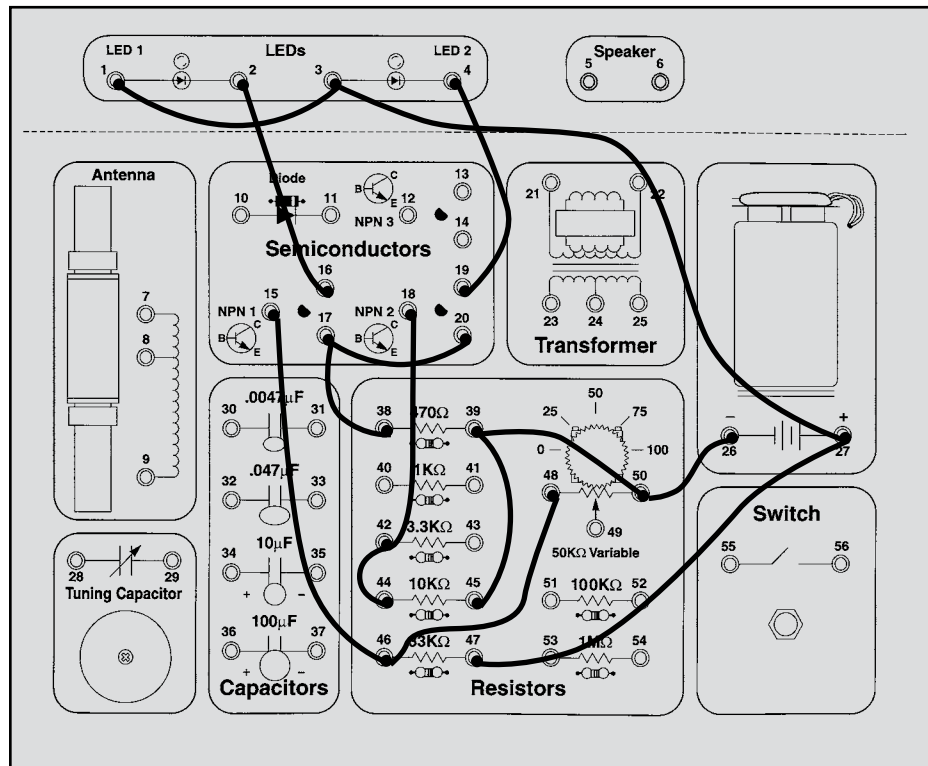

Now it's time to introduce another component . . .

## EXPERIMENT #24: The Anti-Capacitor

Recall that capacitors blocked direct current (DC) but passed alternating current (AC). Take a look at Experiment 7 again and remember that it took time to light the LED because you had to charge the capacitor first; the capacitor passed the initial current surge through to ground (the negative side of the battery) but blocked the current once it stabilized, forcing it to go through the LED. The **inductor** is the counterpart to this - it blocks current surges (AC) but passes stable currents (DC). Before explaining the inductor further, let's demonstrate it using almost the same circuit as in Experiment 7.

We will be using an inductor that is part of the transformer, we'll explain more about this later. Connect the wires according to the Wiring Checklist and press the switch several times. The LED will blink once when the switch is pressed. Note how this is different from the capacitor, when the LED became bright when the switch was pressed and stayed bright until the switch was released. The inductor effects are brief, so we are using the transistor to amplify the current to the LED and make the inductor's effects easier to see.

Now remove the wire from spring 23 (on the transformer), connect it to spring 24, and press the switch a few more times. The LED will not blink as brightly now, because we are using less inductance.

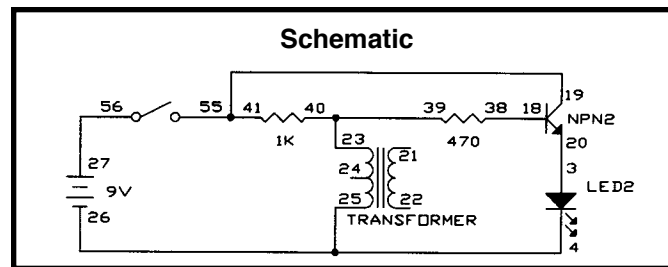

### Wiring Checklist:

- 27-to-56
- 55-to-41-to-19
- 40-to-39-to-23
- 38-to-18
- 20-to-3
- 4-to-25-to-26

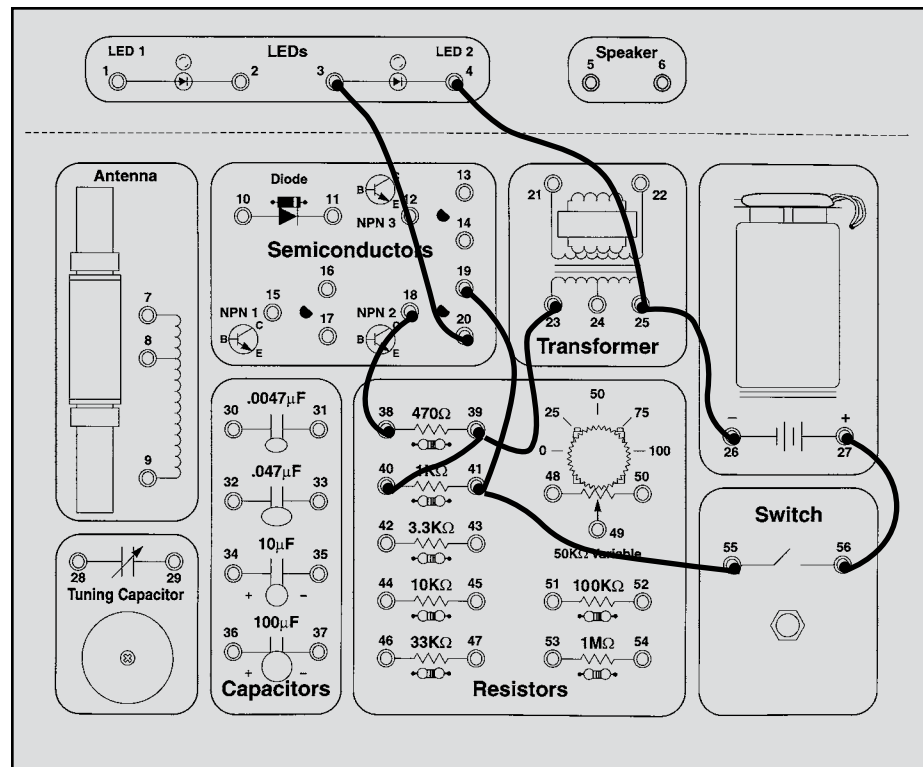

---

## NOTES

The Inductor: The inductor can best be described as electrical **momentum** (momentum is the power a moving object has). In our water pipe analogy the inductor can be thought of as a very long hose wrapped around itself many times as shown here:

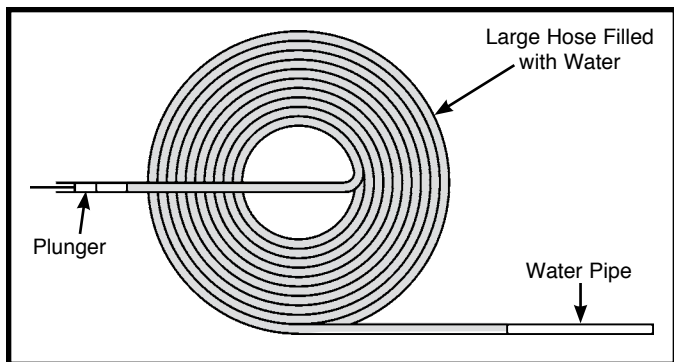

Since the hose is long it contains many gallons of water. When pressure is applied to one end of the hose with a plunger the water would not start to move instantly, it would take time to get the water moving. After a while the water would start to move and pick up speed. (This is also similar to a long freight train, which takes more than a mile to get to full speed or to stop). The speed would increase until limited by the friction (resistance) of the hose as normal. If you try to instantly stop the water from moving by holding the plunger, the momentum of the water would create a large negative pressure (suction) that would pull the plunger from your hands.

Inductors are made by coiling a wire, hence they are also called coils. From the above analogy it should be apparent that a coiled hose will pass DC (a constant or unchanging current) with only the resistance of the hose, which in electronics will be very low since the hose is a wire. If the pressure on the plunger is alternated (pushed then pulled) fast enough then the water in the coil will never start moving and the AC (constantly changing current) will be blocked. Coils in electronics follow these same principles - a coil will pass DC and block AC. Recall from above that a capacitor will block DC but pass AC. When determining the response of a circuit to DC, inductors are treated as closed switches and capacitors are treated as open switches. For the AC response, the values of the inductors and capacitors must be considered along with the rate at which the current alternates (called the **frequency**). For DC changes to the circuit (called **transients**), such as closing the switch to connect a battery to capacitor circuit, the circuit response is initially AC and then reverts to DC.

How do inductors in series and parallel add up? You saw in Experiment 24 that changing the connection point on the inductor (to reduce the length of the coiled wire) reduced LED brightness. If you think of this in terms of the coiled hose then it is easy - longer hoses will hold more water, hence more inductance. Two hoses in parallel will result in more water coming out (less inductance), since the same water pressure applies to each hose. This situation should sound familiar since inductances in series and parallel add together just like resistors do. For advanced students, the mathematical relationship is ("L" represents inductance):

$$L_{\text{Series}} = L_1 + L_2$$

$$L_{\text{Parallel}} = \frac{L_1 \times L_2}{L_1 + L_2}$$

The inductance is expressed in **henrys** (H, named after Joseph Henry who developed electromagnetic induction at the same time as Faraday), or more commonly in millihenrys (mH, thousandths of a henry) or microhenrys ( $\mu\text{H}$ , millionths of a henry). A typical inductor and its symbol are shown below:

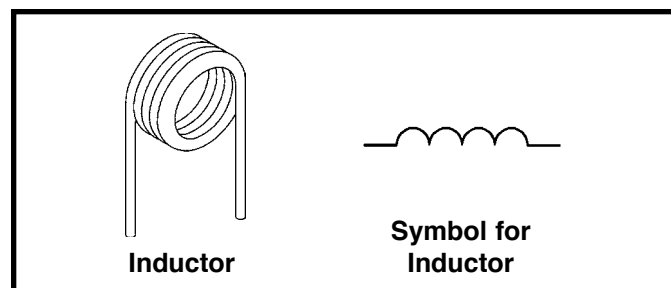

Inductors and Transformers: Our water pipe analogy we have been using all this time is not entirely accurate. Electric current is not the same as water. It is a flow of sub-atomic particles called electrons that not only have electric properties but also magnetic properties; in the water pipe analogy you would have to think of the water as containing millions of very small magnets. Inductance expresses the magnetic effects between electrons flowing in the wire of a coil. The number of turns (windings), diameter, and length of the coil affect the inductance, the thickness of the wire does not. The material inside the coil also affects the inductance; if you wrap the coil wire around an iron bar (which has strong magnetic properties) then the magnetic effects are increased and the inductance is increased. This does not apply to capacitors, which store electric charge in an electric field, not a magnetic field.



If you wrap two wires from different circuits around different ends of an iron bar then a current flowing through the wire from the first circuit will magnetically create a current in the wire from the second circuit! If the second coil has twice as many turns (more magnetic linkage) as the first coil then the second coil will have twice the voltage but half the current as the first coil. A device like this is called a **transformer**. Your Electronic Playground includes one. It consists of a 300mH coil, with a middle tap point allowing use as two connected 150mH coils, and a 3mH coil wrapped around an iron bar. In Experiment 17 we used the 300mH coil by itself but usually it will be used to drive a speaker, which needs a high current with low voltage. The symbol for a transformer is shown on the right:

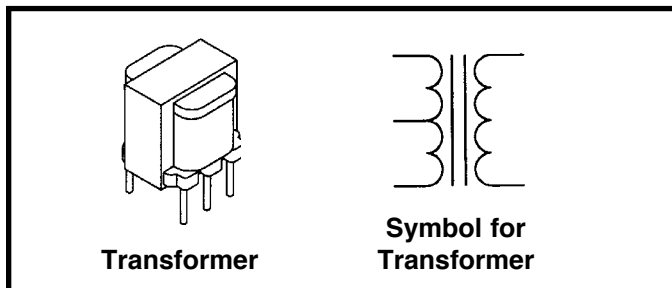

The magnetic field created in an iron bar by an electric current in the coil around it can be harnessed if the bar is allowed to rotate - it is a motor. It could be used to drive the wheels of a car, for example. The reverse is also true, if a magnet within a coil is rotating then an electric current is created in the coil - a generator. These two statements may not seem important to you at first but they are actually the foundation of our present society. Nearly all of the electricity used in our world is produced at enormous generators driven by steam or water pressure. Wires are used to efficiently transport this energy to homes and businesses where it is used. Motors convert the electricity back into mechanical form to drive machinery and appliances.

It must be remembered that all of the inductance properties discussed here for coils and transformers only apply to AC (alternating current). For DC, inductors act as wires with no special properties and transformers are just two separate, unconnected wires.

## TEST YOUR KNOWLEDGE #2

1. A diode has very high resistance when it is \_\_\_\_\_-biased.
2. Diodes whose turn-on energy is so high that light is generated are known as \_\_\_\_\_.
3. The transistor is best thought of as a current \_\_\_\_\_.
4. An \_\_\_\_\_ circuit is one that might have many resistors, diodes, capacitors and transistors on a single piece of silicon.
5. A transistor is \_\_\_\_\_ when the circuit resistances, not the transistor itself, are limiting the transistor's collector current.
6. Inductors have low resistance to \_\_\_\_\_ current and high resistance to \_\_\_\_\_ current.
7. Adding inductors in parallel \_\_\_\_\_ the inductance while adding inductors in series \_\_\_\_\_ the inductance.
8. Electrons not only have electric properties but also \_\_\_\_\_ properties.
9. Wrapping a coil around an iron bar \_\_\_\_\_ the inductance.
10. If the second coil in a transformer has half as many turns as the first coil, then the second coil will have \_\_\_\_\_ as much alternating current as the first coil.

(Answers are on page 5).

## EXPERIMENT #25: The Magnetic Bridge

Connect the wires according to the Wiring Checklist. You are using the antenna for the first time here but only as a low-value resistor (about  $10\Omega$ ); it has other properties that will be explained in later experiments. Press the switch several times. LED1 blinks when the switch is pressed and LED2 blinks when the switch is released.

Although the LED may blink in the same manner as the last experiment, the method is quite different. There is no wire connection across the transformer, its DC resistance is very high. When you press the switch there is a sudden surge of current (AC) through the inductor that magnetically creates a current on the other side of the transformer, lighting the LED. The current from the battery quickly settles after the initial surge (becomes DC) and the magnetic induction stops because the current is no longer changing, hence no current flows through the LED even though there is current on the

battery side of the transformer. When you release the switch the sudden drop in current through the transformer magnetically creates a new current on the other side of the transformer, but this time in the opposite direction so LED2 lights instead of LED1. Again, this current is brief and the LED only blinks. The transformer has many more turns (more inductance) on the LED side than on the battery side; this boosts the voltage to the LEDs (though it also lowers the current). If you reverse the transformer then you won't have enough voltage to turn on the LEDs.

You might think of a transformer as a magnetic bridge in electronics, since we use magnetism to cross a barrier that electricity cannot cross by itself. Transformers are mainly used for isolating and buffering different circuits from each other, and you will soon see some examples of this.

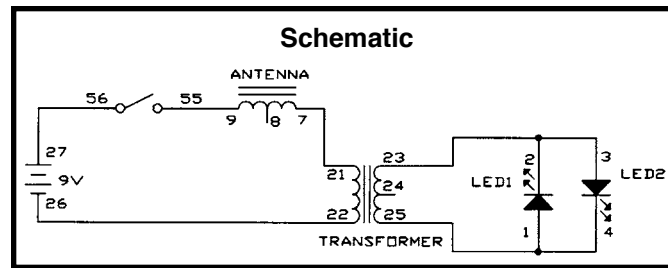

### Wiring Checklist:

- 27-to-56
- 55-to-9
- 7-to-21
- 22-to-26
- 2-to-3-to-23
- 1-to-4-to-25

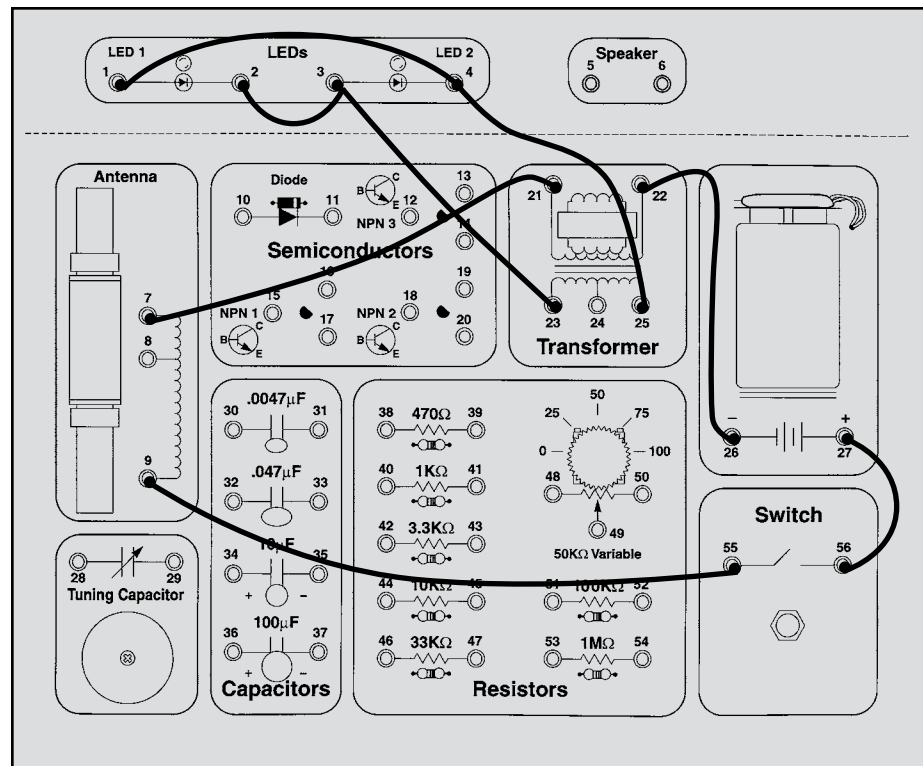

## EXPERIMENT #26: The Lighthouse

Connect the wires according to the Wiring Checklist. Notice that the transformer is being used as two coils (inductors) here. Also notice that transformer springs 23 and 24 are not connected although their wires cross in the schematic. Press the switch and hold it down for a while. The LED blinks every few seconds, like a tiny lighthouse!

Notice that the LED blinks at a constant rate. This circuit is called an **oscillator**. It uses **feedback**. Feedback is when you adjust the input to something based on what its output is doing. The collector signal is fed back to the base through a coil (part of the transformer) and the 100 $\mu$ F capacitor. If you disconnect this feedback path then the LED will be on continuously, because the

feedback is what turns the transistor on and off. The rate at which the transistor is turned on and off is called the frequency and is controlled by the resistor, capacitor, and coil in the circuit. You can speed up the frequency (the LED blink rate) by changing the resistor or capacitor to smaller values. Try replacing the 1M $\Omega$  resistor with the 100K $\Omega$  resistor and see what happens.

Feedback is necessary for this circuit to work, but in some cases it can be harmful. In an auditorium or concert hall you sometimes hear a microphone scream when it is located too close to the speaker. In this case the sound from the speaker is feeding back into the microphone.

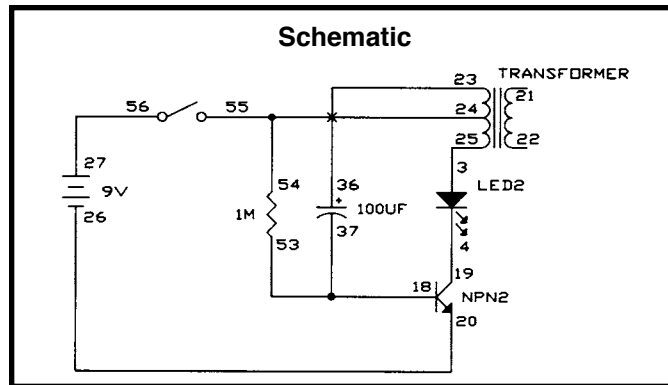

### Wiring Checklist:

- 27-to-56
- 54-to-55-to-24
- 23-to-36
- 37-to-53-to-18
- 19-to-4
- 3-to-25
- 20-to-26

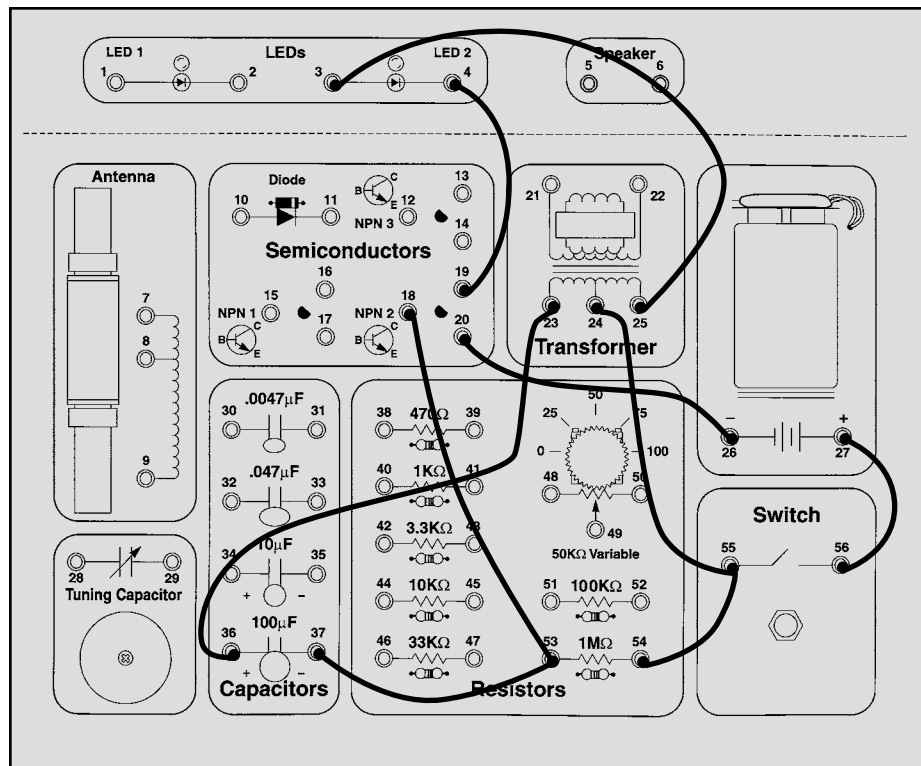

## EXPERIMENT #27: Electronic Sound

Now it's time to make some noise. To do this we need a **speaker**. A speaker converts electrical energy into sound. It does this by using the energy of an AC electrical signal to create mechanical vibrations. These vibrations create variations in air pressure, called sound waves, which travel across the room. You "hear" sound when your ears feel these air pressure variations. You need high current and low voltage to operate a speaker, so we will always use the transformer with the speaker. (Remember that a transformer converts high-voltage/low-current to low-voltage/high-current). We create an AC signal for the speaker using the oscillator circuit introduced in the last experiment, with minor changes. A speaker has a schematic symbol like this:

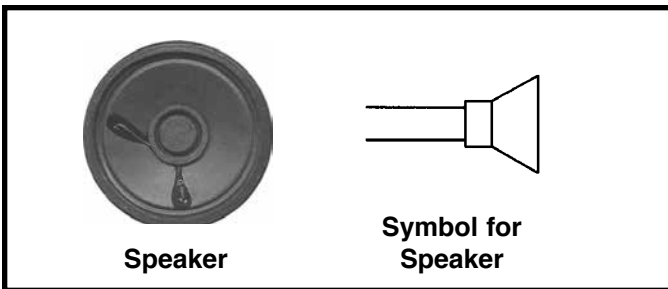

Connect the wires according to the Wiring Checklist. Notice that transformer springs 23 and 24 are not connected although their wires cross in the schematic. Also notice there are 4 resistors and 4 capacitors connected to the 3.3KΩ resistor and 2 loose wires connected to the transformer. Connect the transformer to one resistor and one capacitor at a time, then press the switch and listen. All the combinations are listed below, you don't need to try all of them but try some and see if there is a pattern in the frequency or **pitch** (a term used in music) of the sound. Record a few comments about the sound you hear.

You may start to see the same thing we told you about the blinking LED frequency - that the frequency increases when you lower the resistance or capacitance. It also increases if you lower the inductance, but you don't have any other inductors you can substitute.

Oscillators are among the most important circuits in electronics and most of your remaining experiments will use an oscillator of some form. Although the oscillator circuits used here are simple ones, some oscillators can be the most difficult circuits to design.

	10KΩ	33KΩ	100KΩ	1MΩ
.0047μF		<del></del>		
.047μF				
10μF				
100μF				

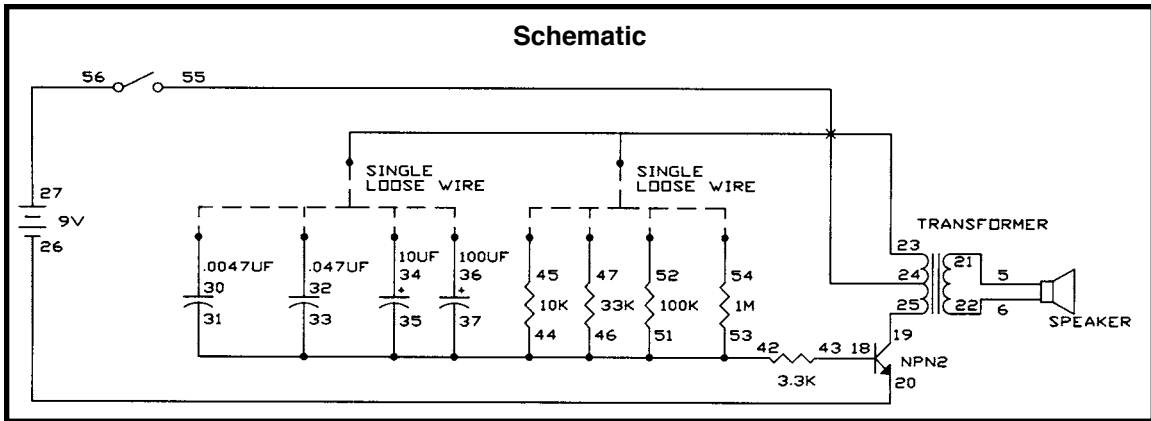

**Wiring Checklist:**

- 27-to-56
- 55-to-24
- 25-to-19
- 20-to-26
- 18-to-43
- 5-to-21
- 6-to-22
- 42-to-31-to-33-to-35-to-37-to-44-to-46-to-53-to-51
- unconnected-to-23-to-unconnected (2 loose wires)

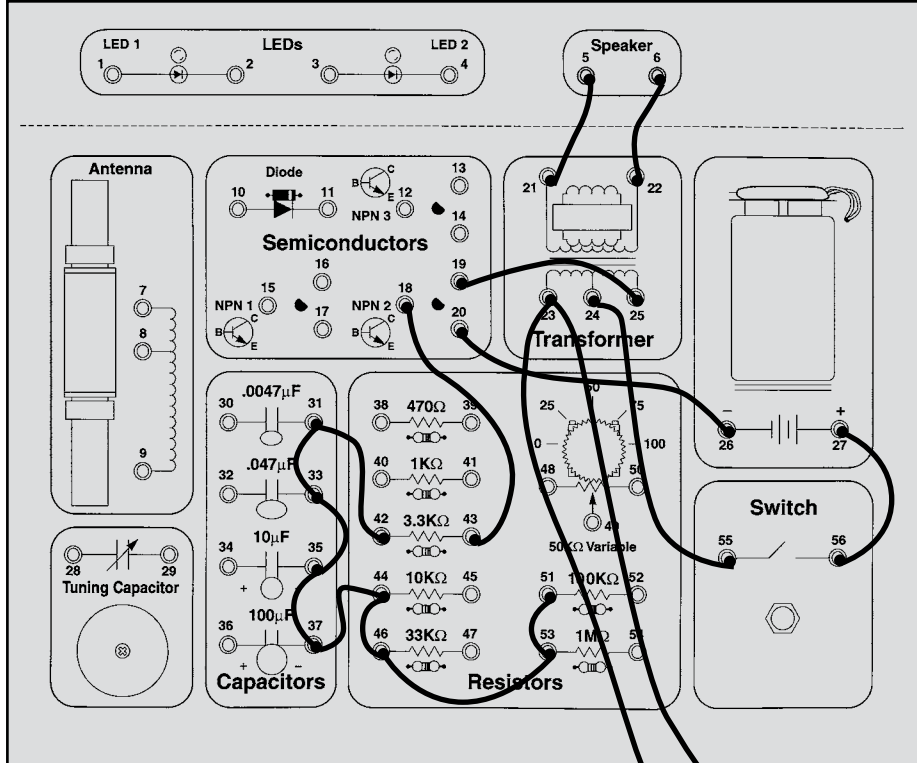

Loose  
Wires

## EXPERIMENT #28: The Alarm

This circuit is unusual in that you turn it on by disconnecting a wire and turn it off by connecting the wire. Connect the wires according to the Wiring Checklist and schematic, including a long wire as the "trip" wire. Notice that there is no sound. Now disconnect the trip wire and you hear a sound, an alarm.

This type of circuit is used to detect burglars or other intruders. If you use a longer trip wire, you can place it across a doorway or window and when someone goes through the doorway or window they will trip on the wire (disconnecting it) and the alarm will sound. This is how professional burglar alarms work, although some use beams of light across the doorway or window instead of wire for the "trip" mechanism. The trip wire could also alert your local police station instead of turning on the alarm here.

This circuit is the same oscillator circuit you just used except that the trip wire was added. The trip wire creates a "short circuit" across the transistor base, so no current flows into the base and the transistor stays off. Disconnecting the trip wire eliminates the short and the oscillator works normally.

If you like, you can adjust the loudness of the alarm by replacing the 3.3K $\Omega$  resistor with the variable resistor.

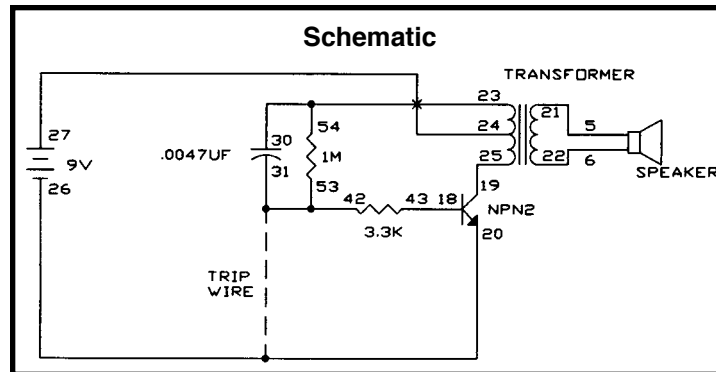

### Wiring Checklist:

- 27-to-24
- 19-to-25
- 18-to-43
- 5-to-21
- 6-to-22
- 54-to-23-to-30
- 31-to-42-to-53
- 20-to-26
- 26-to-53 (use a long wire, this will be referred to as the "trip" wire)

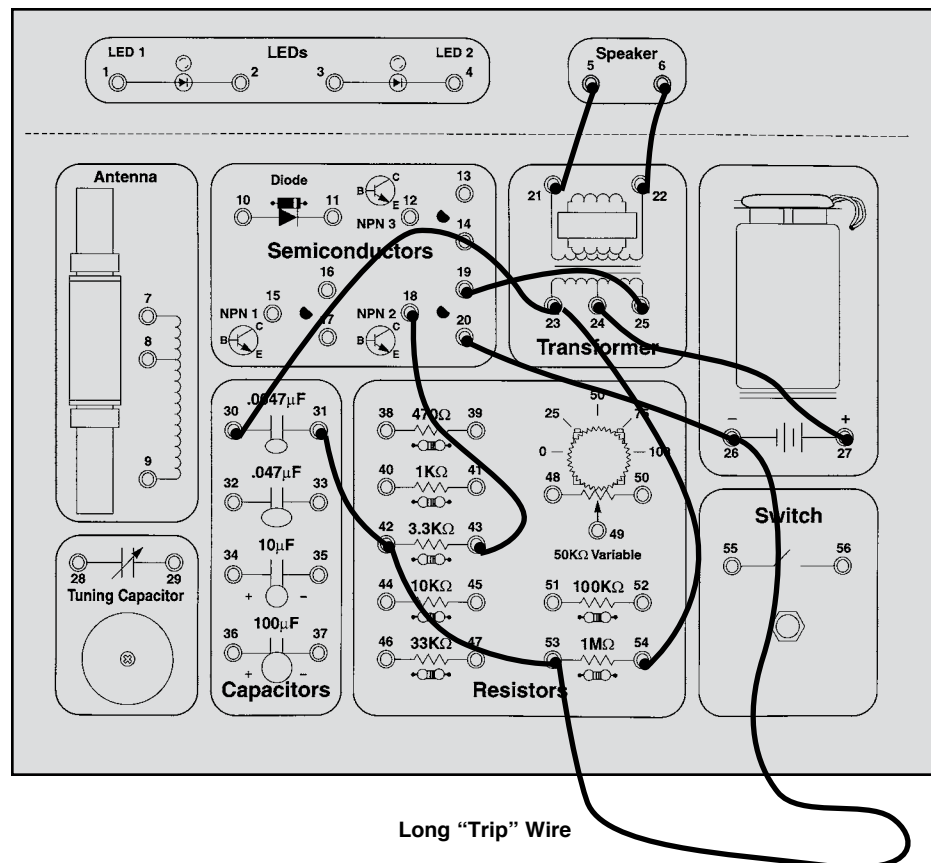

# EXPERIMENT #29: Morse Code

The forerunner of today's telephone system was the telegraph, which was widely used in the latter half of the 19th century. It only had two states – on or off (that is, transmitting or not transmitting), and could not send the range of frequencies contain in human voices or music. A code was developed to send information over long distances using this system and a sequence of dots and dashes (short or long transmit bursts). It was named Morse Code after its inventor. It was also used extensively in the early days of radio communications, though it isn't in wide use today except in amateur radio ("ham" radio). It is sometimes referred to in Hollywood movies, especially Westerns.

This is the same oscillator circuit that you have been using. Connect the wires according to the Wiring Checklist. Press the switch in long and short bursts to make a sound pattern representing the dots and dashes shown in the table above. You can use Morse Code and this circuit to send secret messages to friends in hearing distance without others knowing what you're saying. If the sound bothers others in the room then you may send Morse Code messages using flashes of light instead. Use the same circuit as you used in Experiment 13 (The Electronic Switch) and press the switch in the manner shown here. During World War II Navy ships sometimes communicated by flashing Morse Code messages between ships using searchlights (they did this because radio transmissions might reveal their presence or position to the enemy).

Morse Code			
A	· -	P	· - - - ·
B	- - - ·	Q	- - - - -
C	- - · -	R	· - · -
D	- · - ·	S	· · -
E	·	T	-
F	· · - ·	U	· - -
G	- - ·	V	· · - -
H	· · · ·	W	- · - -
I	· ·	X	- · - ·
J	· - - -	Y	- · - - -
K	- · -	Z	- - - ·
L	· - · -	Period	- - - - -
M	- -	Comma	- - - · -
N	- ·	Question	· - - - ·
O	- - -		

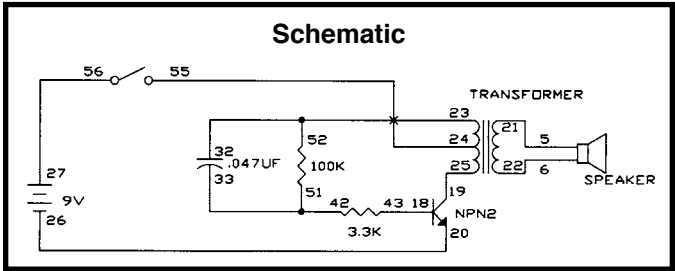

Wiring Checklist:

- 27-to-56
- 55-to-24
- 19-to-25
- 18-to-43
- 5-to-21
- 6-to-22
- 52-to-23-to-32
- 33-to-42-to-51
- 20-to-26

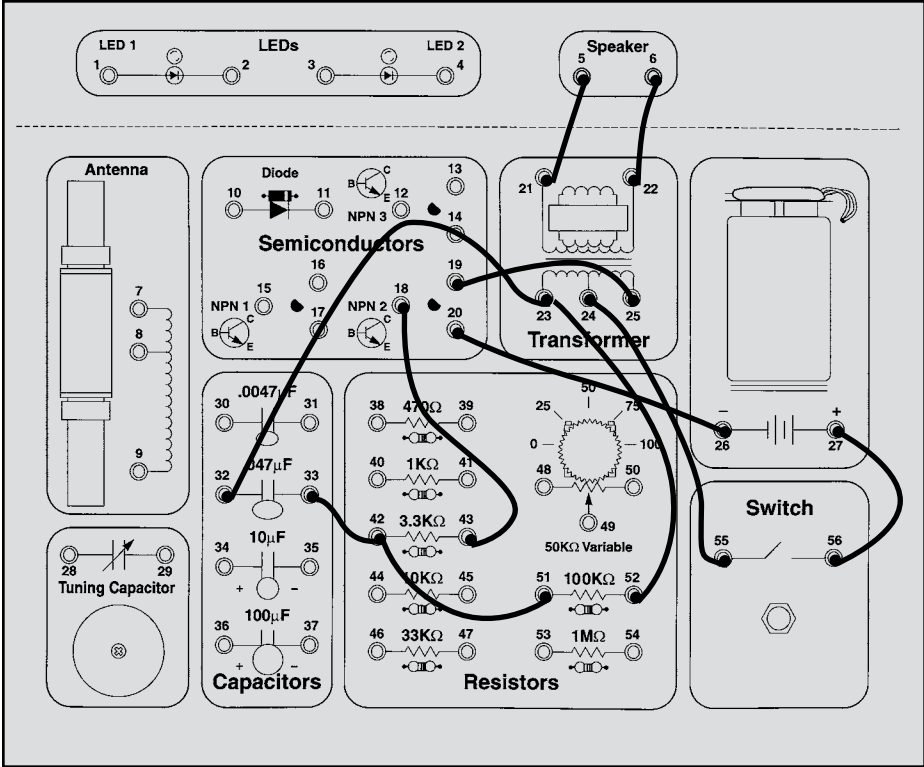

## EXPERIMENT #30: Siren

Connect the wires according to the Wiring Checklist and press the switch. It makes a siren sound.

You saw earlier how you could change the frequency (pitch) of the oscillator by changing the oscillator's resistance. Well this is basically the same oscillator circuit you've been using except that now we are electronically varying the oscillator's resistance. The large  $1M\Omega$  resistor and  $10\mu F$  capacitor cause the base voltage (and hence base current) on transistor NPN 1 to

rise slowly. As the base current slowly increases, NPN 1's collector current also increases slowly (though it is always much higher than the base current). NPN1 is now limiting the current just as a resistor does! Similar effects occur after you release the switch and the  $10\mu F$  slowly discharges.

If you like you can make the sound louder. Move the wire from spring 18 to spring 40, and add a wire from spring 41 to spring 18.

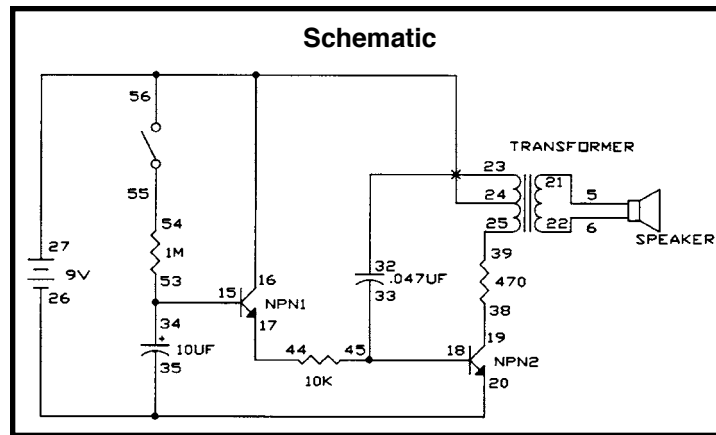

### Wiring Checklist:

- 5-to-21
- 6-to-22
- 25-to-39
- 38-to-19
- 23-to-32
- 18-to-33-to-44
- 45-to-17
- 15-to-34-to-53
- 54-to-55
- 35-to-26-to-20
- 16-to-24-to-27-to-56

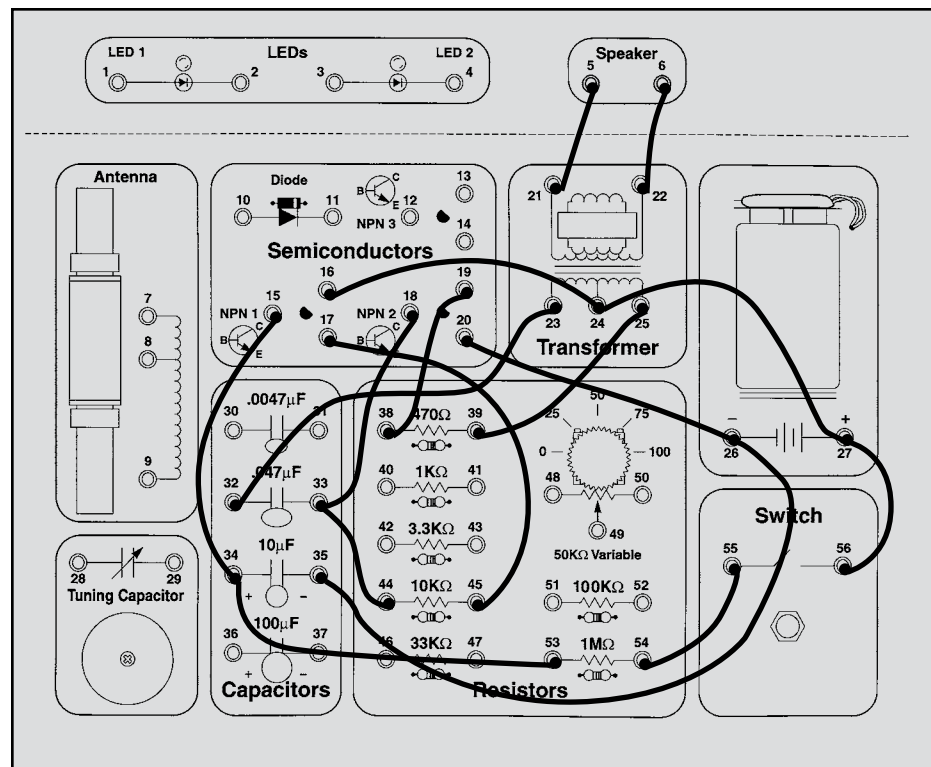



## EXPERIMENT #31: Electronic Rain

Connect the wires according to the Wiring Checklist and press the switch. You hear a sound like raindrops. The variable resistor (VR) knob controls the rain, turn it to the right to make a drizzle and turn to the left to make the rain come pouring down. If you find it inconvenient to turn the VR knob while pressing the switch then just connect a wire across the switch.

Do you know how this circuit works? Remember that as you lower the oscillator's resistance the frequency increases, and obviously the VR controls the resistance. What would happen if you replaced the 10KΩ resistor with the 100KΩ? Try it. The rain is now very slow, and it sounds more like a leaky faucet than raindrops.

You can experiment with changing other component values if you like.

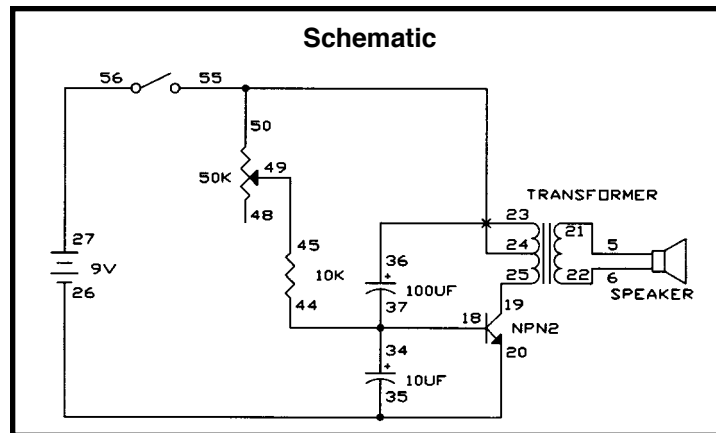

### Wiring Checklist:

- 27-to-56
- 50-to-55-to-24
- 19-to-25
- 5-to-21
- 6-to-22
- 23-to-36
- 18-to-34-to-37-to-44
- 45-to-49
- 20-to-26-to-35

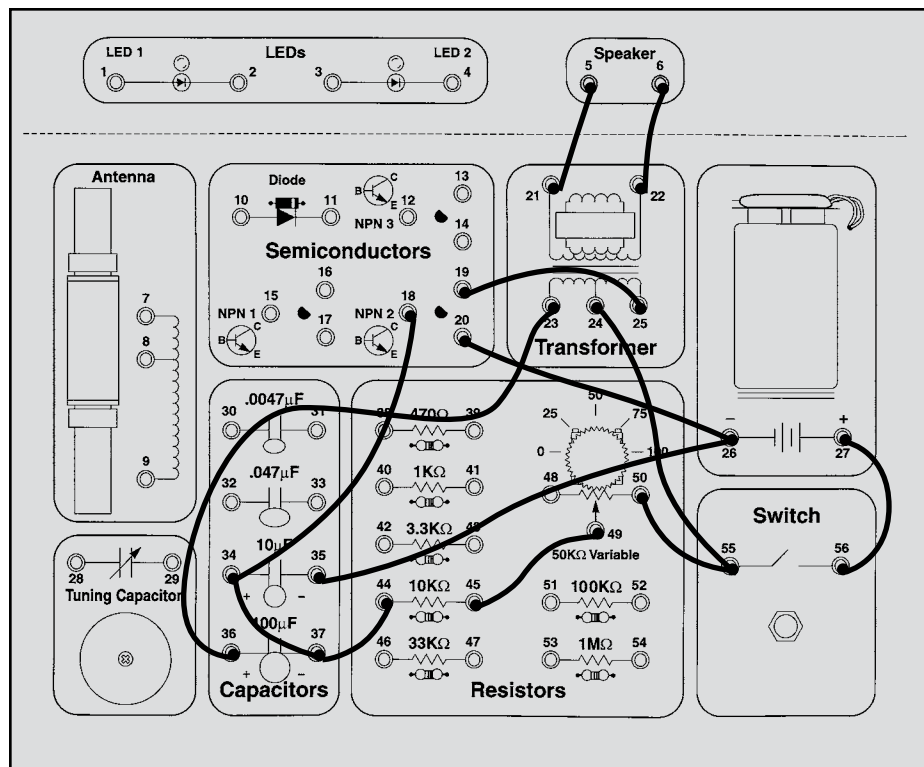

## EXPERIMENT #32: The Space Gun

Connect the wires according to the Wiring Checklist and press the switch several times quickly. You hear a sound like a space gun in the movies. You can adjust the “gun” sound using the variable resistor. If you find it inconvenient to turn the VR knob while pressing the switch then just connect a wire across the switch.

Do you know how this circuit works? It’s basically the same as the last circuit except for the  $10\mu\text{F}$  capacitor, which instantly charges up when you press the switch and then discharges by powering the circuit for a few seconds after you release the switch.

You can experiment with changing component values if you like.

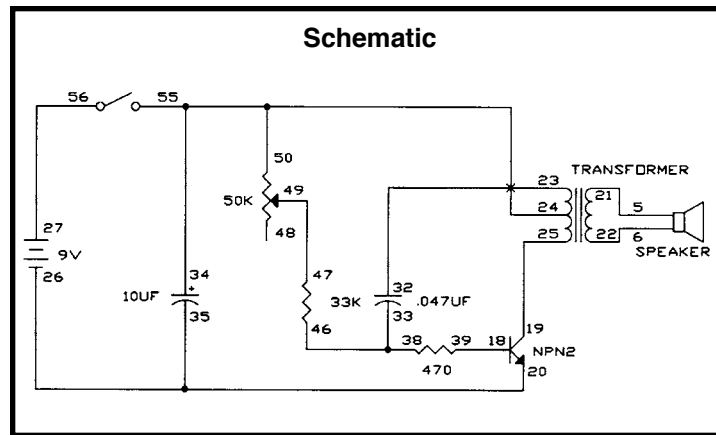

### Wiring Checklist:

- 27-to-56
- 34-to-55-to-50-to-24
- 19-to-25
- 5-to-21
- 6-to-22
- 23-to-32
- 18-to-39
- 38-to-33-to-46
- 47-to-49
- 20-to-26-to-35

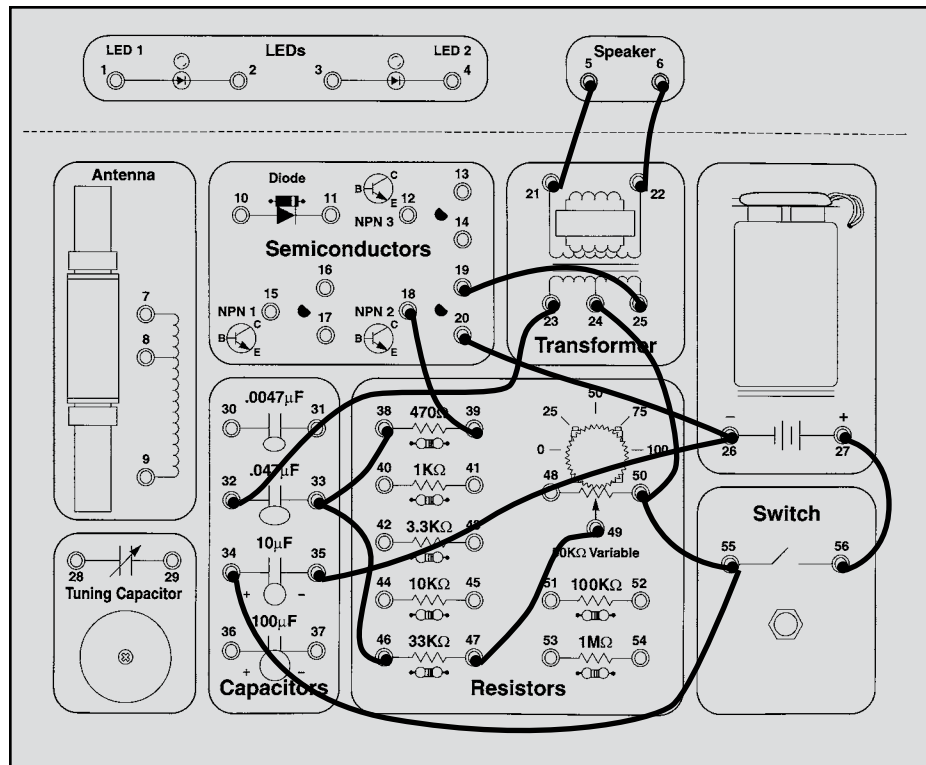

## EXPERIMENT #33: Electronic Noisemaker

Connect the wires according to the Wiring Checklist, connecting the battery wire last since it will turn the circuit on. Press the switch several times quickly. Then turn the variable resistor knob to change the frequency of the sounds.

Do you understand what's happening when you press the switch? You increase the oscillator capacitance by putting the  $.0047\mu\text{F}$  in parallel with the  $.047\mu\text{F}$ , and this lowers the oscillator frequency.

As usual you can experiment with changing component values if you like.

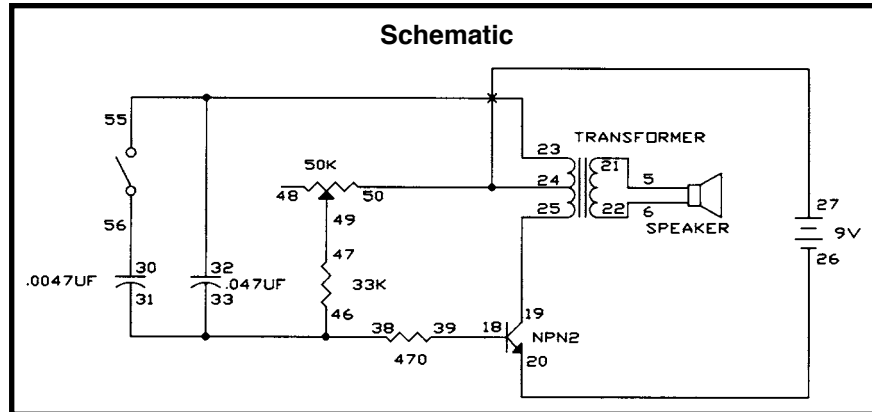

### Wiring Checklist:

- 19-to-25
- 5-to-21
- 6-to-22
- 30-to-56
- 49-to-47
- 46-to-33-to-31-to-38
- 18-to-39
- 20-to-26
- 27-to-50-to-24

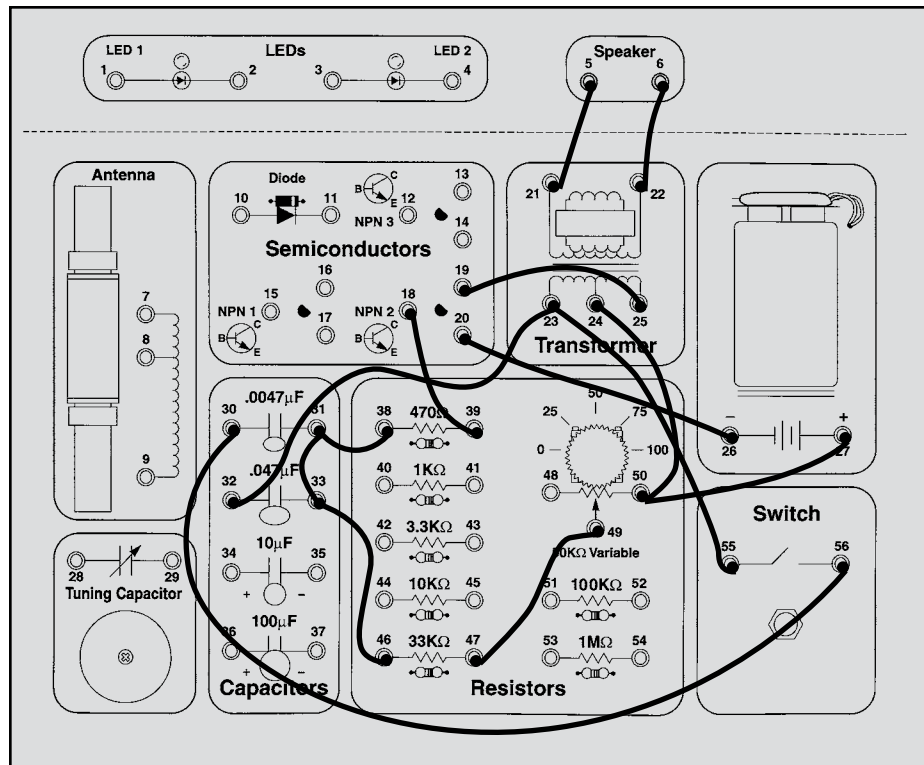

# EXPERIMENT #34: Drawing Resistors

You need some more parts to do this experiment, so you're going to draw them. Take a pencil (No. 2 lead is best but other types will also work), **SHARPEN IT**, and fill in the 4 rectangles you see below. You will get better results if you **place a hard, flat surface between this page and the rest of this booklet** while you are drawing. **Press hard** (but don't rip the paper) and **fill in each several times** to be sure you have a **thick, even layer of pencil lead** and try to avoid going out of the boundaries.

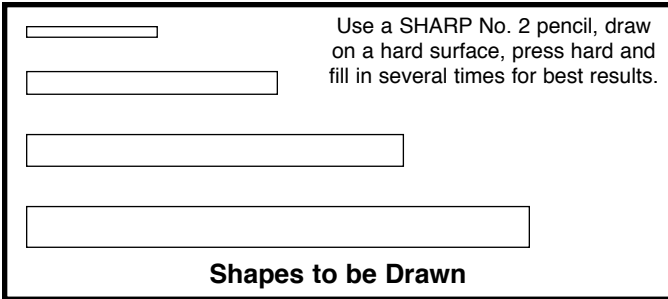

Actually, your pencils aren't made out of lead anymore (although we still call them "lead pencils"). The "lead" in your pencils is really a form of carbon, the same material that resistors are made of. So the drawings you just made should act just like the resistors in your Electronic Playground.

Connect the wires according to the Wiring Checklist. It's the same basic oscillator circuit you have been using. Take the two loose wires and touch them to opposite ends of the smallest rectangle you drew, you should hear a sound like an alarm. Note: you may get better electrical contact between the wires and the drawings if you wet

the wires with a few drops of water or saliva. What kind of sound do you think you'll get with the other drawings? (Hint: think about how resistors operate in series and parallel combinations, or think in terms of the water pipes). Now touch the loose wires to opposite ends of the other rectangles you drew (you may need to wet the wires again) and see if you were right. You can also slide one of the wires along the drawing and see how the sound changes.

Making the drawn resistors longer should increase the resistance (resistors in series or longer water pipes) while making them wider should reduce the resistance (resistors in parallel or larger water pipes). So all 4 rectangles should produce the same sound, though you will see variations due to how thick and evenly you filled in the rectangles, and exactly where you touch the wires. If your 4 shapes don't sound similar then try improving your drawings.

Be sure to wash your hands after this test, unless you're going on to Experiment 35 now.

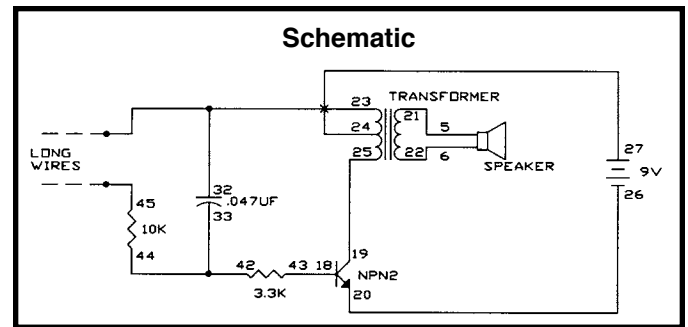

## Wiring Checklist:

- 19-to-25
- 5-to-21
- 6-to-22
- 20-to-26
- 18-to-43
- 23-to-32-to-unconnected (the unconnected wire should be long)
- 33-to-42-to-44
- 45-to-unconnected (the unconnected wire should be long)
- 27-to-24

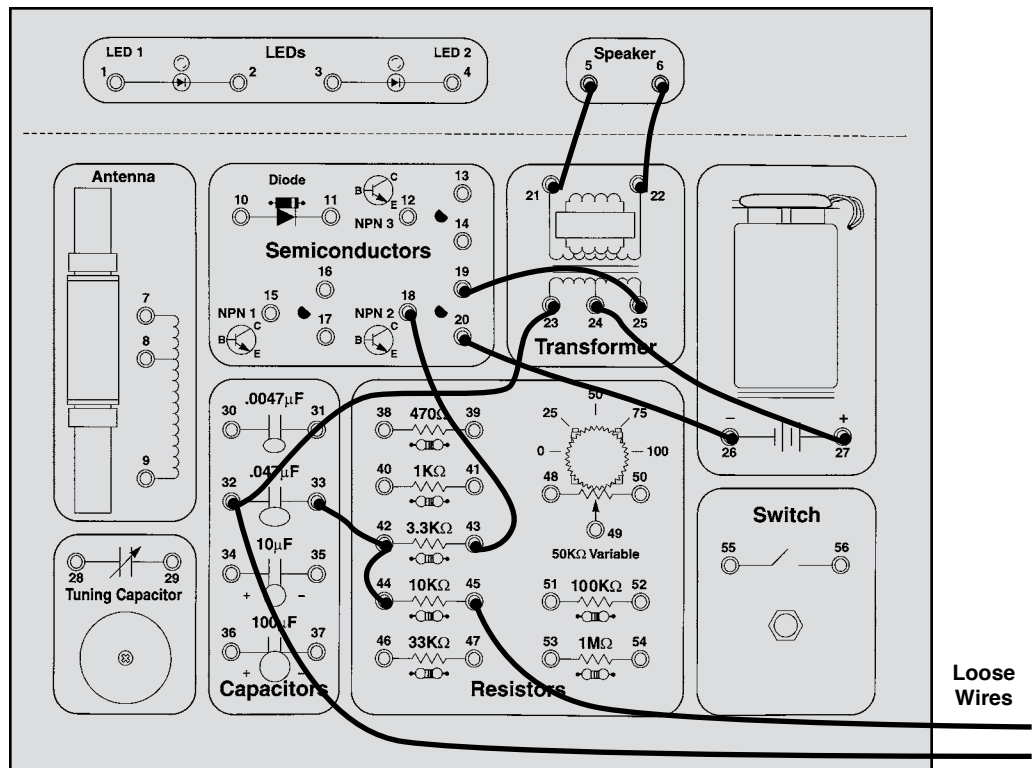

## EXPERIMENT #35: Electronic Kazoo

Now it's time to make your own music. This experiment will use the (almost) same circuit as the last one, so there is no schematic or Wiring Checklist. The only difference is that you will draw a new shape. A Kazoo is a musical instrument that is like a one-note flute, and you change the pitch (frequency) of the sound by moving a plunger up and down inside a tube.

As before, take a pencil (No. 2 lead is best but other types will also work), **SHARPEN IT** again, and fill in the shape

you see below. For best results **SHARPEN IT** again, **place a hard flat surface between this page and the rest of this booklet** while you are drawing, **Press hard** (but don't rip the paper), **fill in each several times** to be sure you have a **thick, even layer of pencil lead**, and try to avoid going out of the boundaries. **Where the shape is just a line, draw a thick line and go over it several times.** The black ink in this manual is an insulator just like paper, so you have to write over it with your pencil.

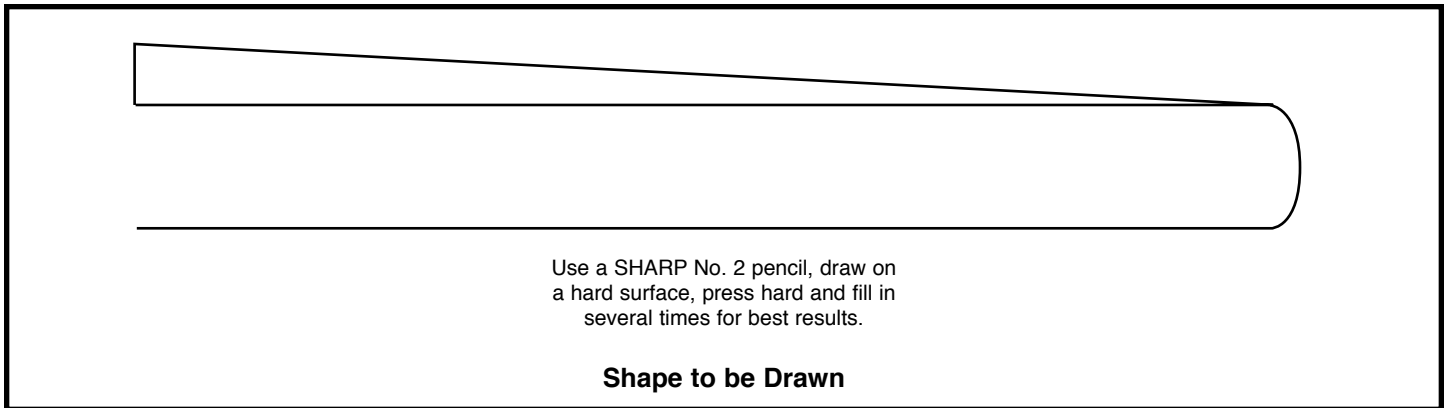

Take one loose wire and touch it to the widest part of this shape, at the upper left. Take the other loose wire and touch it just to the right of the first wire. You should hear a high-pitch sound. How do you think the sound will change as you slide the second wire to the right? Do it, slowly sliding all the way around to the end. The sound changes from high frequency to low frequency, just like a kazoo. Note: you may get better electrical contact between the wires and the drawings if you wet the wires with a few drops of water or saliva.

This circuit is nearly the same as for Experiment 27 (Electronic Sound), so you can use the notes you took there to estimate what the resistance is at various points along your kazoo.

Be sure to wash your hands after this test, unless you're going on to Experiment 36 now.

## EXPERIMENT #36: Electronic Keyboard

This experiment will use the (almost) same circuit as the last one, so there is no schematic or Wiring Checklist. The only difference is that you will draw a new shape.

As before, take a pencil (No. 2 lead is best but other types will also work), **SHARPEN IT** again, and fill in the shape you see below. For best results **SHARPEN IT again, place a hard flat surface between this page and the**

**rest of this booklet** while you are drawing, **Press hard** (but don't rip the paper), **fill in each several times** to be sure you have a **thick, even layer of pencil lead**, and try to avoid going out of the boundaries. **Where the shape is just a line, draw a thick line and go over it several times.** The black ink in this manual is an insulator just like paper, so you have to write over it with your pencil.

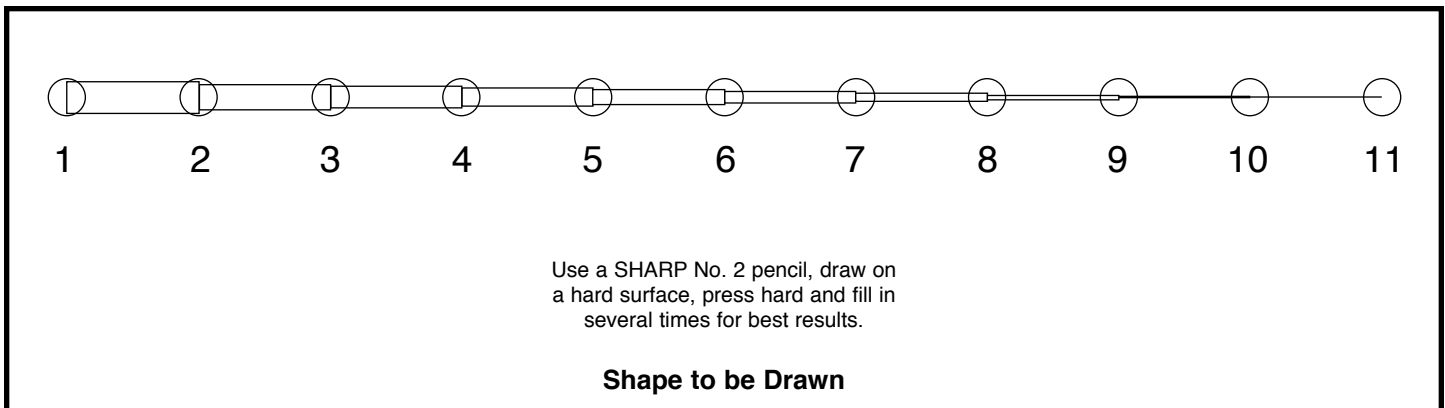

Take one loose wire and touch it to the left circle. Take the other loose wire and touch it to each of the other circles. The various circles produce different pitches in the sound, like notes. Since the circles are like keys on a piano, you now have an electronic keyboard! See what kind of music you can play with it. Note: you may get better electrical contact between the wires and the drawings if you wet the wires with a few drops of water or saliva.

Now take one loose wire and touch it to the right circle (#11). Take the other wire and touch it to the circles next to the numbers shown below, in order:

7 - 5 - 1 - 5 - 7 - 7 - 7  
5 - 5 - 5  
7 - 7 - 7  
7 - 5 - 1 - 5 - 7 - 7 - 7 - 7 - 5 - 5 - 7 - 5 - 1

Do you recognize this nursery rhyme? It is "Mary Had a Little Lamb".

By now you see that you can draw any shape you like and make electronic sounds with it. Experiment on your own as much as you like. The circuit here is nearly the same as for Experiment 27 (Electronic Sound), so you can use the notes you took there to estimate what the resistance is at various points along your keyboard or any other shapes you make.

Be sure to wash your hands after this test.

# EXPERIMENT #37: Fun with Water

Connect the wires according to the Wiring Checklist. Initially the two loose wires are unconnected so there is no sound. Now touch each wire with fingers from different hands, you should hear a low-frequency sound. (Wetting your fingers with water or saliva will make better electrical contact). You are using your body as an electrical component, just as you did in Experiment 19 (Finger Touch Lamp). If you like you may make the sound louder by removing the wire from spring 18 (trans base) and connecting it to spring 42 (3.3KΩ), then connect a wire from spring 43 (3.3KΩ) to spring 18.

Now take a small cup (make sure it isn't made of metal), fill it half way with water, and place the two wires into the water but without touching each other. The sound will now have a much higher frequency because your drinking water has lower resistance than your body. Now, with the wires still in the water making noise, add some table salt to the water and stir to dissolve the salt. You should hear the frequency increase as you do this.

This circuit makes a good water detector. You could use it as a warning alarm in case your house starts to flood during a storm. Or you could use the frequency of the sound as a water saltiness indicator.

You can also make a water kazoo. Pour a small amount of water on a table or the floor and spread it with your finger into a long line. Place one of the wires at one end and slide the other along the water. You should get an effect just like the kazoo you drew with the pencil, though the frequency will probably be different.

You've seen how adding salt to water decreases its resistance. So would it surprise you to know that pure water (distilled water) has very high resistance? The drinking water you are using here has small amounts of minerals in it, which decrease its resistance just like salt does. Your body conducts electricity because your body is mostly water, with many things mixed in. When salt dissolves in water it breaks up into particles called ions, which are electrically charged. The ions make it easier for electrons to travel through the water, similar to how adding impurities makes it easier for electrons to flow through semiconductors. Their overall effect is that the resistance of the water is reduced. If you have some distilled water in your house, try using it with this test.

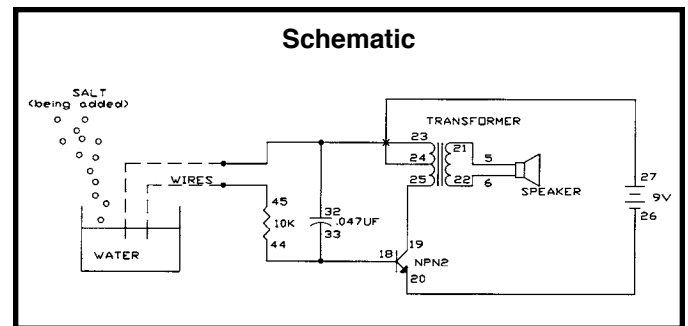

### Wiring Checklist:

- 19-to-25
- 5-to-21
- 6-to-22
- 20-to-26
- 23-to-32-to-unconnected (the unconnected wire should be long)
- 18-to-33-to-44
- 45-to-unconnected (the unconnected wire should be long)
- 27-to-24

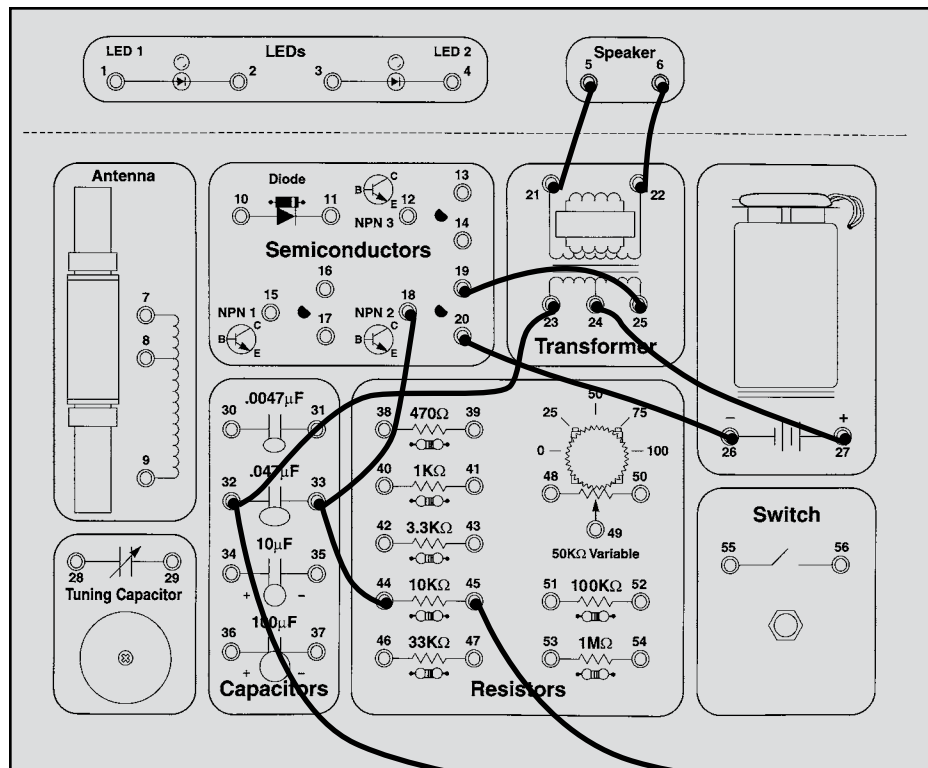

## EXPERIMENT #38: Transistor Radio

Back in Experiments 24 (Anti-Capacitor) and 25 (Magnetic Bridge) we talked about how an electric current through a coil creates a magnetic field and how this magnetic field can be used to “bridge” air gaps in a transformer. What if the transformer air gap was larger, perhaps a few inches? The distant coil would still pick up some of the energy, but not much. If the original (“transmitting”) coil and current through it were much larger, then the electromagnetic field from it could still be picked up by a “receiving” coil and produce a small current even if the distance was many miles. This is the concept of radio, which uses electromagnetic waves to send information through the air. The coils used for transmitting and receiving these signals are called **antennas**. Today the air around us is full of radio transmissions for things such as music, television, cellular phones, aircraft navigation, communication with probes in outer space, radio-controlled toys, and thousands of other uses. The Federal Government makes sure that all of these uses operate on different frequencies so that they don’t interfere with each other. A wide range of schemes are used for encoding the radio signals with the information being sent. These are called **modulation**. You’ve probably heard of AM and FM radios. These stand for Amplitude Modulation and Frequency Modulation.

There are many different radio signals floating around, but we only want to listen to one. Think of this as being in a large, crowded room and trying to talk to someone on the other side. We solve this by connecting our antenna to a capacitor in sort of an inductor-capacitor oscillator. Remember from Experiment 24 that an inductor passes DC (low frequencies) and blocks AC (high frequencies) while a capacitor does the opposite. By combining these two components we can “filter” out a small range of frequency that we will listen to. By varying the capacitance (using a **tuning capacitor** like the one included in your Electronic Playground) we can adjust or “tune” the range of frequency that we are listening to. The tuning dial on all AM and FM radios is a variable capacitor just like yours. After filtering out the undesired radio frequencies we amplify the remaining signal using a transistor amplifier like the one used in Experiment 16, decode the modulation into the original **audio** signal (electrical energy representing voice or music), and produce sound with a speaker.

The antenna you will use is a 50 $\mu$ H and a 800 $\mu$ H coil connected together and wrapped around an iron bar. The variable capacitor varies from 50 to 200pF (which is .00005 to .0002 $\mu$ F). Notice that these values are much smaller than the transformer and the other capacitors you have; that is why they have not been used in any previous experiments. Their symbols are:

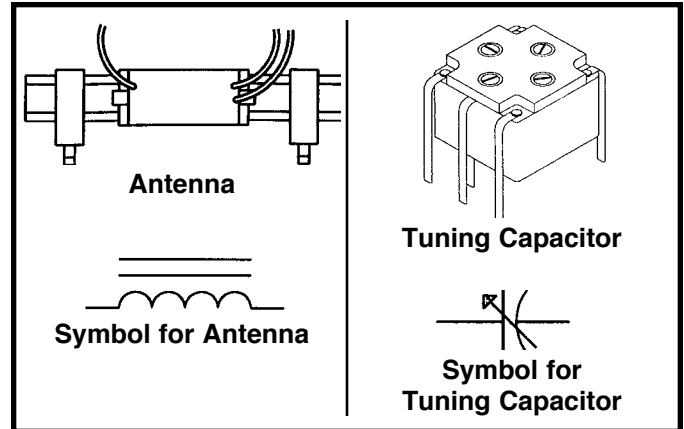

You will now build an AM radio receiver. Connect the wires according to the Wiring Checklist, connecting the battery wire last since this will turn on the circuit. You will get better circuit performance if you keep your wires short, so don’t use longer wire lengths than you need to. This is because at high frequencies long wires start to act like small inductors. AM radio uses a frequency range of 500 to 1600 KHz, where these effects are just starting to become noticeable. After connecting the last wire, turn your variable resistor all the way to the left. This part acts as the speaker loudness control, turn it down (to the right) if your sound is too loud. Now adjust your tuning capacitor, turning it slowly. You should be able to hear a few local radio stations. Although this radio uses the same types of circuits as AM radios sold in stores, this is a very simple radio receiver. Take a look inside an old AM radio in your house, you’ll see a lot more components. So don’t expect to get as good of performance as with radios sold in stores.

If you turn the tuning capacitor slowly you should receive several stations. If not, try walking around your house or outside with your Playground. This may give you better radio reception. Or you can connect a wire from battery spring 26 to a water pipe or other electrical “ground”. Also check your wiring, as this circuit is more complicated than most that you have built.

Take a look at the schematic. The antenna and tuning capacitor for tuning are on the left. Transistor NPN1 amplifies the received radio signal using its current gain. The diode and .0047 $\mu$ F capacitor are a simple Amplitude Modulation detector, converting the radio signal back to the original audio signal. The audio is amplified using NPN2’s current gain and converted into sound by the speaker.



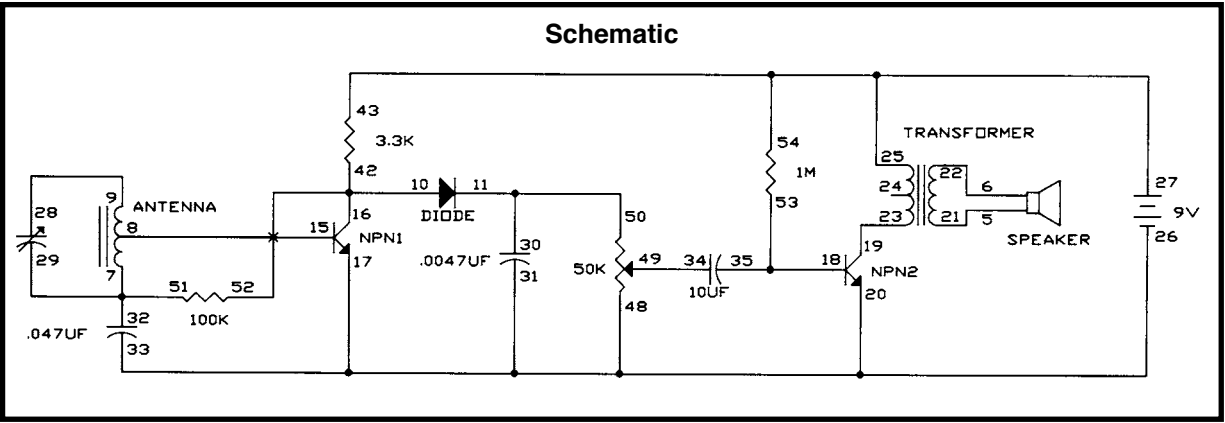

**Wiring Checklist:**

- 28-to-9
- 8-to-15
- 7-to-29-to-32-to-51
- 52-to-42-to-16-to-10
- 33-to-31-to-17-to-20-to-48-to-26
- 11-to-30-to-50
- 49-to-34
- 53-to-35-to-18
- 19-to-23
- 5-to-21
- 6-to-22
- 43-to-54-to-27-to-25

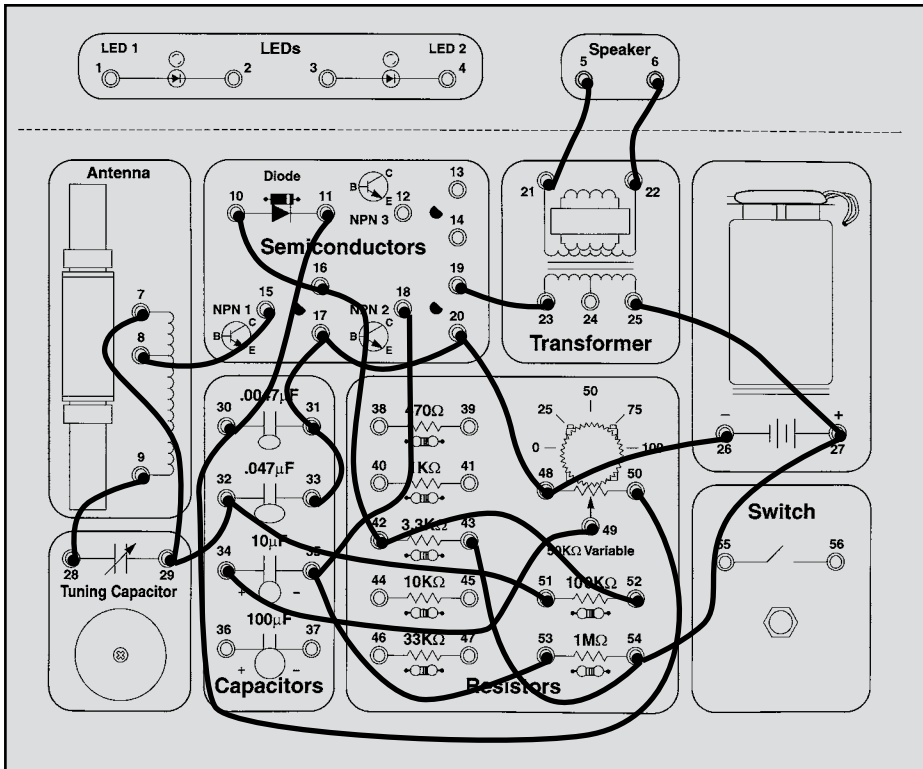

## EXPERIMENT #39: Radio Announcer

Now that you've built an AM receiver, how about building an AM transmitter? Ever wanted to be a radio announcer? You're about to get your chance. Note: you need an AM radio for this experiment.

Connect the wires according to the Wiring Checklist, connecting the battery wire last since this will turn on the circuit. As in the last experiment you will get better circuit performance if you keep your wires short, so don't use longer wire lengths than you need to.

Take an AM radio you have in your home, turn it on, extend its antenna, and place it next to your Electronic Playground. Tune it to the low end of the AM frequency range or somewhere near the low end where there is only static and no radio station. Now slowly adjust your variable capacitor until you hear the static quiet down or you hear a hum instead. This indicates to you that your radio is receiving the transmitted signal from your Playground, so both must be on the same frequency. Tap the cardboard panel near the speaker, you should hear this on the radio. Turn the radio volume control up a little if you don't hear it at first. If you can't get your radio and Playground to be on the same frequency then try tuning the radio to a different frequency (stay near the low end of the radio's tuning range) and try again. The AM transmitter circuit you are using is a very simple one and it will not operate across the entire range of AM radio frequencies. Your radio may have been tuned to a frequency that your transmitter can't reach. You can also tune your radio while tapping near the speaker. When you hear the tapping then your Playground and radio are on the same frequency (if this happens to be where an AM station exists then tune Playground and radio to the nearest static spot). If you still can't get this to work then check your circuit wiring. This is the most complex circuit you will build, and it is easy to make wiring errors.

Now talk into the speaker, keeping your mouth close to it. You should hear yourself on the radio! Turn up your radio volume control or shout if you don't hear yourself at first. You can also adjust your variable capacitor slightly to make sure you are tuned for best transmission.

In this experiment the speaker is being used as a microphone. A microphone is the opposite of a speaker, converting sound waves into electrical energy by sensing the variations in air pressure. (Recall from Experiment 27 that sound waves are variations in air pressure). The mechanical construction of the speaker allows it to also be used as a microphone, though it is more efficient as a speaker than as a microphone. If your voice didn't sound very clear on the radio, it is probably because of the speaker's limitations as a microphone. The transformer is used with the speaker as before.

The circuit is complex but advanced students may want to take a look at the schematic. The signal from the speaker (microphone) and transformer is applied to a high gain amplifier built around NPN2. This is the standard application of the transistor circuit you used in Experiment 16. The four resistors turn on the transistor but do not saturate it. The circuit built around transistor NPN1 is an oscillator, similar to the ones you have been using only higher in frequency. It uses the antenna as its inductor instead of the transformer, uses the variable capacitor to adjust the frequency, and it uses four resistors (including the 3.3K $\Omega$ ) to turn on the transistor without saturating it. It also gets its power from the output of the NPN2 circuit instead of directly from the battery. This is how the high-frequency oscillator is amplitude modulated to carry your voice to the radio. Part of the oscillator energy is transferred into the air at the antenna.

Now you can use this circuit to be a radio announcer or DJ!

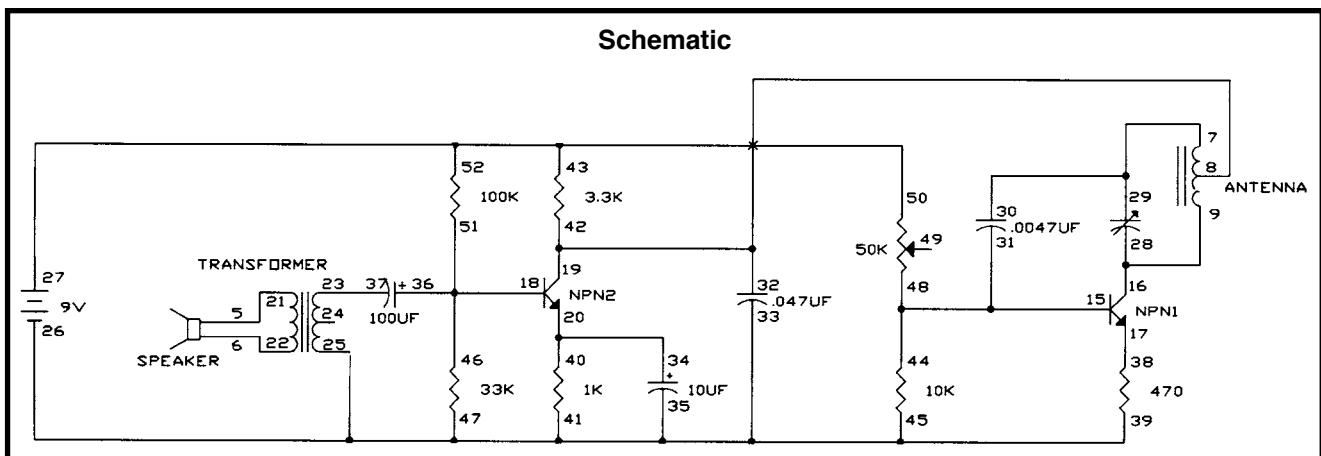

### Wiring Checklist:

- 25-to-26-to-47-to-45-to-41-to-39-to-33-to-35
- 28-to-9-to-16
- 17-to-38
- 7-to-30-to-29
- 15-to-31-to-44-to-48
- 8-to-32-to-42-to-19
- 20-to-40-to-34
- 18-to-51-to-46-to-36
- 37-to-23
- 5-to-21
- 6-to-22
- 43-to-52-to-50-to-27

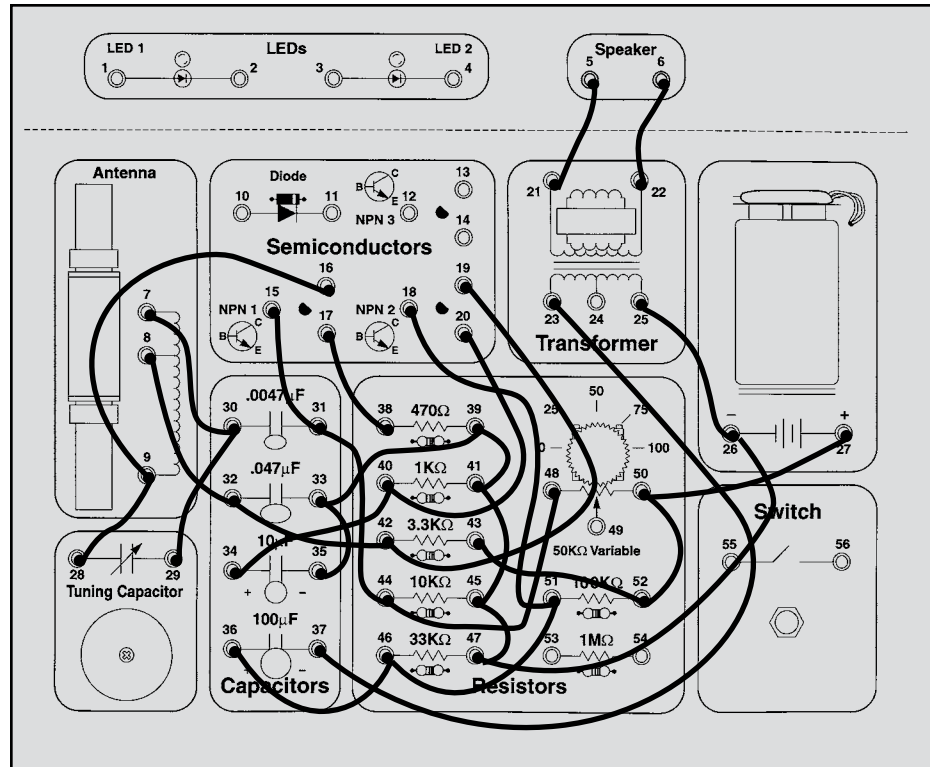

## EXPERIMENT #40: Radio Jammer

The circuit you have just built as an AM radio transmitter also has other applications. There is no schematic or Wiring Checklist here because we are using the same circuit.

Can you think of a way to use this circuit as an AM radio jammer? Here's how. Place your AM radio next to your Electronic Playground and tune it to a local AM radio station that is close in frequency to where the last experiment operated (at the low end of the radio's tuning range). Now adjust the variable capacitor to place your AM transmitter on the same frequency. When you've done this you will hear a hum or no sound at all instead of the radio station. If you can't get this to work then you probably picked a radio frequency that your AM transmitter can't reach, as we discussed in the last experiment. Pick a different radio station and try again.

So now you have an AM radio jammer. This works because the signal from your transmitter is stronger than the signal from the local radio station and "drowns it out" the same way someone standing next to you yelling makes it hard to hear somebody else talking to you softly. You can test the range of your jammer by moving your Playground away from the radio until you can hear the radio station again. And note that your jammer range depends on which radio station you listen to, since some stations will be stronger than others. You don't need to talk into the speaker to jam because your transmission itself does the jamming, not what you say. If the jammed radio station is weak enough then you may be able to talk into the speaker and be heard on the radio as if you had taken control of the radio station.

## EXPERIMENT #41: Blinking Lights

Take a look at the schematic. This circuit configuration is a type of oscillator called an astable multivibrator. What do you think it will do? Connect the wires according to the Wiring Checklist, noting that the transistor bases are not connected although their wires cross in the schematic. Initially set the variable resistor (VR) to its minimum value (turn it to the right). Press the switch and hold it down. One LED is on while the other is off, and they change about every second. What do you think will happen as you turn the knob on the VR? The right LED stays on longer than the left one.

In this circuit, one transistor is always on while the other is off. In this type of oscillator there is no inductor, the frequency is controlled only by the resistors and capacitors. The  $100\text{K}\Omega$  and  $10\mu\text{F}$  determine how long NPN1 is on and the  $3.3\text{K}\Omega$ , VR, and  $100\mu\text{F}$  determine how long NPN2 is on. If you want to experiment with changing part values, go ahead. But don't replace the capacitors with the smaller disc ones (you'll see why in the next experiment).

Blinking lights like this are often used to attract people's attention.

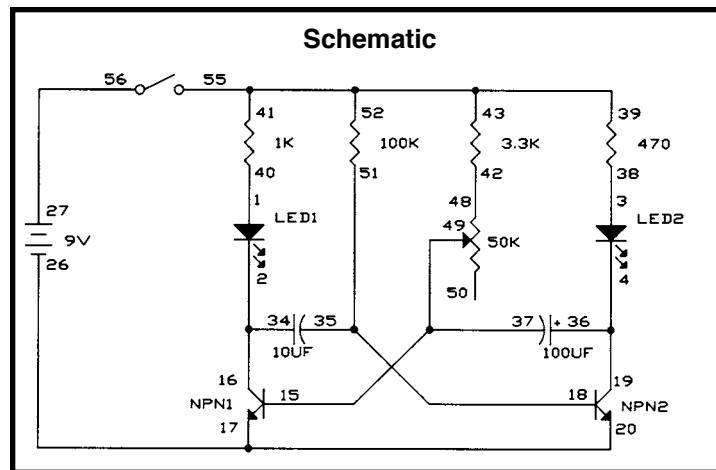

### Wiring Checklist:

- 27-to-56
- 55-to-52-to-43-to-41-to-39
- 40-to-1
- 2-to-16-to-34
- 35-to-51-to-18
- 38-to-3
- 4-to-19-to-36
- 15-to-37-to-49
- 48-to-42
- 17-to-20-to-26

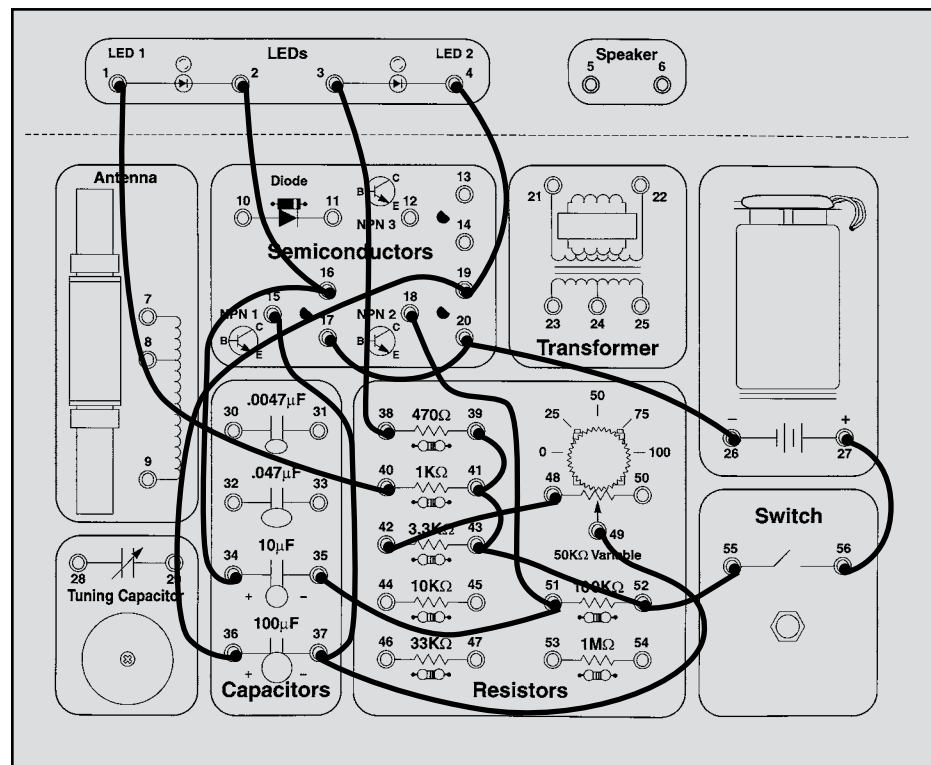

## EXPERIMENT #42: Noisy Blinker

This circuit is similar to the last one. Connect the wires according to the Wiring Checklist (noting that the transistor bases are not connected although their wires cross in the schematic). Press the switch and hold it down. The LED lights and you hear sound from the speaker. Turn the knob on the variable resistor and the frequency of the sound changes. Can you tell what the LED is really doing? It is actually blinking about 500 times a second, but to your eyes it appears as a blur or just dim. (This is why we told you not to replace the large capacitors with small ones like these in the last experiment).

You can experiment with changing component values if you like. The  $470\Omega$  resistor limits the sound loudness, replace it with a wire to make the sound louder and replace it with a  $10K\Omega$  to make the sound softer. Swapping the two capacitors in the circuit will make the sound frequency higher, replacing them with the  $10\mu F$  or  $100\mu F$  will make the frequency much lower. You can also change some of the other resistors.

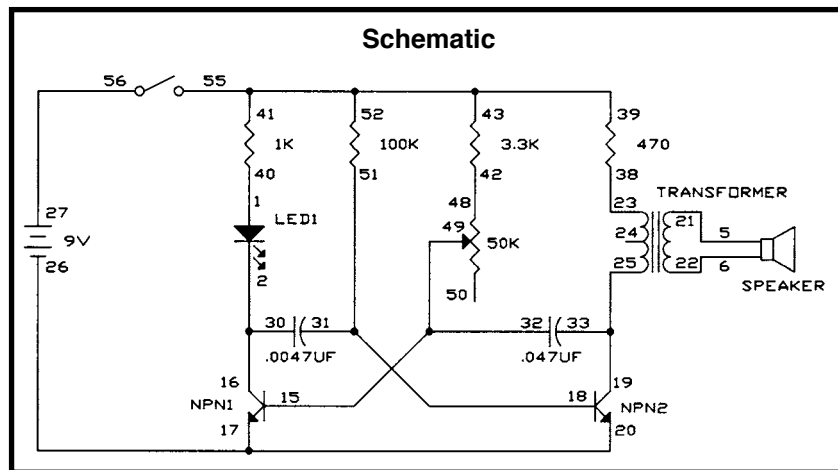

### Wiring Checklist:

- 27-to-56
- 55-to-52-to-43-to-41-to-39
- 40-to-1
- 2-to-16-to-30
- 18-to-31-to-51
- 38-to-23
- 25-to-19-to-32
- 15-to-33-to-49
- 48-to-42
- 17-to-20-to-26
- 5-to-21
- 6-to-22

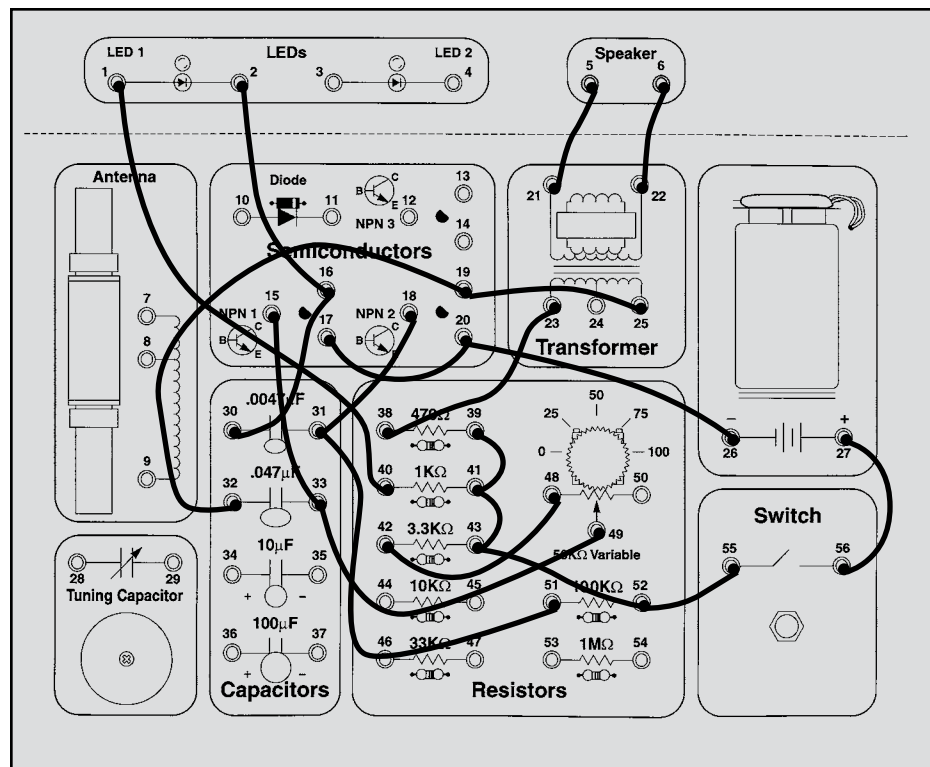

## EXPERIMENT #43: One-shot

Do you know what this circuit will do? Connect the wires according to the Wiring Checklist (noting that the transistor bases are not connected although their wires cross in the schematic). Press the switch and release it. The LED is on for a few seconds and then goes out. What effect do you think changing the value of the variable resistor will have? Try it. The higher the resistance the longer the LED stays on.

This circuit is a variation of the astable multivibrator and is called a one-shot multivibrator, because the LED comes on once each time the switch is pressed. The 33K $\Omega$ , variable resistor, and 100 $\mu$ F control how long the LED is on. This circuit can be used as a timer. You might use a circuit like this with your microwave oven. You press the switch to turn the oven on and have a knob (the variable resistor) to adjust how long the oven stays on; it then shuts off automatically.

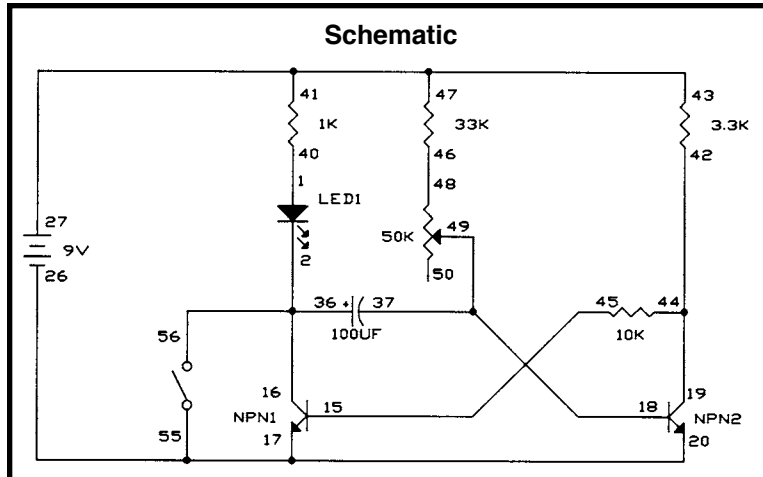

### Wiring Checklist:

- 40-to-1
- 2-to-16-to-36-to-56
- 17-to-20-to-26-to-55
- 37-to-49-to-18
- 46-to-48
- 44-to-42-to-19
- 15-to-45
- 41-to-43-to-47-to-27

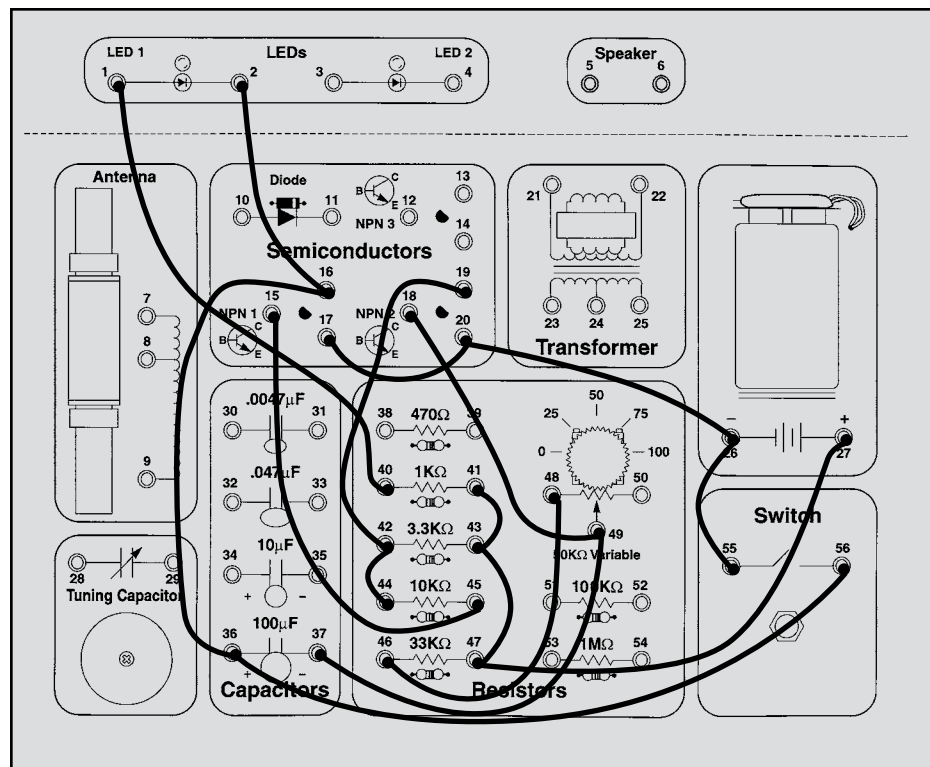

# EXPERIMENT #44: Alarm with Shut-off Timer

Let's demonstrate a use for the timer circuit you just built by combining it with Experiment 28, the Alarm. Connect the wires according to the Wiring Checklist (noting that the transistor bases and transformer springs 23 and 24 are not connected although their wires cross in the schematic). Connect the alarm trip wire and then connect the battery wire to turn the circuit on. Press the switch once. Now disconnect the trip wire to activate the alarm.

The alarm stays on for a few seconds and then goes off. Reconnect the trip wire and press the switch to reset the alarm and timer. If you only re-connect the trip wire without resetting the timer then the alarm won't work the next time. You could use a circuit like this where you get lots of false alarms and you want to shut off the alarm before the battery gets weak. Automobile alarms, for example, get lots of false alarms.

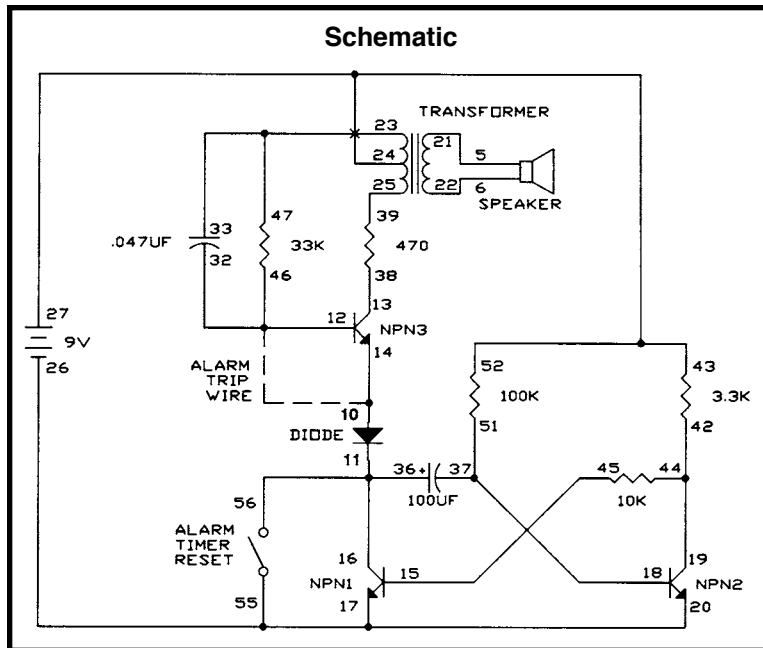

### Wiring Checklist:

- 11-to-16-to-36-to-56
- 10-to-14
- 17-to-20-to-26-to-55
- 37-to-51-to-18
- 44-to-42-to-19
- 15-to-45
- 5-to-21
- 6-to-22
- 23-to-33-to-47
- 12-to-32-to-46
- 13-to-38
- 39-to-25
- 12-to-14 (use a long wire, this will be referred to as the "trip" wire)
- 43-to-52-to-27-to-24

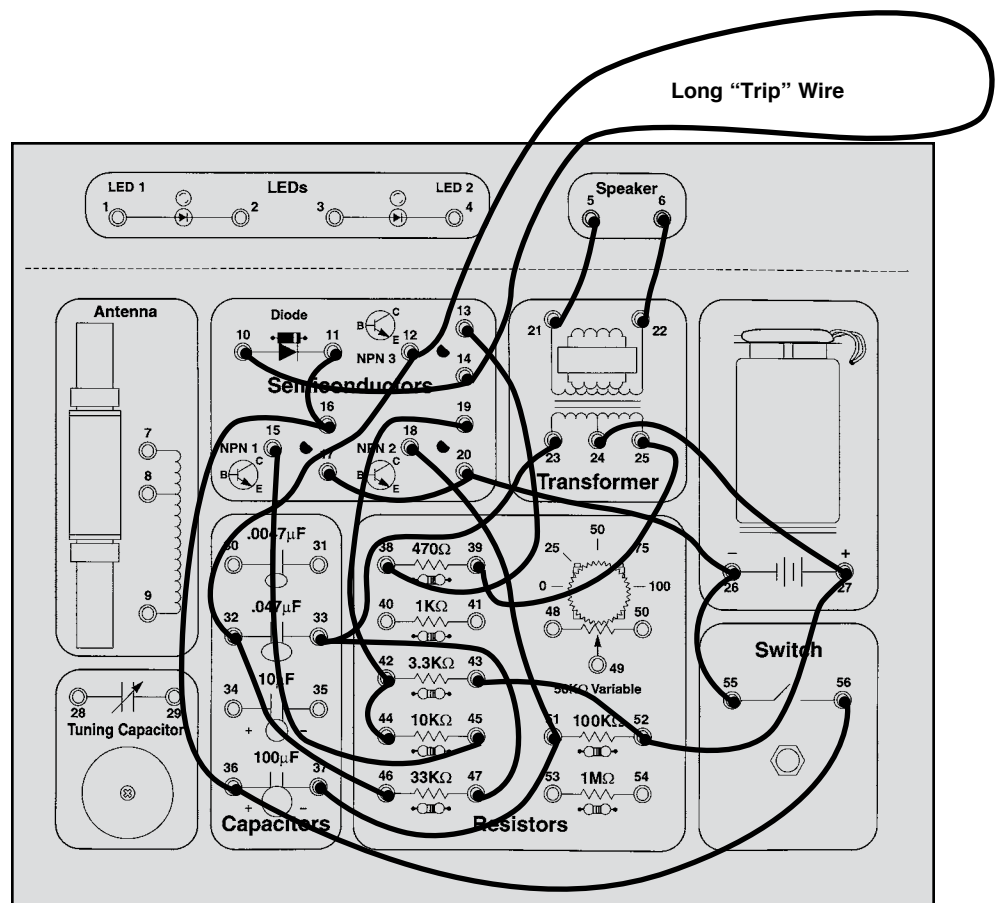

# EXPERIMENT #45: The Flip-Flop

This circuit is yet another variation of the basic multivibrator configuration. Connect the wires according to the Wiring Checklist. One LED will be on, the other off. Take the loose wire and touch it to the base of the transistor that is on (spring 15 or 18). That transistor turns off and the other turns on. Do this a few more times until you see that touching the “on” transistor base “flips” the transistors and the LEDs. You might say that the transistor turning on “flips” and the one turning off “flops”. Notice that touching the “off” transistor base has no effect.

This circuit is called formally known as the bistable switch, but is nicknamed the “flip-flop” due to the way it operates. The name flip-flop may seem silly to you at first, but variations of this circuit form one of the basic building blocks for digital computers. This circuit can be thought of as a memory because it only changes states when you tell it to, it “remembers” what you told it to do even though you removed the loose wire. By combining several of these circuits you can remember a letter or number. By combining thousands of these circuits a computer can remember a small book. A typical computer has many thousands of flip-flops, all in integrated circuit form. The operation of this circuit is simple. If NPN1 is on then

it will have a low collector voltage. Since this collector voltage also connects to NPN2’s base, NPN2 will be off. But if you ground NPN1’s base then it will turn off and its collector voltage rises, turning on NPN2. NPN2 will stay on until you ground its base.

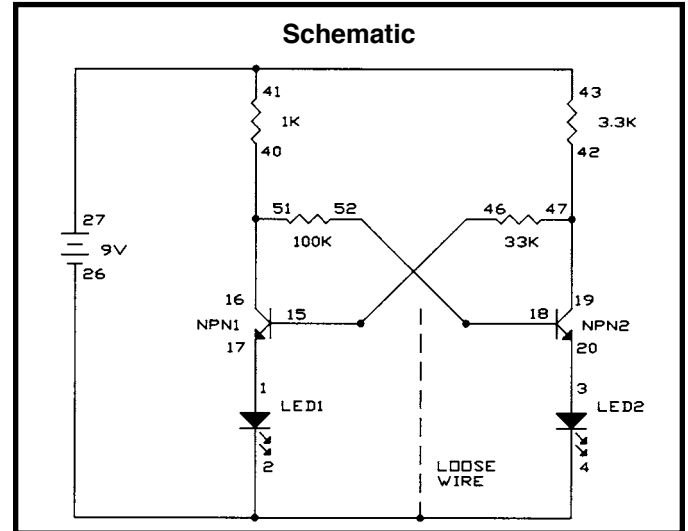

### Wiring Checklist:

- 16-to-40-to-51
- 52-to-18
- 19-to-42-to-47
- 46-to-15
- 17-to-1
- 20-to-3
- 2-to-4-to-26-to-unconnected
- 41-to-43-to-27

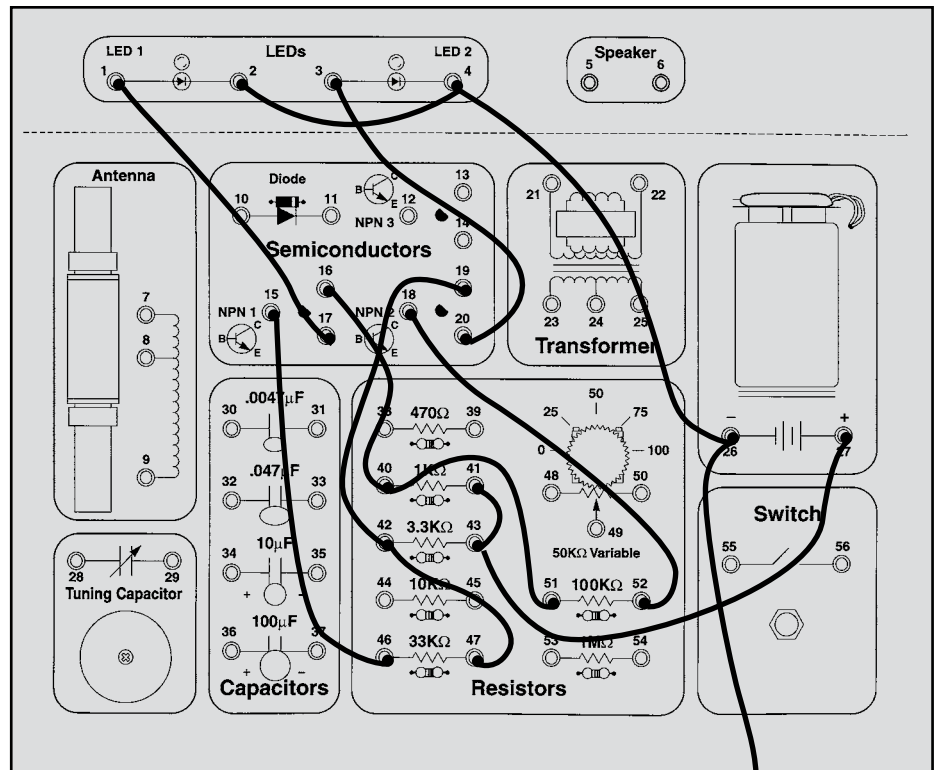

Loose Wire



## EXPERIMENT #46: Finger Touch Lamp with Memory

Instead of using the wire to flip-flop the LED you may also use your fingers as you did in Experiment 19, the Finger Touch Lamp. We'll use almost the same circuit here as in the last experiment. Just replace LED2 with the diode (move the wire on spring 3 to spring 10, and the wires on spring 4 to spring 11) because we don't need two "lamps". Wet two fingers and hold one on battery spring 27 while touching the other to the transistor base springs. But now you must touch the base of the "off" transistor to make them flip-flop, not the "on" base. Do you know why? Your body has more resistance than the other resistors in

the circuit and cannot "short circuit" the transistor bases to circuit ground like the wire can. So instead we connect the off transistor to the battery to turn it on.

But this uses two fingers and in Experiment 19 we also had a one-finger version, so can we do that here? Connect wires between springs 41 and 32, between 15 and 30, and between 18 and 34. Wet a large area of one of your fingers and touch it to springs 30 and 32 or 32 and 34 at the same time. Now we have a one-finger touch lamp with memory!

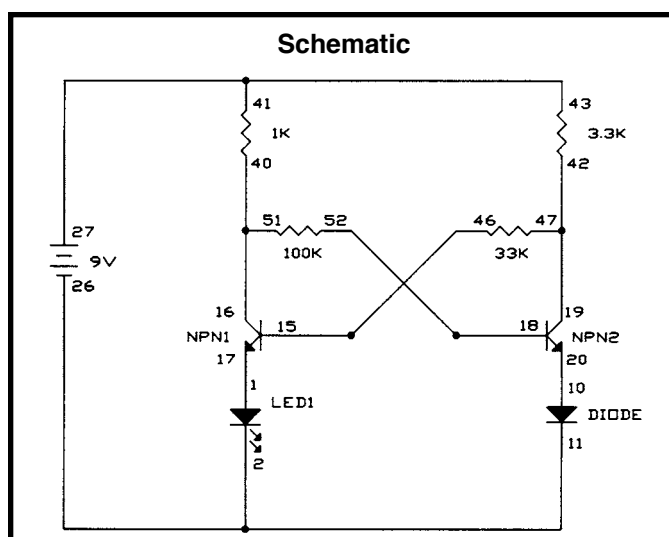

# EXPERIMENT #47: This OR That

Now that you're familiar with the flip-flop, let's introduce some more digital circuits. Digital circuits are circuits that have only two states, such as high-voltage/low-voltage, on/off, yes/no, and true/false. Connect the wires according to Wiring Checklist. Take a look at the schematic, it is very simple. Wires X and Y are considered to be digital inputs, so connect them to either the battery spring 27 (9V, or HIGH) or leave them unconnected (this is the same as connecting them to 0V, or LOW). Test the four combinations of X and Y to determine the state of LED1 (ON or OFF), filling in the table below:

X	Y	LED 1
LOW/UNCONNECTED	LOW/UNCONNECTED	
LOW/UNCONNECTED	HIGH/POWER	
HIGH/POWER	LOW/UNCONNECTED	
HIGH/POWER	HIGH/POWER	

This type of table is called a **truth table**. From it, you can see that if X *or* Y is HIGH then LED1 will be ON. Hence, this configuration is called an **OR gate**. X and Y might represent two switches to turn on a light in your house. Or they might represent sensors at a railroad crossing; if either senses a train coming they start the ding-ding sound and lower the gate. You could also have more than two inputs, by adding more parts to your circuit and more columns to the truth table.

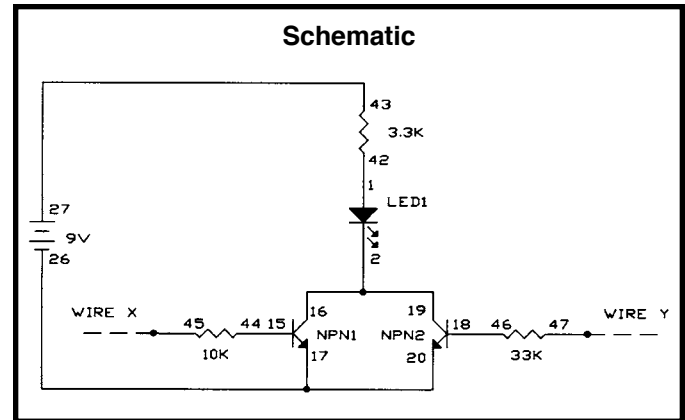

### Wiring Checklist:

- 17-to-20-to-26
- 42-to-1
- 2-to-16-to-19
- 15-to-44
- 45-to-unconnected  
(this is referred to as wire X)
- 18-to-46
- 47-to-unconnected  
(this is referred to as wire Y)
- 43-to-27

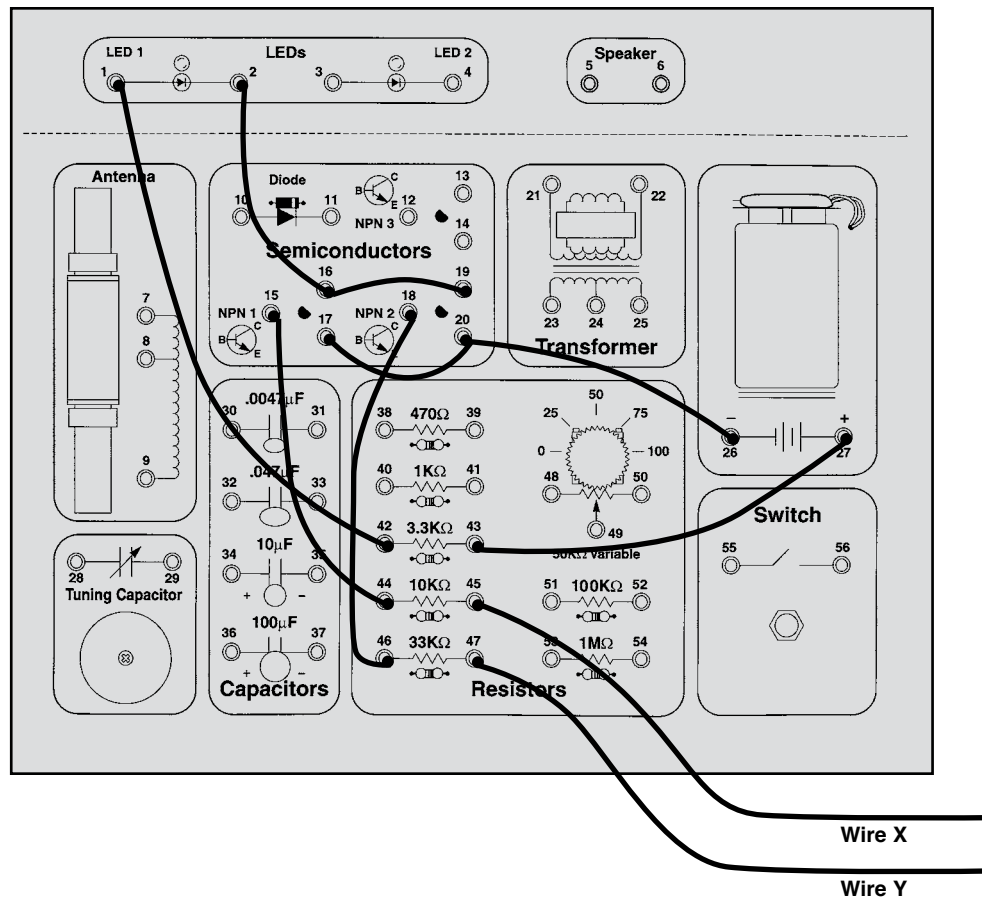

# EXPERIMENT #48: Neither This NOR That

Now let's add on to the previous circuit by adding the wires listed in the Wiring Checklist (these are in addition to the wires from Experiment 47, which you should still have assembled). Test the four combinations of X and Y as before to determine the state of LED2 (ON or OFF), filling in the table at right:

X	Y	LED 2
LOW	LOW	
LOW	HIGH	
HIGH	LOW	
HIGH	HIGH	

This table shows that if neither X *nor* Y is HIGH then LED2 is ON. Hence, this configuration is called a **NOR gate**. X and Y might represent your burglar alarm and flood detector, so if neither X nor Y is on then your "all clear" light goes on. You may also think of this as adding a NOT gate to an

OR gate to produce a NOR gate. A **NOT gate** is just the opposite of its input:

Input	NOT
LOW	HIGH
HIGH	LOW

Gates such as OR, NOR, and NOT form some of the basic building blocks for computers. The combinations of resistors and transistors shown here to build them are a form of Resistor-Transistor-Logic, which was used extensively in early generations of computers and which led to the development of many of today's logic families. These basic gates are so commonly used that they have their own symbols:

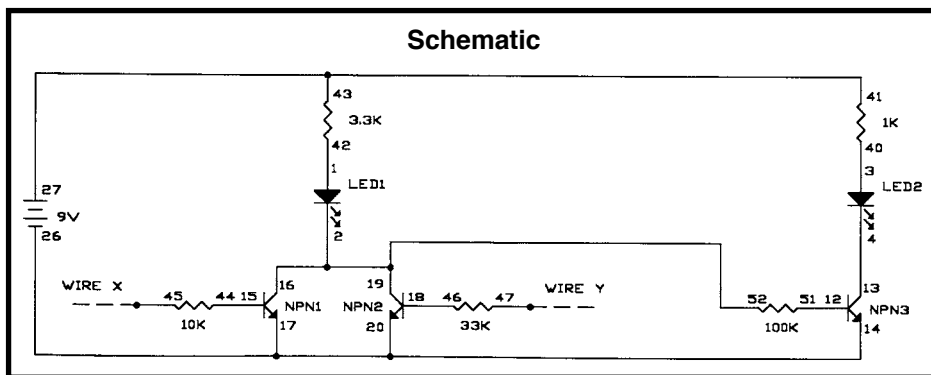
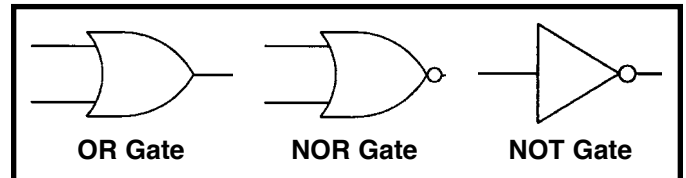

Wiring Checklist (additions to Experiment 47 Checklist):

- 14-to-26
- 40-to-3
- 4-to-13
- 12-to-51
- 41-to-43
- 19-to-52

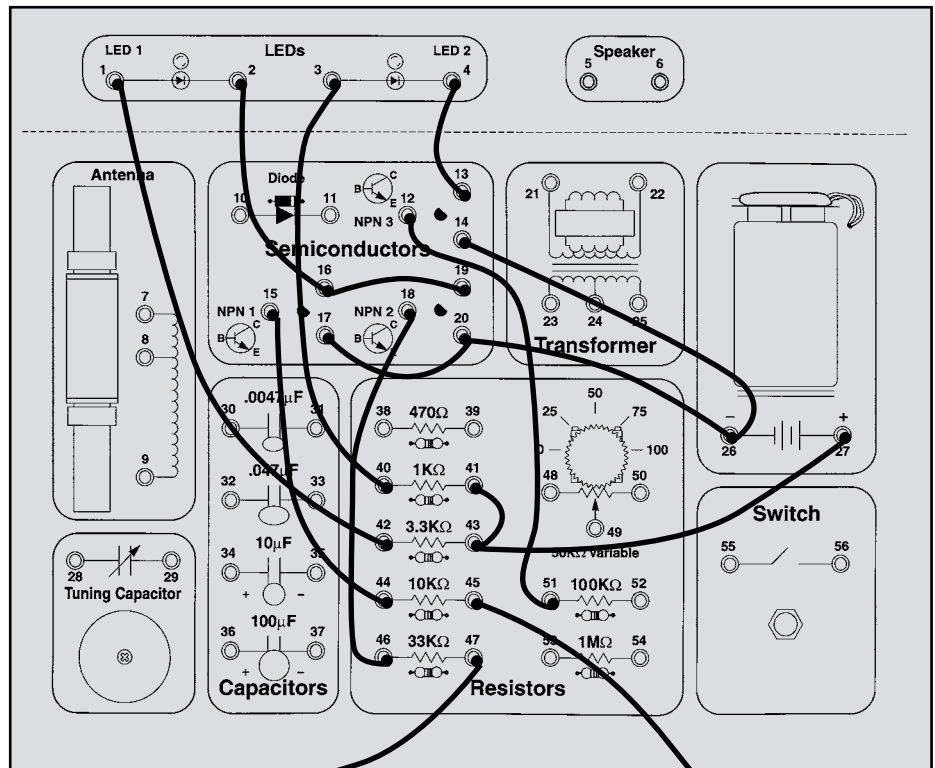

Wire Y

Wire X

## EXPERIMENT #49: This AND That

Take a look at the schematic. Can you guess what kind of digital gate this is? We'll use almost the same circuit here as in the last experiment. Remove the wire between springs 17 and 20, and the one between springs 16 and 19. Add a wire between springs 17 and 19. Also, disconnect the 100KΩ by removing the wire between springs 19 and 52, we'll re-connect it later.

Test the four combinations of X and Y to determine the truth table:

X	Y	LED 1
LOW	LOW	
LOW	HIGH	
HIGH	LOW	
HIGH	HIGH	

From it, you can see that if X and Y are HIGH then LED1 will be ON. Hence, this configuration is called an **AND gate**. X and Y might represent two switches to turn on the same light in your house, the room switch and the master switch in the electrical box. As with the gates we showed you earlier, you could have more than two inputs by just adding more parts to the circuit.

Now place the 100KΩ back into the circuit by connecting a wire between springs 17 and 52 (not 19 and 52), and look at LED2. Since you are just adding a NOT gate as you did in the last experiment you probably know what the new truth table will look like:

X	Y	LED 2
LOW	LOW	
LOW	HIGH	
HIGH	LOW	
HIGH	HIGH	

It is a **NAND gate**, a combination of AND and NOT. X and Y might represent different trip wires for your burglar alarm (if either is tripped then that input goes LOW and the alarm sounds). AND and NAND have the schematic symbols shown below:

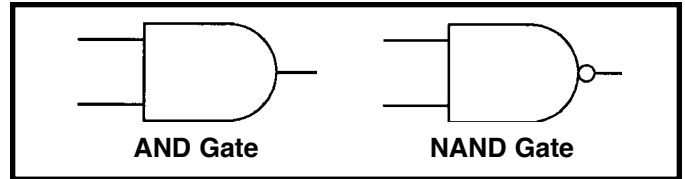

Combinations of AND and OR gates are used to add and multiply numbers together in computers. The additional use of NOT, NOR, and NAND gates allows a computer to represent any input/output pattern you can think of. By combining these gates with the memory and timing control that flip-flops provide, today's computers are created.

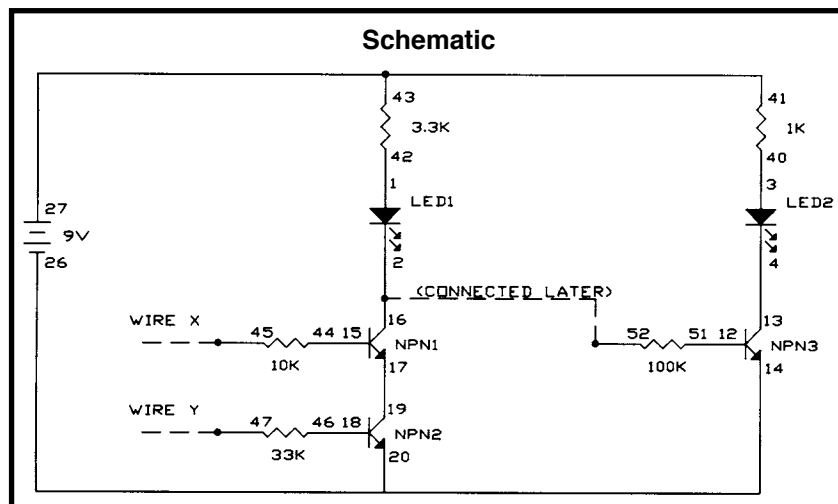

# EXPERIMENT #50: Audio AND, NAND

Using the LEDs for these truth tables probably seems a little boring. So let's use an audio circuit to make a sound instead of turning on the LED. Connect the wires according to the Wiring Checklist. Can you tell which digital gate this circuit represents? Construct the truth table to find out.

It is the NAND gate. If you use longer wires for X and Y and leave them connected HIGH then you have an alarm with two separate trip wires.

You can easily modify the circuit to be an AND gate. Remove the 3.3KΩ resistor and 10μF capacitor, connect spring 24 (transformer) to spring 27 (battery) instead of spring 16 (NPN1 collector), and connect spring 14 (NPN3 emitter) to spring 16 (NPN1 collector) instead of spring 20 (NPN2 emitter). This audio circuit can also be used with the OR and NOR gates simply by rewiring NPN1, NPN2, and the 10KΩ, 33KΩ resistors.

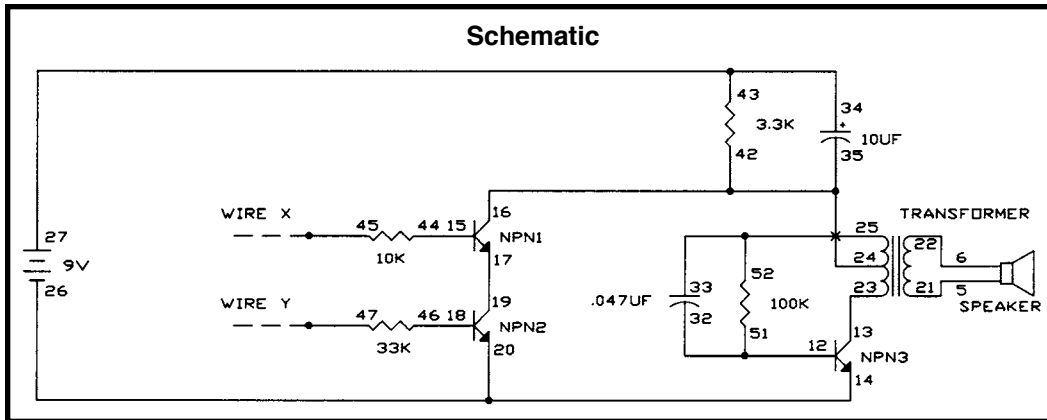

### Wiring Checklist:

- 14-to-20-to-26
- 17-to-19
- 15-to-44
- 45-to-unconnected (this is referred to as wire X)
- 18-to-46
- 47-to-unconnected (this is referred to as wire Y)
- 12-to-32-to-51
- 5-to-21
- 6-to-22
- 13-to-23
- 33-to-52-to-25
- 24-to-16-to-42-to-35
- 34-to-43-to-27

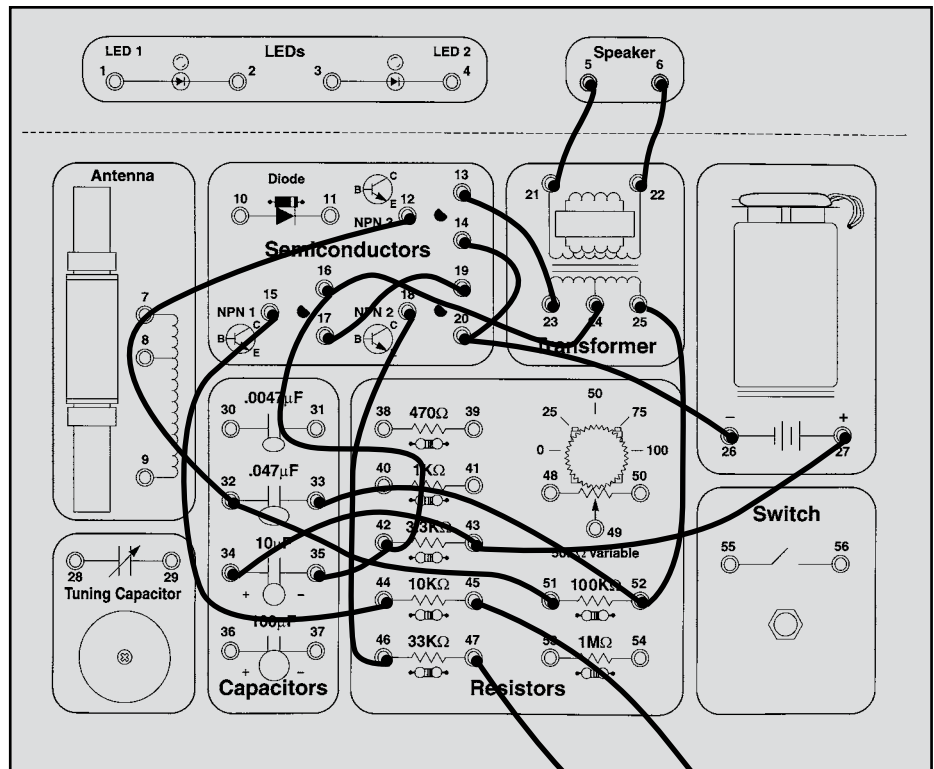

Wire X

Wire Y

# EXPERIMENT #51: Logic Combination

This last circuit is a combination of some of the other digital gates, and has 3 inputs. See if you can fill in the truth table by just looking at the schematic. Then connect the wires according to the Wiring Checklist, test all eight input combinations, and see if you were right.

What could this circuit be used for? It might be used to provide power for your telephones. Z would be controlled by the phone company and would be high if you paid your phone bill. X and Y could be different phones in your house and would be high when you pick up the phone. The transistor emitters would then provide voltage to the rest of the telephone circuit.

X	Y	Z	LED 1 Predicted	LED 1 Measured
LOW	LOW	LOW		
LOW	LOW	HIGH		
LOW	HIGH	LOW		
LOW	HIGH	HIGH		
HIGH	LOW	LOW		
HIGH	LOW	HIGH		
HIGH	HIGH	LOW		
HIGH	HIGH	HIGH		

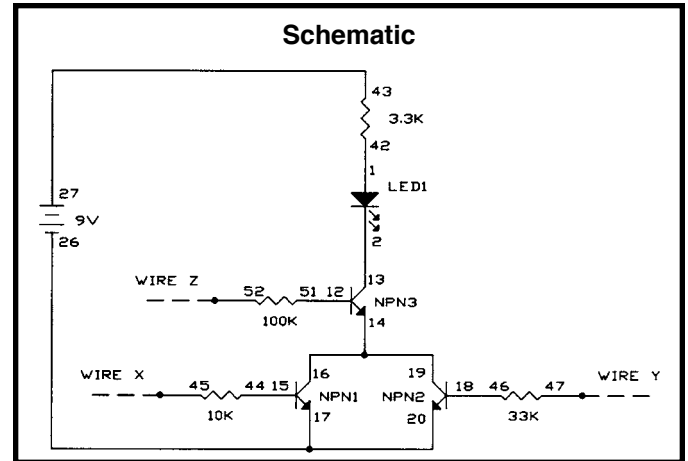

### Wiring Checklist:

- 17-to-20-to-26
- 16-to-19-to-14
- 13-to-2
- 1-to-42
- 15-to-44
- 45-to-unconnected (this is referred to as wire X)
- 18-to-46
- 47-to-unconnected (this is referred to as wire Y)
- 12-to-51
- 52-to-unconnected (this is referred to as wire Z)
- 43-to-27

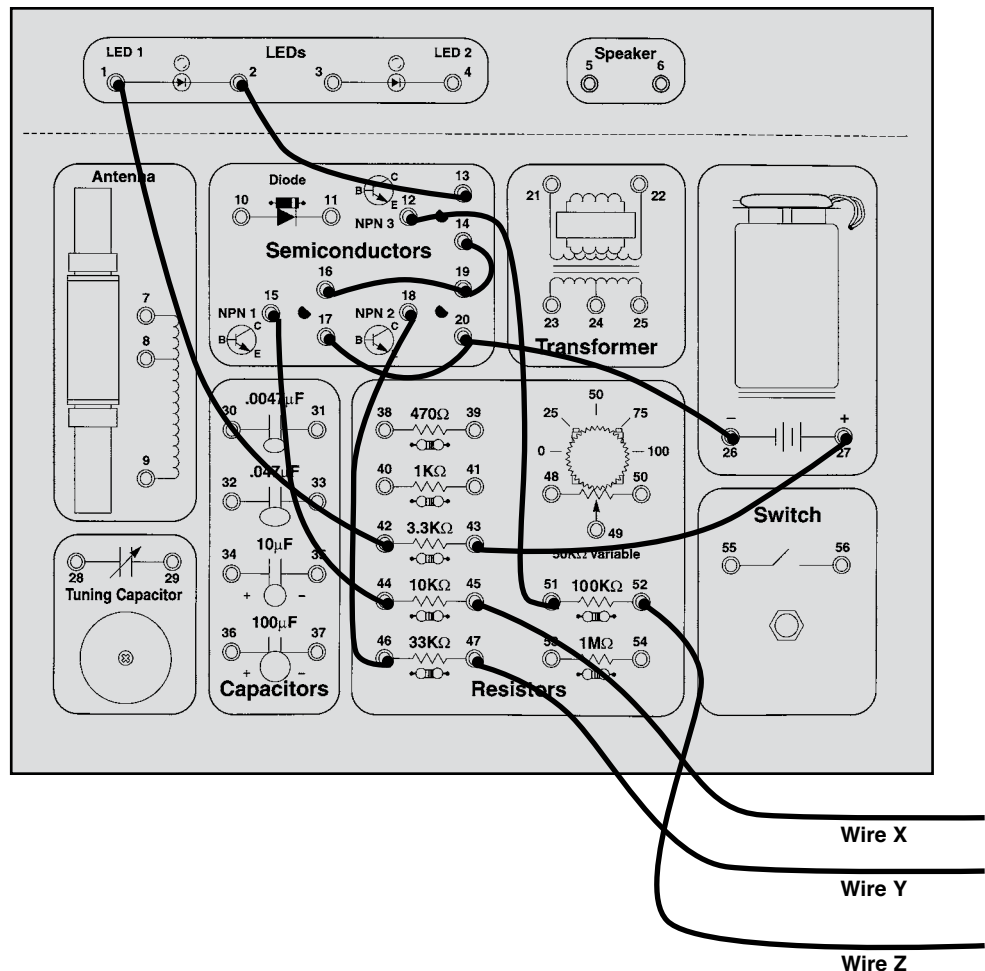

## EXPERIMENT #52: Auto-Off Night-Light

When you connect the battery the first time, the LED1 will come on and very slowly get dimmer and dimmer. This circuit would make a good night-light. It would allow you to get into bed, and then it would go out. No further current is taken from the battery so it will not drain the batteries even if left on all night.

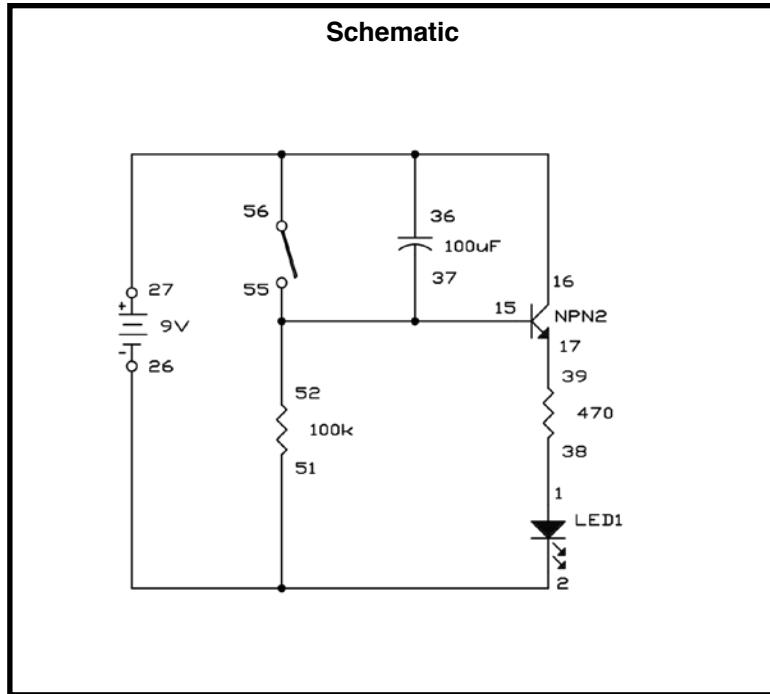

### Wiring Checklist:

- 16-to-36-to-56-to-27
- 2-to-51-to-26
- 15-to-37-to-52-to-55
- 17-to-39
- 38-to-1

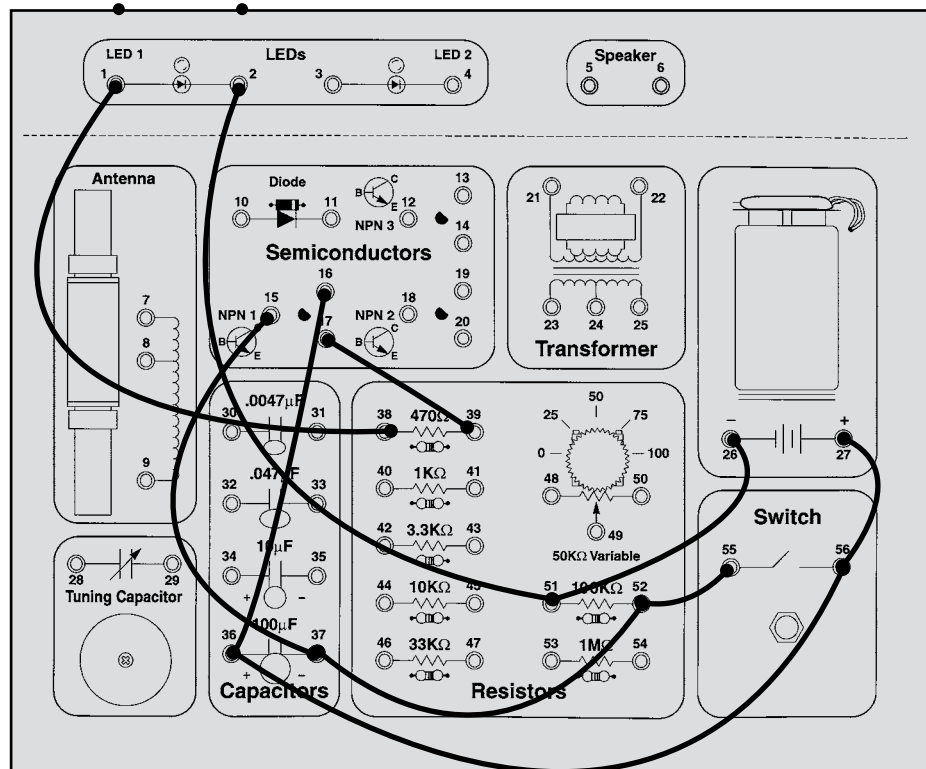

## EXPERIMENT #53: Storing Electricity

Connect the battery and the wire on spring 36 to spring 2. The LED1 will flash and the 100 $\mu$ F capacitor will be charged with electricity. Electricity is now stored in the capacitor. Disconnect the wire from spring 2 and connect it to 39 and the LED2 will flash for a short time.

The 100 $\mu$ F capacitor discharges through the resistor to the base of the NPN1 transistor. The current turns on the transistor like a switch, connecting to LED2 to the negative (-) side of the battery. LED1 will go out after the 100 $\mu$ F capacitor discharges because there is no more current at the base of the transistor.

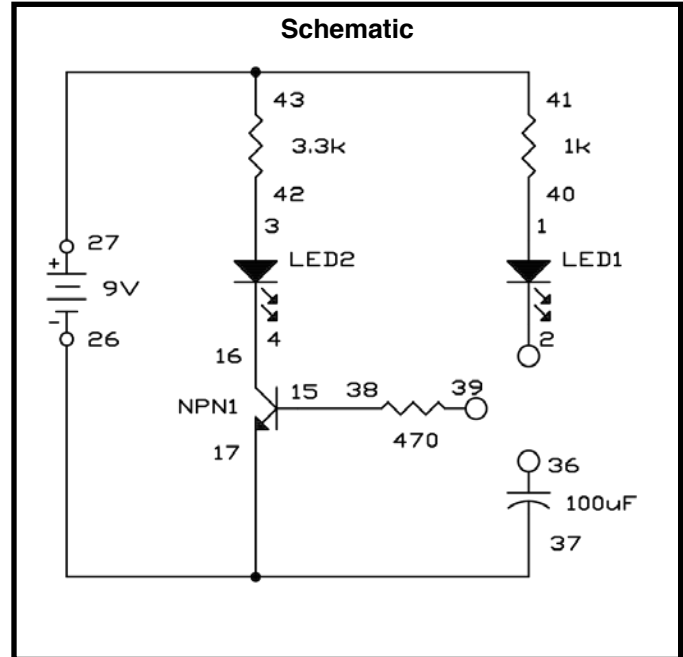

### Wiring Checklist:

- 27-to-41-to-43
- 40-to-1
- 36-to-wire
- 42-to-3
- 4-to-16
- 15-to-38
- 26-to-37-to-17

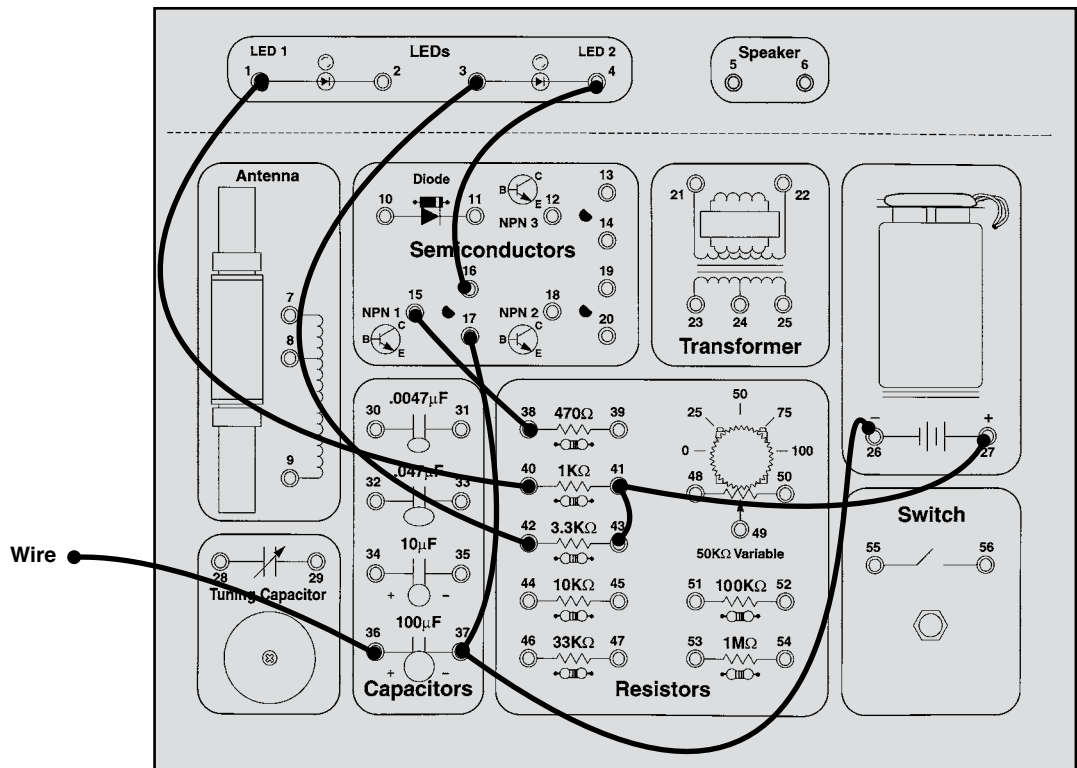



## EXPERIMENT #54: Strobe Light

In this experiment, you will be creating an oscillator circuit that doesn't make sound using a speaker. Instead the circuit will produce light with an LED. This will give you an idea of how larger strobe lights work. When you press the switch, watch the LED2 flash at a steady rate. Adjust the blink rate using the 50K $\Omega$  resistor. You may need to

press the switch several times before it starts blinking, and it may not be blinking if the 50K $\Omega$  resistor is set the to the right.

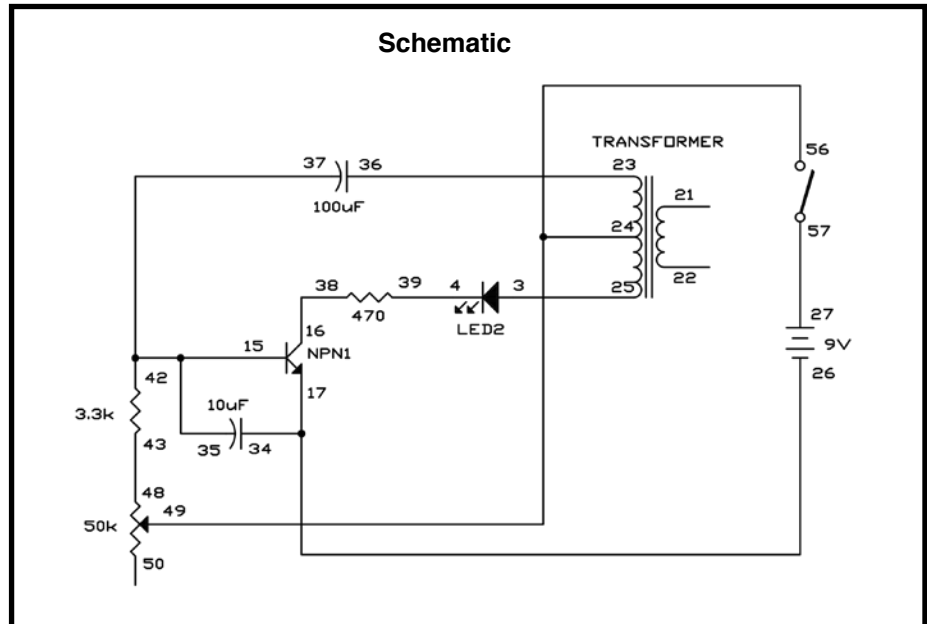

### Wiring Checklist:

- 23-to-36
- 24-to-56-to-49
- 25-to-3
- 48-to-43
- 16-to-38
- 4-to-39
- 15-to-42-to-35-to-37
- 26-to-17-to-34
- 27-to-55

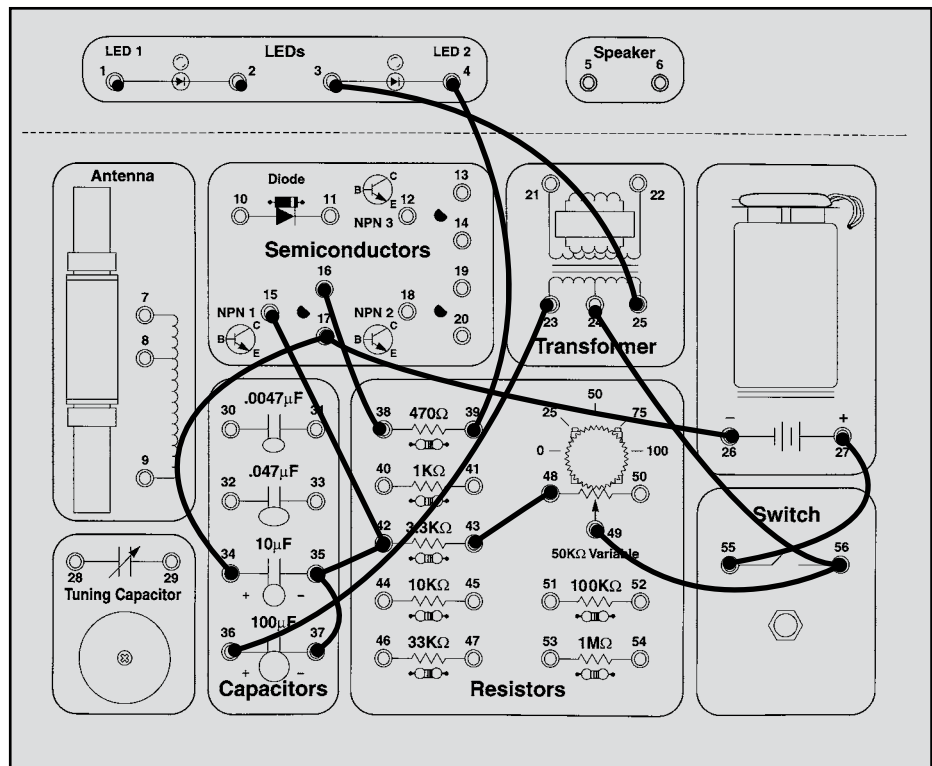

# EXPERIMENT #55: Grandfather Clock

Does your home lack a grandfather clock? With this experiment, you will make your own electronic grandfather clock.

This circuit will produce clicks at approximately one-second intervals. The sound and timing together might remind you of an old grandfather clock. If you would like for it to go faster or slower, then change out the 100KΩ resistor with another resistor.

The steady ticking can put animals (and people) into a sleepy state of mind. If you have ever traveled on a train, you remember how sleepy you get from hearing the clicking sound of the wheels.

Ever scare a clock out of ticking? Shout directly into the speaker. You can briefly stop the clock! The speaker acts like a microphone as well. The sound of your voice vibrates the speaker and disturbs the electrical balance of the circuit, briefly.

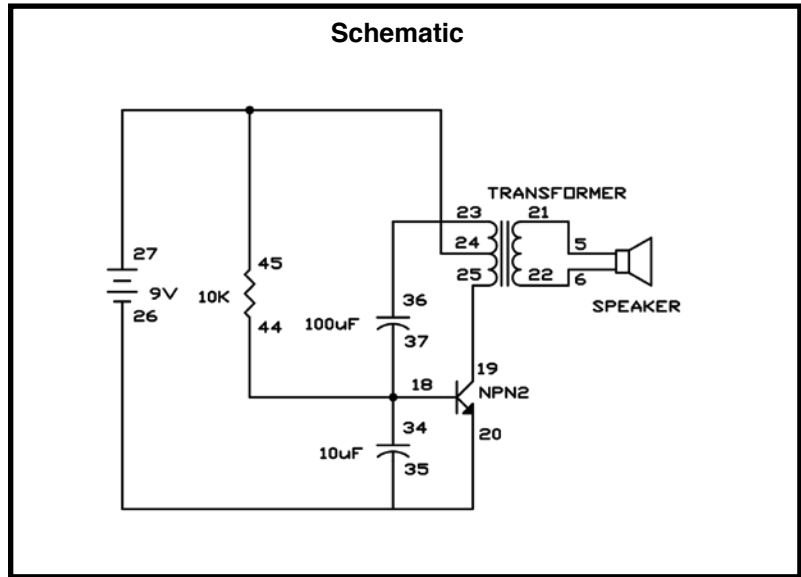

### Wiring Checklist:

- 27-to-52-to-24
- 19-to-25
- 5-to-21
- 6-to-22
- 23-to-36
- 18-to-34-to-37-to-51
- 26-to-20-to-35

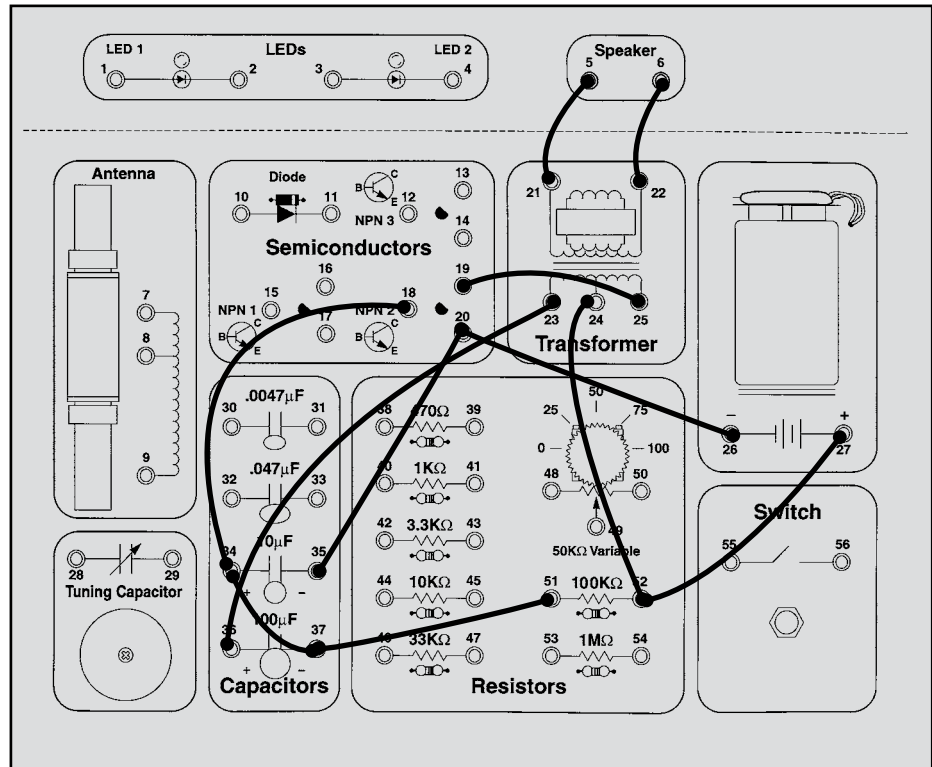

## EXPERIMENT #56: Time delay of 3 sec to 30 min

This circuit is based on learning the discharge and charge of the capacitor. This circuit can be used as a timer circuit and can be applied to turn On/Off electrical appliances. The application can also use a relay instead of an LED.

When you connect the battery, the LED1 lights, indicating a ready state.

Press down the switch (timer), current flows to .047 $\mu$ F capacitor until it is fully charged. When you release the switch, the capacitor discharges out through the 100K $\Omega$  resistor to the base of transistor NPN1.

Both NPN1 and NPN2 work together (Darlington mode) to increase the current to light up the LED2. The LED2 lights until the capacitor's voltage is too low to keep the transistor on. If you want the timer circuit longer, increase the value of the capacitor or increase the 10K $\Omega$  resistor. Disconnect the wire from spring 27 turn off the circuit.

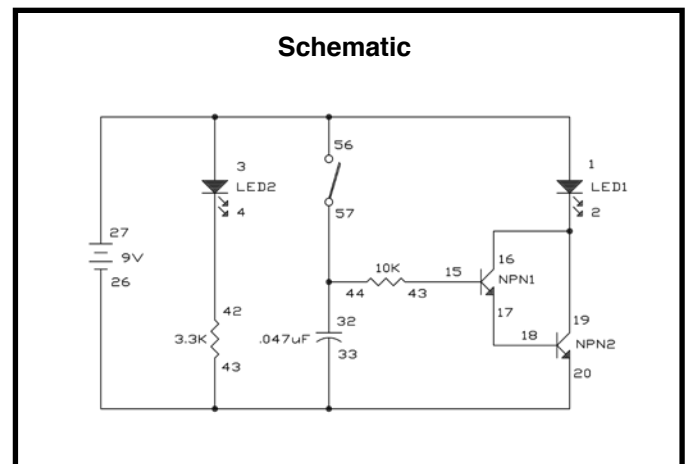

### Wiring Checklist:

- 27-56-41-3
- 40-1
- 26-to-43-to-33-to-20
- 2-to-16-to-19
- 17-to-18
- 15-to-44
- 32-to-45-to-55
- 4-to-42

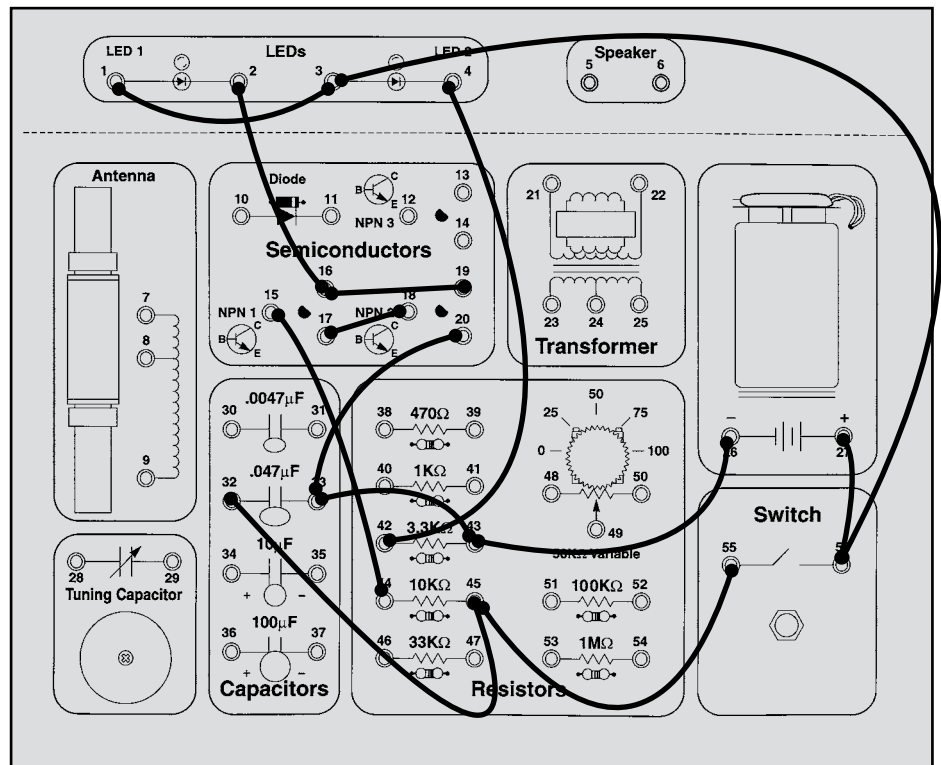

# EXPERIMENT #57: The Slow Motion Sunrise/Sunset Light

In the circuit, the light from the LED comes on extremely slow. Complete the wiring and hold the LONG WIRE to spring 54. In about twenty seconds, the LED will begin to light up. Remove the LONG WIRE and the LEDs will slowly go off. The LEDs will go off quickly if you touch the LONG WIRE to 37.

The LEDs comes on more slowly because of the increase resistance in the input, and because both transistors must be switched on before the LEDs (connected to the output) can light up. Change the 100µF to a smaller value make the LEDs turn on and off faster.

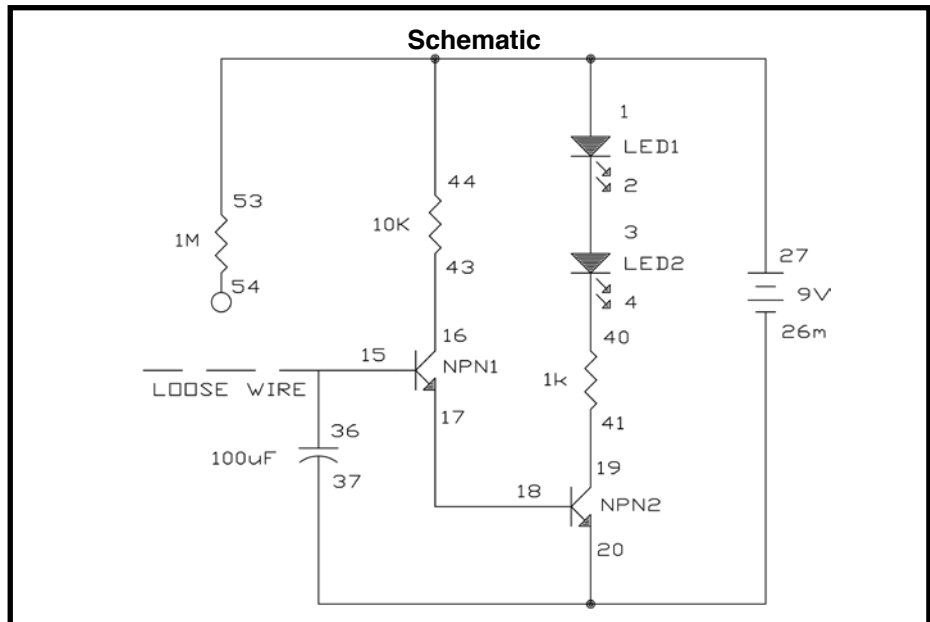

## Wiring Checklist:

- 27-to-1-to-44-to-53
- 26-to-20-to-37
- 2-to-3
- 4-to-40
- 19-to-41
- 16-to-45
- 15-to-36-to-unconnected (use long wire)
- 17-to-18

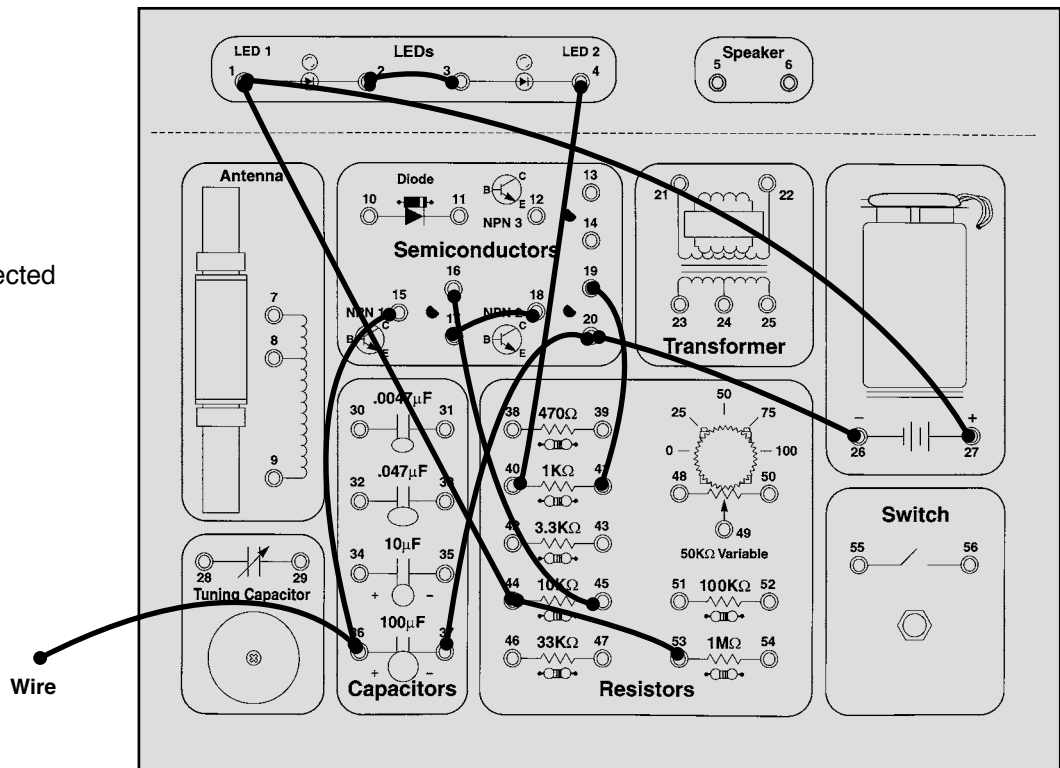

# EXPERIMENT #58: OHMmeter

An ohmmeter is a device that measures the resistance of a circuit or component. Most ohmmeters have a meter or LCD display to indicate the resistance. This project is a bit different in that it compares resistance between various parts.

The project is actually a version of the audio oscillator circuit we've used in other projects. When a resistance is connected across the two long wires, it provides negative feedback so the circuit can oscillator. Measure the

resistance of several different resistor in your kit. What differences in sound do you notice when you measure different value resistors? Is there a pattern to these changes? Lower resistance give a higher pitch sound.

Try touching the end of the two long wire together. What do you hear now from the speaker? Can you explain why this happens?

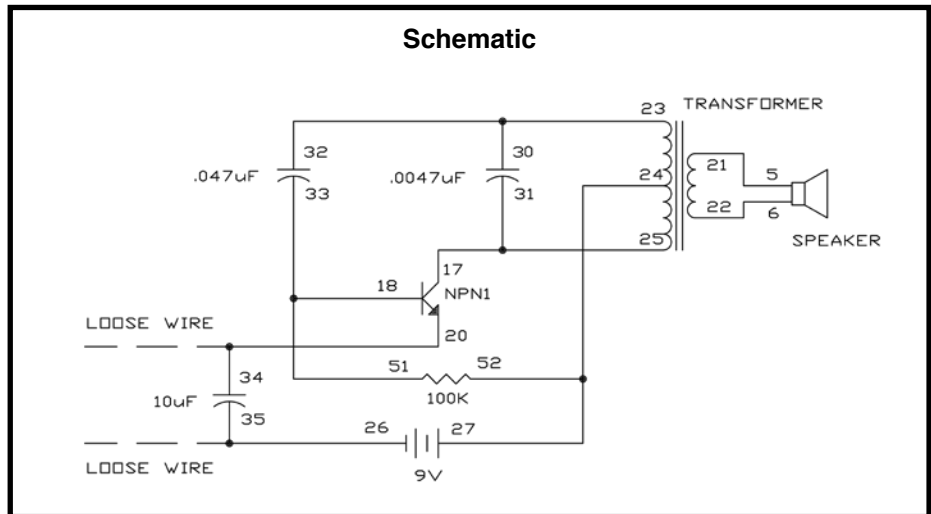

### Wiring Checklist:

- 23-to-30-to-32
- 25-to-19-to-31
- 18-to-33-to-51
- 24-to-27-to-52
- 26-to-35-to-unconnected (use long wire)
- 20-to-34-to-unconnected (use long wire)
- 21-to-5
- 22-to-6

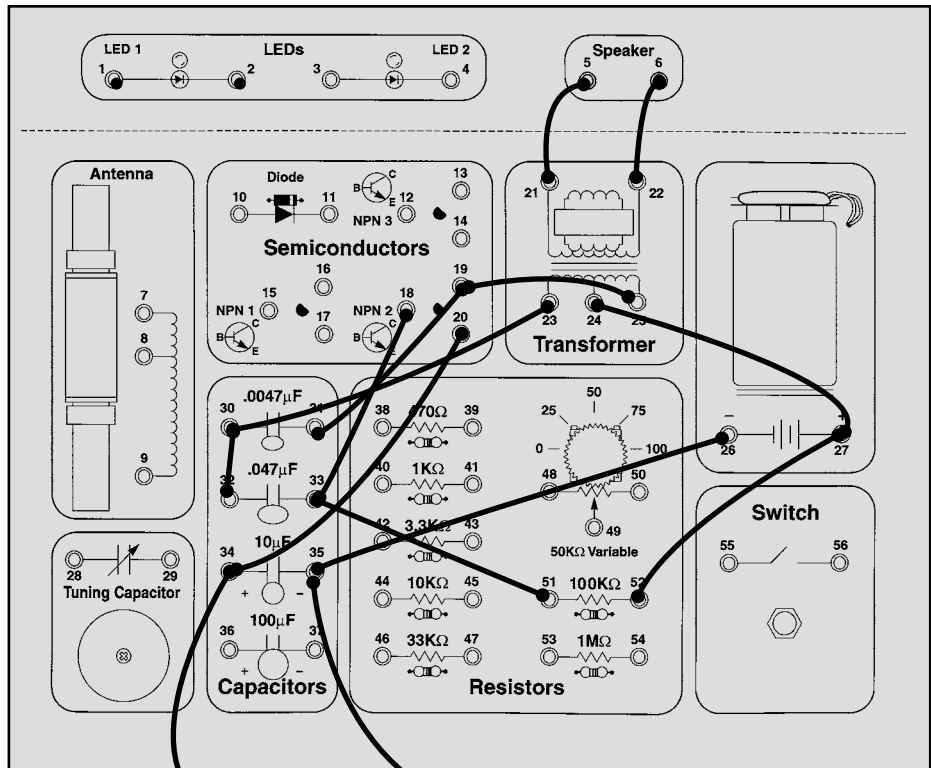

## EXPERIMENT #59: The Metal Detector

Perhaps you seen people at the beach or a park searching for buried treasure with their metal detectors, and you've wonder how an electronic devices can see the metal.

When the circuits is complete, you will need a AM radio to act as the voice of the circuit. Set the dial to the station that is weak and does not come in clearly. Then adjust the TURNING KNOB until the radio station is blocked out by the "squeal". Next fine-tune the TUNING KNOB until you get the lowest tone "squeal" you can. Now you 're ready to test.

Take a piece of metal and touch it to the end of the ANTENNA COIL core. The squeal tone will go away to indicate the presence of metal.

This circuit is a radio wave transmitter similar to the others you built, but in this circuit the signal from the transmitter is used to interfere with or block out another weak signal. When metal is touched to the core of the ANTENNA COIL the frequency of the blocking signal is changed enough to stop its interference with the weak radio station, and that is your signal that metal is present.

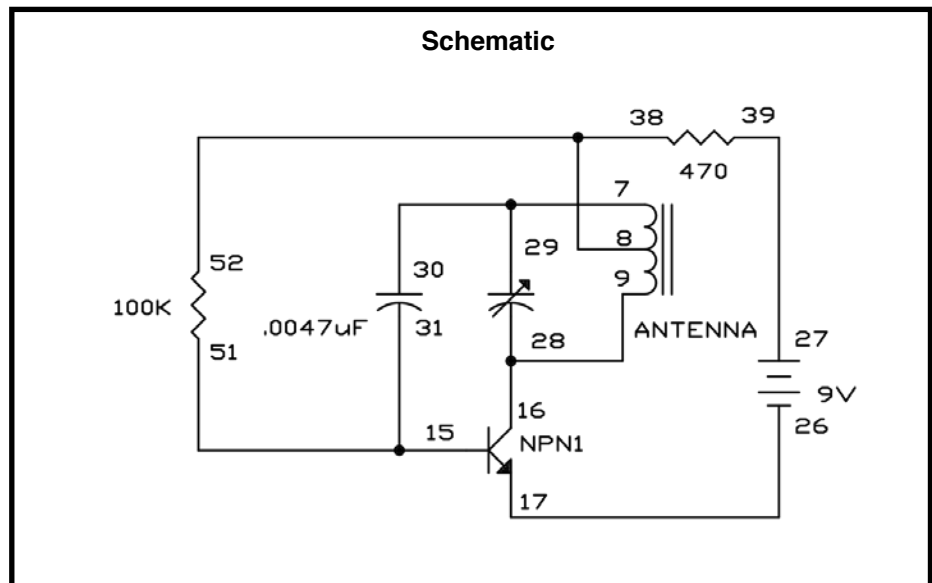

Wiring Checklist:

- 27-to-39
- 26-to-17
- 16-to-9-to-29
- 7-to-30-to-29
- 15-to-31-51
- 8-to-38-52

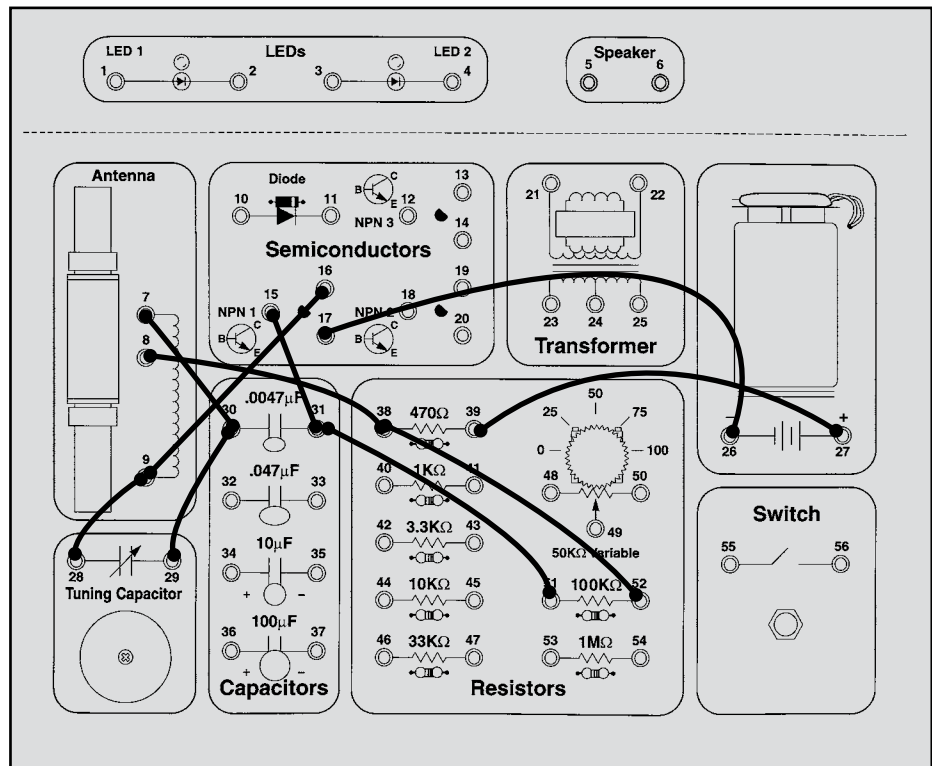

## EXPERIMENT #60: Inverter Circuit

Let's learn about an important family of circuits. These are called *logic circuits*. They let us control the output of the circuit from one or more inputs.

Connect the wires.

The logic circuit in this project is called an inverter because the circuit inverts, or turns upside down, the input signal. The LEDs in the project indicate the state of the input and outputs. LED1 indicates the input status and the LED2 for the output.

Connect the battery and only LED2 should light up. The input is LOW and the output HIGH. The switch controls the input of the circuit. When you press the switch down, you apply 9V (HIGH) to the input (spring 55), the LED1 turns on and the LED2 turns off.

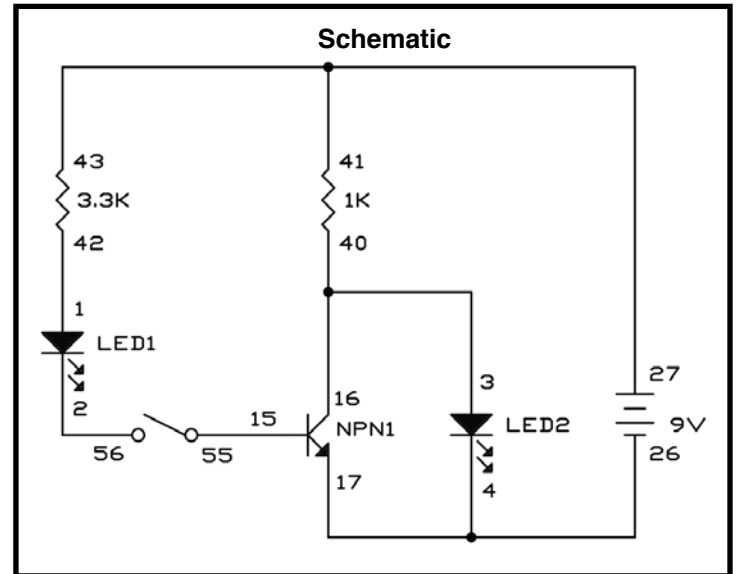

### Wiring Checklist:

- 27-to-41-to-43
- 26-to-17-to-4
- 40-to-16-to-3
- 1-to-42
- 2-to-56
- 15-to-55

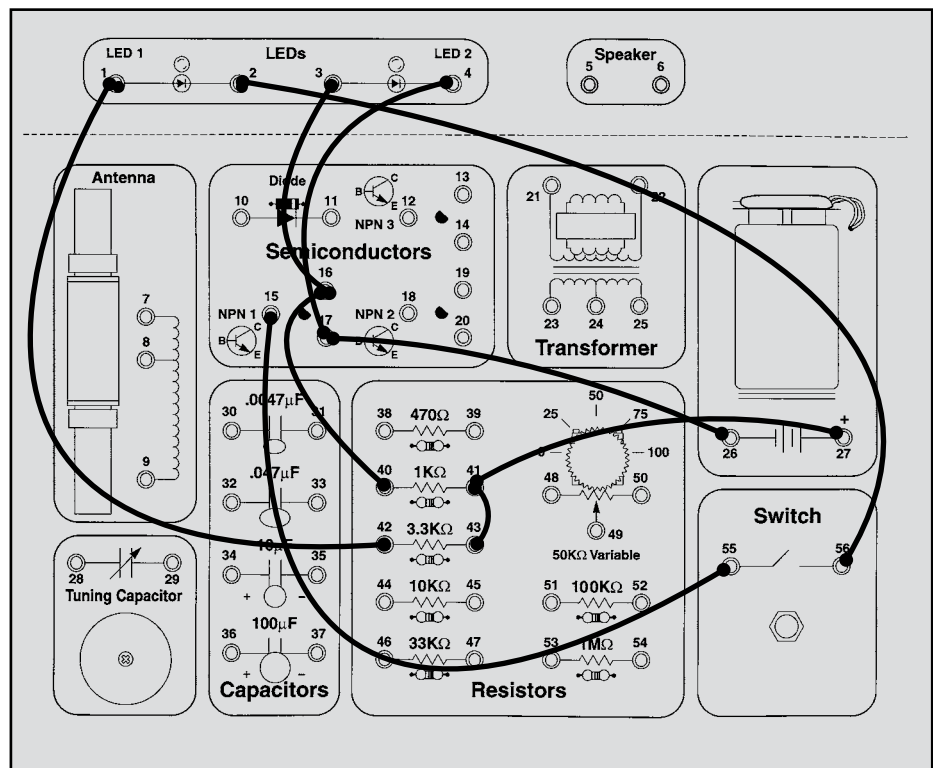

**Congratulations!** You've finished all the experiments and can now show your friends how much you know about electronics! What to do next? Well, you can re-do your favorite experiments or look our list of other ELENCO® learning products!

---

## TEST YOUR KNOWLEDGE #3

1. Adjusting the input to something based on what its output is doing is an example of \_\_\_\_\_.
2. A speaker converts electrical energy into \_\_\_\_\_ variations, called sound waves.
3. An oscillator's frequency \_\_\_\_\_ when you add resistance or capacitance.
4. Sending information through the air using electromagnetic waves is called \_\_\_\_\_.
5. Long wires start to act like \_\_\_\_\_ at high frequencies.
6. A NOR gate followed by a NOT gate is the same as an \_\_\_\_\_ gate.
7. An AND gate followed by a NOT gate is the same as a \_\_\_\_\_ gate.

(Answers are on page 5).

---

## TROUBLESHOOTING GUIDE

- Check your wiring against the Wiring Checklist and the schematic, very carefully. Be sure all your wires are securely in place and not loose. Also make sure the metal in the wires is only contacting the spring and wires that it is connected to, and not to any nearby springs or other wires. Nearly all problems are due to wiring errors. Also remember that the battery and electrolytic capacitors have "+" and "-" terminal markings.
- Be sure you have a good 9V battery. If not sure then try a new battery.
- Flip your Playground over and examine the connections on the back side. Every spring should have a wire from a component connected to it, and the connections should be secure (not loose). No wires should be touching any other wires on the back side (exception: two wires from the antenna are connected to spring 8 (the antenna)).

*Important: If any parts are missing or damaged, go to [elenco.com/replacement-parts](http://elenco.com/replacement-parts) or e-mail us at [support@elenco.com](mailto:support@elenco.com) if you need further assistance. DO NOT contact your place of purchase as they will not be able to help you.*



---

## NOTES

---

## NOTES

---

## NOTES

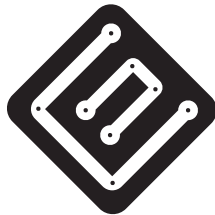

**ELENCO<sup>®</sup>**  
Learn by doing.<sup>®</sup>

**Elenco Electronics, LLC.**  
150 Carpenter Avenue  
Wheeling, IL 60090  
[www.elenco.com](http://www.elenco.com)