

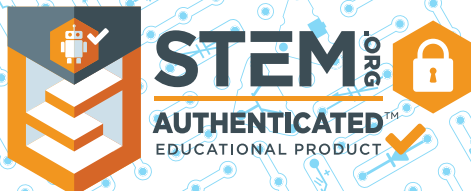
SNAP CIRCUITS

ELENCO

Home Learning Electronic Fun



Student Activity Guide



An introduction to the exciting world of electronics

Table of Contents

Basic Troubleshooting	1	Summary of Parts & Circuit Diagram Symbols	6-8
Parts List	2	List of Lessons Sections	9
How to Use It	3	Lessons and Activities	10-61
DOs and DON'Ts of Building Circuits	4	Defenition of Terms	62-63
Advanced Troubleshooting	5	Test your Knowledge	64-66



WARNING TO ALL PARTS WITH A ⚠ SYMBOL - Moving parts. Do not touch the motor or fan during operation. Do not lean over the motor. Do not launch the fan at people, animals, or objects. Eye protection is recommended.



WARNING: SHOCK HAZARD - Never connect Snap Circuits® to the electrical outlets in your home in any way!



WARNING: CHOKING HAZARD - Small parts. Not for children under 3 years.

Conforms to ASTM F963-96A

Meets academic standards for elementary science.

WARNING: Always check your wiring before turning on a circuit. Never leave a circuit unattended while the batteries are installed. Never connect additional batteries or any other power sources to your circuits. Discard any cracked or broken parts.

Adult Supervision: Because children's abilities vary so much, even with age groups, adults should exercise discretion as to which experiments are suitable and safe (the instructions should enable supervising adults to establish the experiment's

suitability for the child). Make sure your child reads and follows all of the relevant instructions and safety procedures, and keeps them at hand for reference.

This product is intended for use by adults and children who have attained sufficient maturity to read and follow directions and warnings.

Never modify your parts, as doing so may disable important safety features in them, and could put your child at risk of injury.

Basic Troubleshooting

1. Most circuit problems are due to incorrect assembly, always double-check that your circuit exactly matches the drawing for it.
2. Be sure that parts with positive/negative markings are positioned as per the drawing.
3. Be sure that all connections are securely snapped.
4. Try replacing the batteries.
5. If the motor spins but does not balance the fan, check the black plastic piece with three prongs on the motor shaft. Be sure that it is at the top of the shaft.

ELENCO® is not responsible for parts damaged due to incorrect wiring.

Note: If you suspect you have damaged parts, you can follow the Advanced Troubleshooting procedure on page 5 to determine which ones need replacing.











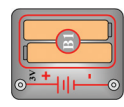

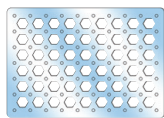












Batteries:

- Use only 1.5V AA type, alkaline batteries
- Insert batteries with correct polarity.
- Non-rechargeable batteries should not be recharged. Rechargeable batteries should only be charged under adult supervision, and should not be recharged while in the product.
- Do not mix alkaline, standard (carbon-zinc), or rechargeable (nickel-cadmium) batteries.
- Do not mix old and new batteries.
- Remove batteries when they are used up.
- Do not short circuit the battery terminals.
- Never throw batteries in a fire or attempt to open its outer casing.
- Batteries are harmful if swallowed, so keep away from small children.

Parts List (Colors and styles may vary) Symbols and Numbers

Important: If any parts are missing or damaged, **DO NOT RETURN TO RETAILER.** Call toll-free (800) 533-2441 or e-mail us at: help@elenco.com. Customer Service: 150 Carpenter Ave., Wheeling, IL 60090

Qty.	ID	Name	Symbol	Part #	Qty.	ID	Name	Symbol	Part #
□ 2	②	2-Snap Wire		6SC02	□ 1		Fan		6SCM1F
□ 2	③	3-Snap Wire		6SC03	□ 1	Ⓜ3	Electromagnet		6SCM3
□ 1	④	4-Snap Wire		6SC04	□ 1		Iron Core Rod		6SCM3B
□ 1	⑤	5-Snap Wire		6SC05	□ 1	Ⓚ2	NPN Transistor		6SCQ2
□ 1	⑥	6-Snap Wire		6SC06	□ 1	Ⓜ1	100Ω Resistor		6SCR1
□ 1	Ⓚ1	Battery Holder - uses 2 1.5V type AA (not included)		6SCB1	□ 1	Ⓜ5	100kΩ Resistor		6SCR5
□ 1		Base Grid (11.0" x 7.7")		6SCBG	□ 1	ⓂP	Photoresistor		6SCRP
□ 1	Ⓚ1	Red Light Emitting Diode (LED)		6SCD1	□ 1	Ⓜ1	Slide Switch		6SCS1
□ 1		Jumper Wire (Black)		6SCJ1	□ 1	Ⓜ2	Press Switch		6SCS2
□ 1		Jumper Wire (Red)		6SCJ2	□ 1	ⓂP	Speaker		6SCSP
□ 1	Ⓚ1	Lamp, 3V		6SCL1	□ 1	Ⓜ1	Music Integrated Circuit		6SCU1
□ 1	Ⓜ1	Motor		6SCM1	You may order additional / replacement parts at our website: www.elenco.com/replacement-parts				

How to Use It

The Electronic Snap Circuits® Home Learning Kit has 30 projects. They are simple to build and understand.

The Snap Circuits® kit uses building blocks with snaps to build the different electrical and electronic circuits in the projects. Each block has a function: there are switch blocks, lamp blocks, battery blocks, different length wire blocks, etc. These blocks are in different colors and have numbers on them so that you can easily identify them. The circuit you will build is shown in color and with numbers, identifying the blocks that you will use and snap together to form a circuit.

For Example:

This is the switch block which is green and has the marking (S1) on it as shown in the drawings.

Please note that the drawing doesn't reflect the real switch block exactly (it is missing the ON and OFF markings), but gives you the general idea of which part is being used in the circuit.



This is a wire block which is blue and comes in different wire lengths.

This one has the number (2), (3), (4), (5), or (6) on it depending on the length of the wire connection required.



To build each circuit, you have a power source block number (B1) that needs two (2) "AA" batteries (not included with the Snap Circuits® kit). When installing a battery, be sure the spring is compressed straight back, and not bent up, down, or to one side.



A large clear plastic base grid is included with this kit to help keep the circuit blocks properly spaced. You will see evenly spaced posts that the different blocks snap into. You do not need this base to build your circuits, but it does help in keeping your circuit together neatly. The base has rows labeled A-G and columns labeled 1-10.

Next to each part in every circuit drawing is a small number in black. This tells you which level the component is placed at. Place all parts on level 1 first, then all of the parts on level 2, then all of the parts on level 3, etc.

Place the fan on the motor (M1) whenever that part is used, unless the project you are building says not to use it.

Some circuits use the jumper wires to make unusual connections. Just clip them to the metal snaps or as indicated.



Note: While building the projects, be careful not to accidentally make a direct connection across the battery holder (a "short circuit"), as this may damage and/or quickly drain the batteries.

DOs and DON'Ts of Building Circuits

After building the circuits given in this booklet, you may wish to experiment on your own. Use the projects in this booklet as a guide, as many important design concepts are introduced throughout them. Every circuit will include a power source (the batteries), a resistance (which might be a resistor, lamp, motor, integrated circuit, etc.), and wiring paths between them and back. **You must be careful not to create "short circuits" (very low-resistance paths across the batteries, see examples below) as this will damage components and/or quickly drain your batteries.** Only connect the IC using configuration given in the projects, incorrectly doing so may damage it. **ELENCO® is not responsible for parts damaged due to incorrect wiring.**

Here are some important guidelines:

ALWAYS use eye protection when experimenting on your own.

ALWAYS include at least one component that will limit the current through a circuit, such as the speaker, lamp, electromagnet, music IC (which must be connected properly), motor, photoresistor, or resistor.

ALWAYS use the LED and switches in conjunction with other components that will limit the current through them. Failure to do so will create a short circuit and/or damage those parts.

ALWAYS disconnect your batteries immediately and check your wiring if something appears to be getting hot.

ALWAYS check your wiring before turning on a circuit.

ALWAYS connect the music IC using configurations given in the projects or as per the connection descriptions for it.

NEVER connect to an electrical outlet in your home in any way.

NEVER leave a circuit unattended when it is turned on.

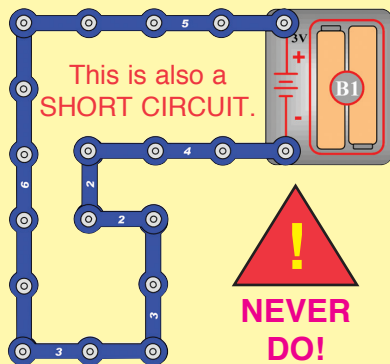
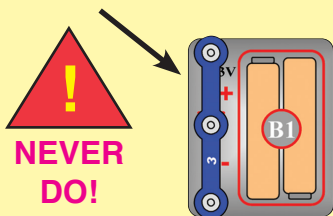
NEVER touch the motor when it is spinning at high speed.

WARNING: SHOCK HAZARD - Never connect your Snap Circuits® set to the electrical outlets in your home in any way!

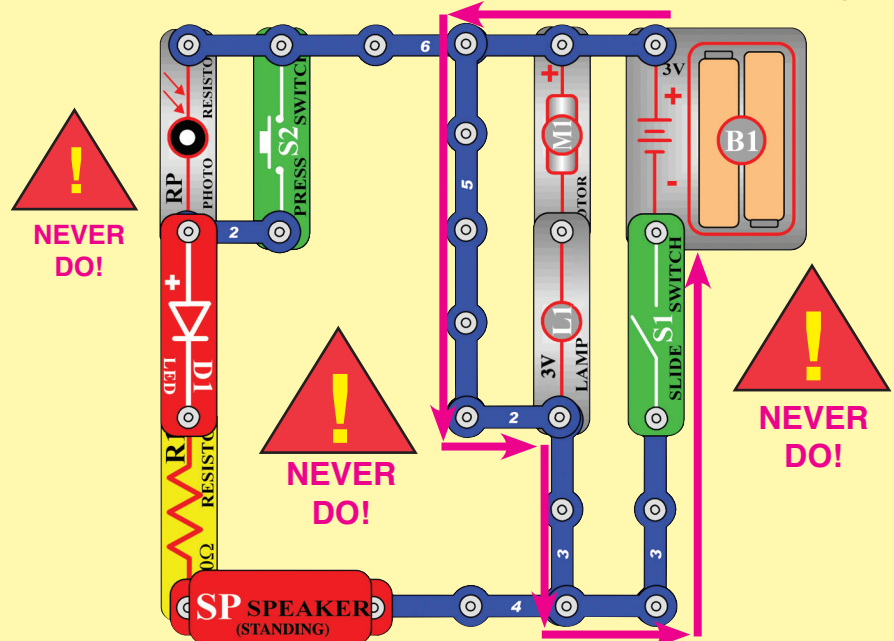
For all of the projects given in this book, the parts may be arranged in different ways without changing the circuit. For example, the order of parts connected in series or in parallel does not matter — what matters is how combinations of these sub-circuits are arranged together.

Examples of SHORT CIRCUITS - NEVER DO THESE!!!

Placing a 3-snap wire directly across the batteries is a **SHORT CIRCUIT**.



When the slide switch (S1) is turned on, this large circuit has a **SHORT CIRCUIT** path (as shown by the arrows). The short circuit prevents any other portions of the circuit from ever working.



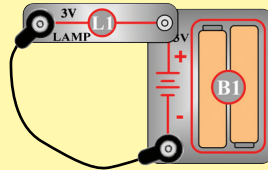
Advanced Troubleshooting (Adult supervision recommended)

ELENCO® is not responsible for parts damaged due to incorrect wiring.

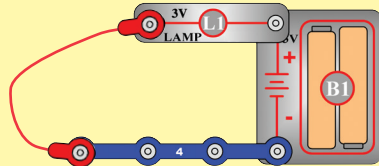
If you suspect you have damaged parts, you can follow this procedure to systematically determine which ones need replacing:

1. **Lamp (L1), motor (M1), speaker (SP), and battery holder (B1):** Place batteries in holder. Place the lamp directly across the battery holder, it should light. Do the same with the motor (motor + to battery +), it should spin to the right at high speed. "Tap" the speaker across the battery holder contacts, you should hear static as it touches. If none work then replace your batteries and repeat, if still bad then the battery holder is damaged.

2. **Jumper wires:** Use this mini-circuit to test each jumper wire, the lamp should light.



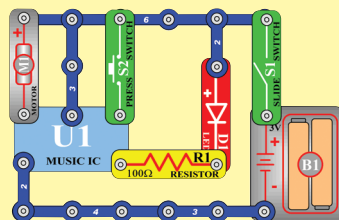
3. **Snap wires:** Use this mini-circuit to test each of the snap wires, one at a time. The lamp should light.



4. **Slide switch (S1) and Press switch (S2):** Build activity 1, if the lamp (L1) doesn't light then the slide switch is bad. Replace the slide switch with the press switch to test it.

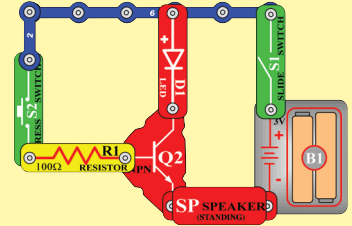
5. **100Ω resistor (R1) and LED (D1):** Build the circuit in activity 16 on page 38 except initially use the speaker (SP) in place of the LED, you will hear static if the resistor is good. Then replace the speaker with the LED and see that it lights.

6. **Music IC (U1):** Build the circuit shown here. Turn it on and the LED (D1) flickers for a while and stops, it should resume if you spin the motor (M1) or push the press switch (S2).



7. **NPN transistor (Q2), 100kΩ resistor (R5), and Photoresistor (RP):** Build the mini-circuit shown here. The LED (D1) should only be on if the press switch (S2) is pressed; if otherwise then the NPN is damaged.

- Replace the 100Ω resistor (R1) with the 100kΩ resistor (R5). The LED should light when the press switch is pressed; otherwise the 100kΩ resistor is damaged.



- Replace the 100kΩ resistor with the photoresistor. The LED should light when the press switch is pressed and there is light on the photoresistor; otherwise the photoresistor is damaged.

8. **Electromagnet (M3):** Use the circuit for the circuit in activity 31 on page 55, and place the iron core rod in the electromagnet. When you push the press switch (S2), a metal paperclip or small iron nail should be attracted to the iron core rod; if no attraction then the electromagnet is damaged.

ELENCO®

150 Carpenter Avenue
Wheeling, IL 60090 U.S.A.

Phone: (847) 541-3800


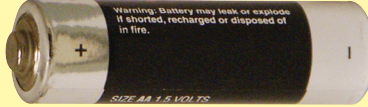
Fax: (847) 520-0085



e-mail: help@elenco.com



Website: www.elenco.com


You may order additional /
replacement parts at:
www.elenco.com/replacement-parts

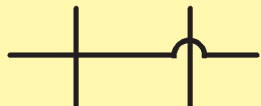
Summary of Parts & Circuit Diagram Symbols

<p>Dry Cell</p>		<p>Produces electrical energy using a chemical reaction. The larger terminal (on the left) is positive (+). A single cell is often called a battery, but strictly a battery is two or more cells joined together.</p> 
------------------------	---	---



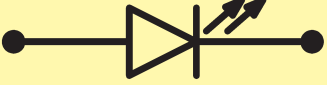


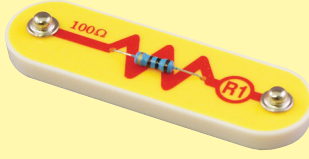

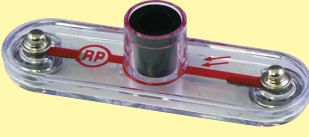

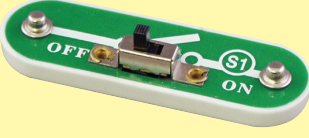


<p>2 Cell Battery (B1)</p>		<p>Batteries supply electrical energy. A battery is more than one cell.</p> 
-----------------------------------	---	---

<p>Wire (2, 3, 4, 5, & 6 snap wires, red and black jumper wires)</p>		<p>Used to pass current very easily from one part of a circuit to another. A 3-snap wire is shown here.</p> 
---	---	---

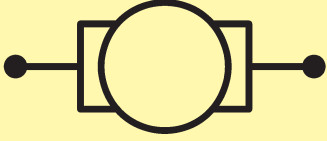

<p>Wires joined</p>		<p>A 'blob' should be drawn where wires are connected (joined), but it is sometimes omitted. Wires connected at 'crossroads' should be staggered slightly to form two T-junctions, as shown on the right.</p>
----------------------------	---	---

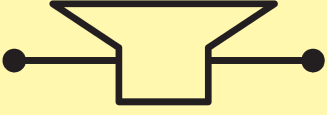

<p>Wires not joined</p>		<p>In complex diagrams it is often necessary to draw wires crossing even though they are not connected. Often the 'bridge' symbol shown on the right is used because the simple crossing on the left may be misread as a join where you have forgotten to add a 'blob'!</p>
--------------------------------	---	---

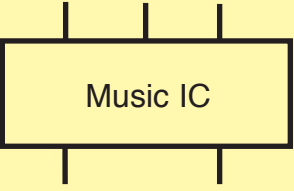

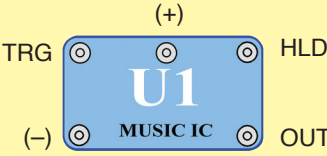
Summary of Parts & Circuit Diagram Symbols



<p>Lamp (L1)</p>		<p>A transducer that converts electrical energy to light. It contains a special wire that glows bright when a large electric current passes through it. The upper symbol is used for a lamp providing illumination, for example a car headlamp or flashlight bulb.</p> 
<p>LED (D1) Light Emitting Diode</p>		<p>A transducer that converts electrical energy to light.</p> 
<p>Resistor (R1 100Ω and R5 100kΩ)</p>		<p>A resistor restricts the flow of current through a circuit.</p> 
<p>Photoresistor (RP)</p>		<p>A resistor whose value changes as light shines on it.</p> 
<p>On-Off Switch (S1)</p>		<p>A mechanical switch that allows current to flow only when it is in the closed (on) position.</p> 
<p>Push Switch (push-to-connect S2)</p>		<p>A push switch allows current to flow only when the button is pressed.</p> 



Summary of Parts & Circuit Diagram Symbols

<p>Motor (M1)</p>		<p>A transducer that converts electrical energy to kinetic energy (motion).</p> 
--------------------------	---	---

<p>Speaker (SP)</p>		<p>A transducer that converts electrical energy to sound. An electrical signal creates mechanical vibrations, which create variations in air pressure, which travel across the room to your ears.</p> 
----------------------------	---	---

<p>Music Integrated Circuit (U1)</p>		<p>A module that converts electrical energy to Music. It contains a specialized sound-generation circuit with resistors, capacitors, and transistors. The descriptions for the music IC module is given here for those interested, see the projects for connection examples:</p>  <p>Music IC: (+) - power from batteries (-) - power return to batteries OUT - output connection HLD - hold control input TRG - trigger control input</p> <p>Music for ~20 sec on power-up, then hold HLD to (+) power or touch TRG to (+) power to resume music.</p> 
---	---	---

<p>Electromagnet (M3) with Iron Core Rod</p>		<p>A coil of wire, which acts like a magnet when an electric current flows through it. Placing an iron bar inside increases the magnetic effects.</p> 
---	---	---

<p>NPN Transistor (Q2)</p>		<p>A device that switches or amplifies electrical current.</p> 
-----------------------------------	---	--

List of Lessons Sections

Preface	10	3-7 Resistance of Water	45
		<i>Includes one circuit activities</i>	
Chapter 1: Basic Components & Circuits	10	3-8 Introduction to Logic	46
<i>Introduces electricity with the components and circuit types listed here. By building circuits using Snap Circuits[®], students begin to understand the electrical world.</i>		<i>Includes five circuit activities</i>	
1-1 Electricity	11	3-9 Digital Electronics	48
1-2 Wires	12	Summary & Quiz	49
1-3 Batteries	13	Chapter 4: Other Electrical Components & Circuits	50
1-4 Switches	14	<i>Students learn how electricity makes sound. They also learn about the integrated circuit modules included in Snap Circuits[®] and what is inside them. They have the opportunity to use ICs in many types of circuits.</i>	
1-5 Lamps	14	4-1 Schematics	50
1-6 Base Grid	15	<i>Includes three circuit activities</i>	
<i>Includes two circuit activities</i>		4-2 Transistors	51
1-7 Series and Parallel Circuits	19	<i>Includes one circuit activities</i>	
<i>Includes two circuit activities</i>		4-3 Electromagnetism	53
1-8 Short Circuits	21	<i>Includes one circuit activities</i>	
1-9 Solder	21	4-4 Integrated Circuits	57
Summary & Quiz	22	<i>Includes five circuit activities</i>	
Chapter 2: Motors & Electricity	23	Summary & Quiz	61
<i>Students learn how electricity and magnetism are used in motors and generators, about the electricity that runs their homes, and about lightning.</i>			
2-1 Motors	24		
<i>Includes one circuit activity</i>			
2-2 Motor Circuits	26		
<i>Includes six circuit activities</i>			
2-3 Fuses	30		
<i>Includes one circuit activity</i>			
2-4 Your Electric Company	31		
<i>Includes three circuit activities</i>			
2-5 Static Electricity	33		
2-6 Types of Lamps	34		
2-7 Types of Switches	34		
2-8 Electricians	34		
Summary & Quiz	35		
Chapter 3: Resistance & Electronic Sound	36		
<i>Students learn how resistors are used to limit and control the flow of electricity, and how electricity makes sound. They also learn the basic rules for understanding circuits, and receive an introduction to digital electronics.</i>			
3-1 Resistors	37		
3-2 LEDs	37		
<i>Includes two circuit activities</i>			
3-3 The Photoresistor	39		
<i>Includes one circuit activity</i>			
3-4 Resistors in Series and Parallel	39		
<i>Includes three circuit activities</i>			
3-5 Resistance	41		
<i>Includes one circuit activity</i>			
3-6 Electronic Sound	43		
<i>Includes two circuit activities</i>			

PREFACE

This booklet is an introduction to the exciting world of electronics. Following the “Learn by Doing®” concept, electronics will be easy to understand by using Snap Circuits® to actually build circuits as you learn about them. This booklet emphasizes the practical applications of electronics, without bogging down in mathematics.

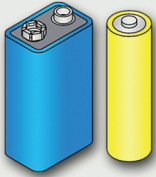
Why learn about electronics? Electronics plays an important and increasing role in our everyday lives, and so some basic knowledge of it is good

for everyone. Learning about it teaches how to do scientific investigation, and the projects develop basic skills needed in today’s world.

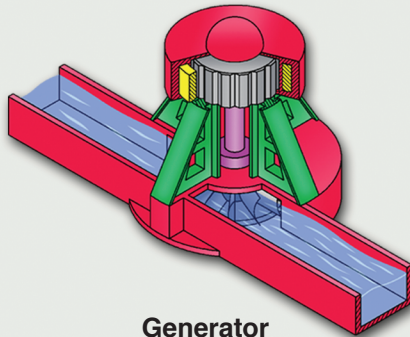
Much of the text in all chapters is color-coded green and blue so that instructors can easily adapt the course based on the skills and interests of the students. The orange boxes are more advanced material while the brown boxes are considered additional/background material, either can generally be omitted without a significant impact on the course.

CHAPTER 1: BASIC COMPONENTS & CIRCUITS

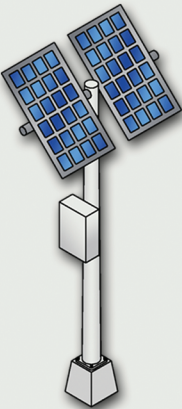
What is electricity? Nobody really knows. We only know how to produce it, understand its properties, and how to control it. It can be created by chemistry (batteries), magnetism (generators), light (solar cells), friction (rubbing a sweater), and pressure (piezoelectric crystals).



Batteries



Generator



Solar Cells



Rubbing a Sweater



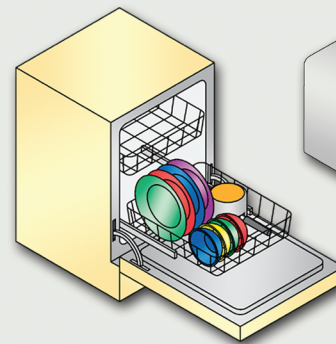
Piezoelectric Crystal

In this section you will learn about basic electrical components and circuits. By building circuits using Snap Circuits®, you will begin to understand the electrical world.

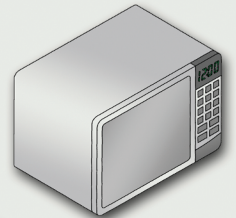
Electricity is energy that can be used to save us effort (electric toothbrushes and dishwashers), heat things (electric heaters and microwave ovens), make light (light bulbs), and send information (radio and television). But electricity can also be dangerous if abused (electric shock).



Electric Toothbrush



Dishwasher



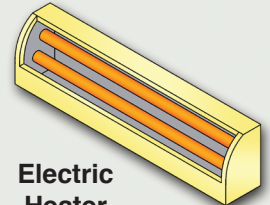
Microwave Oven



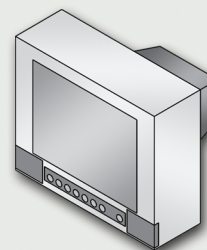
Light Bulb



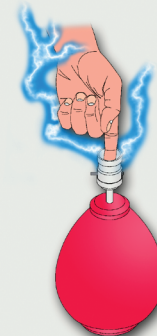
Radio



Electric Heater



Television

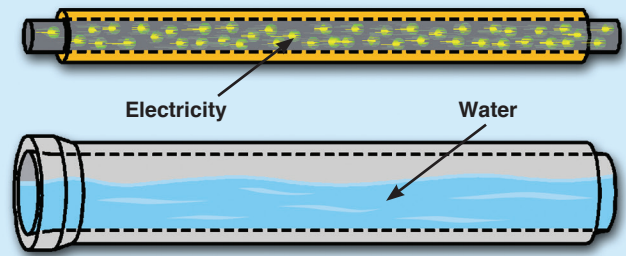


Electric Shock

1 - 2 WIRES

Wires can be thought of as large, smooth pipes that allow water to pass through easily. Wires are made of metals, usually copper, that offer very low resistance to the flow of electricity.

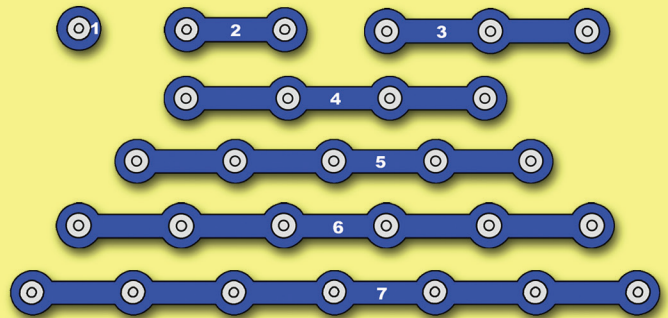
The **electric current** is a measure of how fast electricity is flowing in a wire, just as the water current describes how fast water is flowing in a pipe. It is expressed in **amperes** (A, named after Andre Ampere who studied the relationship between electricity and magnetism) or **milliamps** (mA, 1/1000 of an ampere).



With Snap Circuits® the wires you will use have been shaped into snap wire strips, to make interconnection easy. These work the same as any other wires you might find in your house, since they are made of metal.

INTRODUCING NEW PARTS

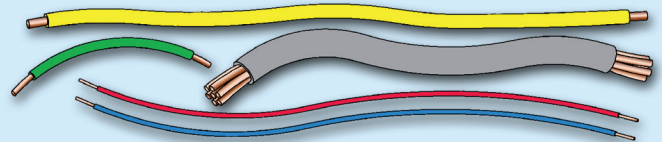
If you have the Snap Circuits® parts nearby then pull out the wires and look at them. They have numbers such as 2, 3, 4, 5, 6 or 7 depending on the length of the wire connection. There is also a 1-snap wire that is used as a spacer or for interconnection between different layers.



Wires can generally be as long as desired without affecting circuit performance, just as using garden hoses of different lengths has little effect on the water pressure as you water your garden. However there are cases where the length and size of a pipe does matter, such as in the water lines for your entire city or in an oil refinery. Similarly, wire length and size are important for electric power lines transporting electricity from a power plant in a remote area to a city, and in circuits used in radio or satellite communication.

If you were to look inside an electronic device in your home (make sure it's not plugged in) you might see a lot of wires of different colors. The actual wires are all the same color of metal, but they have a protective covering over them. The colors are used to easily identify which wire is which during assembly and repair of the circuit.

The covering is also used to prevent different parts of a circuit from connecting accidentally.

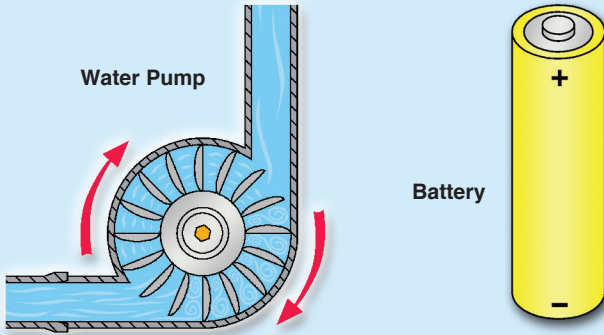


Try to imagine the total length of wire used in all the products in your home!

1 - 3 BATTERIES

To make water flow through a pipe we need a pump. To make electricity flow through wires we use a battery. A battery creates an electrical charge across wires. It does this by using a chemical reaction and has the advantage of being simple, small, and portable.

Voltage is a measure of how strong the electric charge from your battery is, and is similar to the water pressure. It is expressed in volts (V, and named after Alessandro Volta who invented the battery in 1800). Notice the “+” and “-” signs on the battery. These indicate which direction the battery will “pump” the electricity, similar to how a water pump can only pump water in one direction.

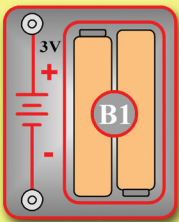


The 0V or “-” side of the battery is often referred to as “**ground**”, since in house or building wiring it is connected to a rod in the ground as protection against lightning.

Battery power is much easier to use in electronics than the electricity that powers your home. This is because most electronic circuits only need a low voltage source to operate; all the electricity produced by your electric company comes at a higher voltage, which must be converted down. If a circuit is given too much voltage then its components will be damaged. It is like having the water in your faucet come out at higher pressure than you need, and it splashes all over the room. If water in a pipe is at too high of pressure then the pipe may burst. Batteries are selected to give your circuit just the voltage it needs.

INTRODUCING NEW PARTS

Your Snap Circuits® uses one set of two 1.5V batteries in a holder (snap part B1, actual batteries are not included). Notice that just to the right of the battery holder pictured below is a symbol, the same symbol you see on the battery holder. Engineers are not very good at drawing pictures of their parts, so when engineers draw pictures of their circuits they use symbols like this to represent them.



Battery Holder (B1)



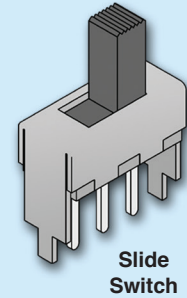
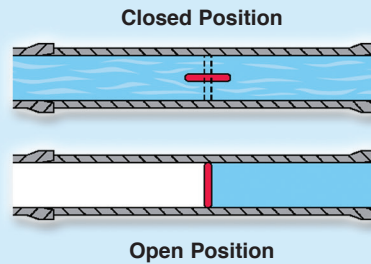
Battery Symbol

Batteries are made from materials like zinc and magnesium dioxide, electricity flows as these react with each other. As more material is used up by the reaction, the battery voltage is slowly reduced until eventually the circuit no longer functions and you have to replace the batteries. Some batteries, called rechargeable batteries (such as the batteries in your cell phone), allow you to reverse the chemical reaction using another electric source. That way the batteries can last through years of use.

Try to count how many batteries are in your home, your count will probably be low. Many products that use your house power also have batteries to retain clock or programmed information during brief power outages (such as computers and DVD players).

1 - 4 THE SWITCH

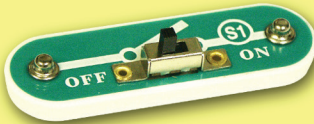
Since you don't want to waste water when you are not using it, you have a faucet or valve to turn the water on and off. Similarly, you use a switch to turn the electricity on and off in your circuit. A switch connects (the "closed" or "on" position) or disconnects (the "open" or "off" position) the wires in your circuit.



Slide Switch

INTRODUCING NEW PARTS

Just as the plumbing industry has a wide range of valves for different situations, there are many types of switches used in electronics. The type shown below is called a slide switch, because you slide it back and forth to turn it on and off. Snap Circuits® includes one of these (part S1), shown below. As with the battery, the slide switch is represented by a symbol, shown to its right. If you have the snap circuits parts nearby, take out the switch and look at it.



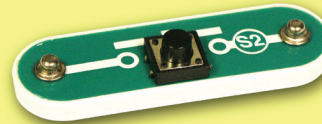
Slide Switch (S1)



Slide Switch Symbol

INTRODUCING NEW PARTS

Another type of switch is the press switch, and Snap Circuits® also includes one of these (part S2). When you press down the two pieces of metal touch, so electricity can flow. When you let go of it, the electricity stops. Its symbol is marked on the snap part, though on many professional electronics drawings both slide and press switches use the symbol for the slide switch because they really perform the same function.



Press Switch (S2)



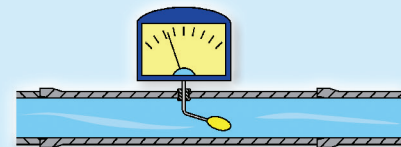
Press Switch Symbol

You can think of slide and press switches like the water faucet in your kitchen (which pours out water until you turn it off) and a water fountain in a school or movie theater (which only squirts out water as long as you are pressing the button).

Switches in modern electronics come in many diverse forms. Try to count how many are in your home or car; you will be amazed. There are slide, press, membrane, rotary, push-button, and other switches controlling nearly everything.

1 - 5 THE LAMP

In a **lamp** electricity is converted into light, the brightness of the lamp increases as more electric current flows through it. You can think of a lamp as a water meter, since it is showing us how much current is flowing in a circuit just as a water meter shows how much water is flowing in a pipe.



Water Meter

INTRODUCING NEW PARTS

Snap Circuits® includes a lamp (part L1, shown below). If you have the parts with you, take it out and look at it.



3V Lamp (L1)

Just as there are different types of water meters to work with different pressures and volumes of water, there are also different lamps. Lamp L1 is a low-pressure meter, and works with voltages

(electrical pressures) of up to 3V. Higher voltages than that will damage the bulb, so always make sure to use the correct lamp.

The electrical symbol for a lamp is shown here, it is the same for both lamps but the voltage will be indicated as needed. The lamp sockets are the same for both parts; only the bulbs and markings are different.



Lamp Symbol

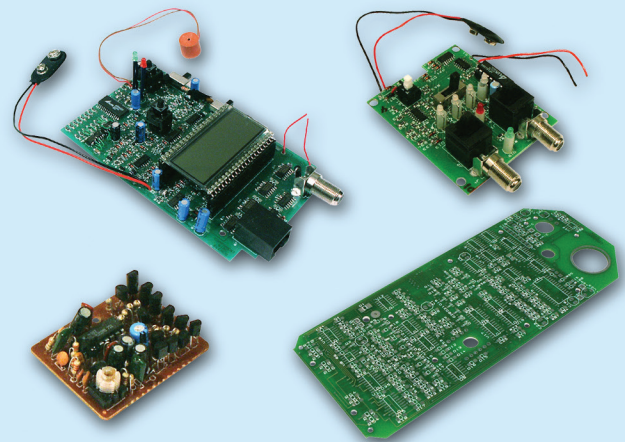
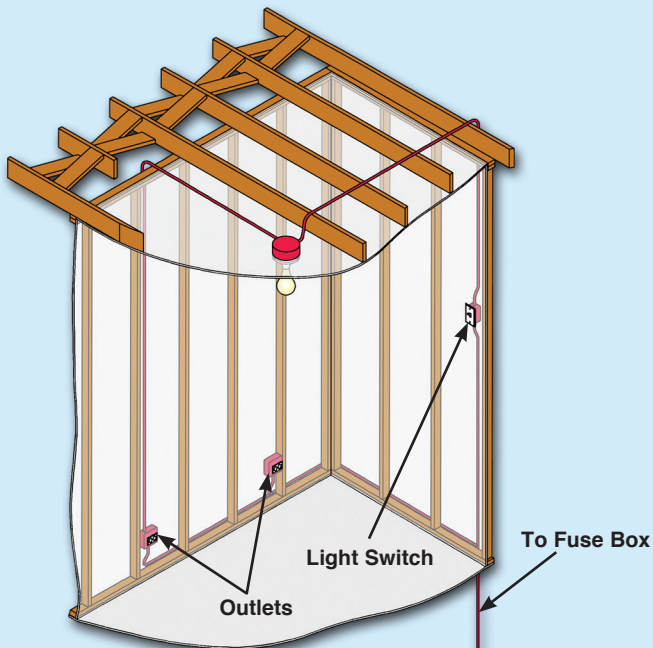
While occasionally lamps are used to indicate how much electricity is flowing in a circuit, they are mostly used to light our homes, businesses, and streets. Although scientists had been experimenting with electricity for years, the first practical use of electricity occurred when inventor Thomas Edison used it to light a bulb similar to these. For many

years electricity was used almost exclusively for lighting. That has since changed. Now only a small percentage of the electricity produced in the United States is used for lighting with the rest going to a vast range of uses in everyday life that Edison would never have imagined.

1 - 6 BASE GRID

The water in your home flows through pipes mounted in the walls and floors of your home, and similarly the electricity in your house flows through wires mounted in the walls and ceilings of your home. But the wires in your walls take a lot of hard work to install and then can't be moved.

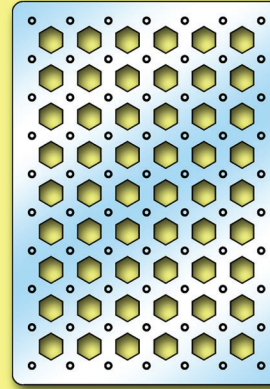
Most products that use electricity are small, easy to move, and easy to build. That is because they have almost all of their components and wires mounted on "circuit boards" such as these:



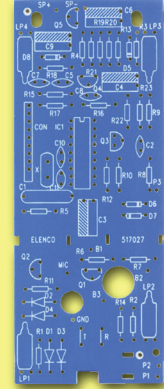
Boards like these are used in almost all electronic products, look inside any radio or computer and you will find them. Note that the "wires" connecting parts mounted on the circuit board are literally "printed" on the surface of the board; hence circuit boards all are called "printed circuit boards" or PCBs.

INTRODUCING NEW PARTS

In the same manner Snap Circuits® uses a clear plastic base grid with evenly spaced posts to mount the snap parts and wires and to keep them together neatly. It has rows labeled A-G and columns labeled 1-10 to easily identify points in your circuit. You don't need the base to build your circuits, but just try building one of the larger circuits without it! The base grid is shown here, next to a picture of a typical circuit industry board before parts are mounted.

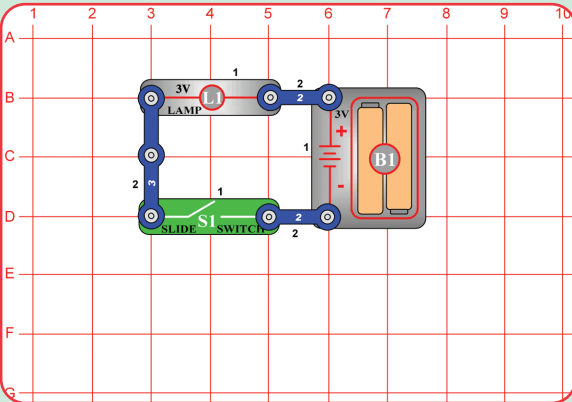


Base Grid



PC Board

ACTIVITY 1 Electric Light and Switch

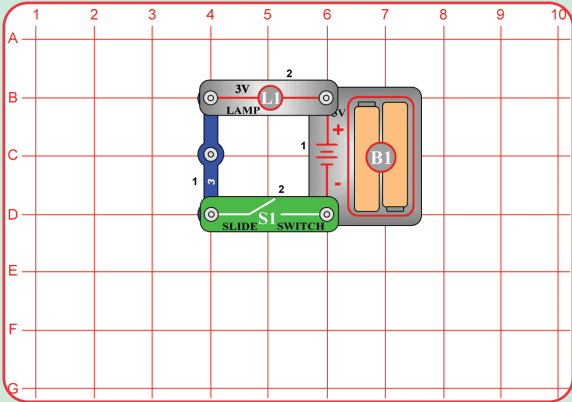


So far we've talked about wires, batteries, switches, lamps, and circuit boards; now it's time to put them together to form a circuit.

Build the circuit shown on the left by placing the parts with a black 1 next to them on the board first. Then add the parts with a 2. Install two AA type batteries (not included) in the holder (B1).

What happens when you close the switch? _____

What happens when you open the switch? _____



Now build this circuit with some of the same parts.

What do the two circuits have in common? _____

How can you tell when electricity is flowing through the circuit? _____

Explain how the switch works. _____

What would you do to open and close this circuit without a switch? _____

Give two examples of switches used in everyday life.

1. _____
2. _____

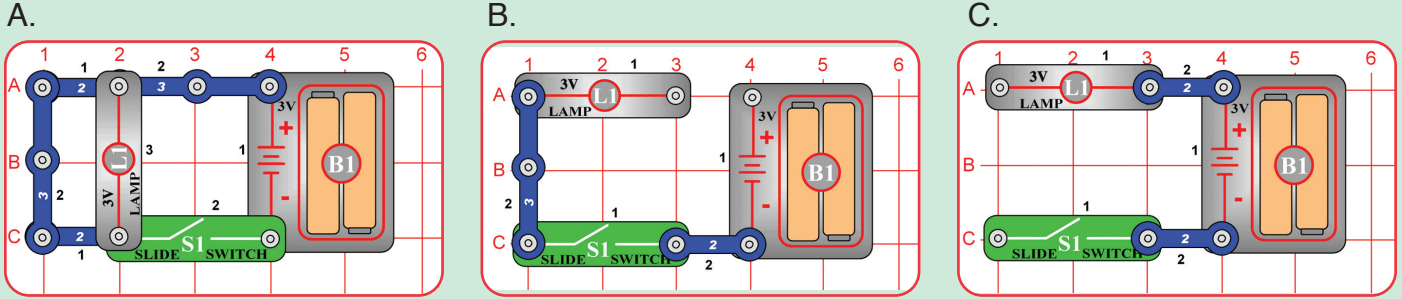
ACTIVITY 1 Electric Light and Switch

Use the circuit diagram symbols introduced on pages 6-8 to draw the two circuits you have made on the previous page.

Diagram 1

Diagram 2

Tell why these three circuits will not light the bulb, then explain a way to fix the circuits.



Circuit A will not light the bulb because

Repair by: _____

Circuit B will not light the bulb because

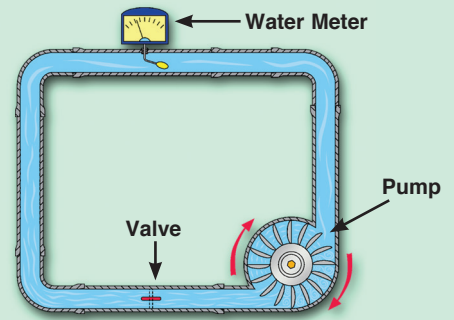
Repair by: _____

Circuit C will not light the bulb because

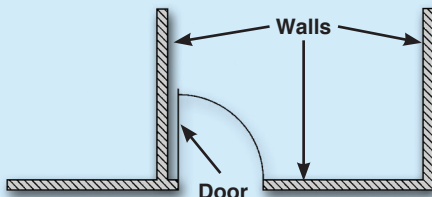
Repair by: _____

Turning on the switch turns on the lamp. This circuit is the same circuit used to turn on a lamp in your home. The only differences are the batteries are really power from the electric company, the lamp is larger and bright enough to light up the room, the switch is really a switch on the wall, and the snap wires are really wires in the wall and the cord to the lamp.

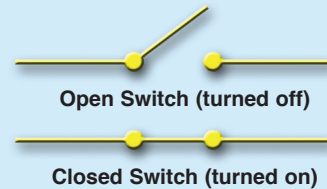
You can think of the electricity flowing through the battery, lamp, switch, and wires in the above circuit as if it were water flowing through a pump, water meter, valve, and pipes:



In electronics, the “on” position of a switch is also called the “closed” position. Similarly, the “off” position is also called the “open” position. This is because the symbol for a slide switch is similar to the symbol for a door in an architect’s drawing of a room:

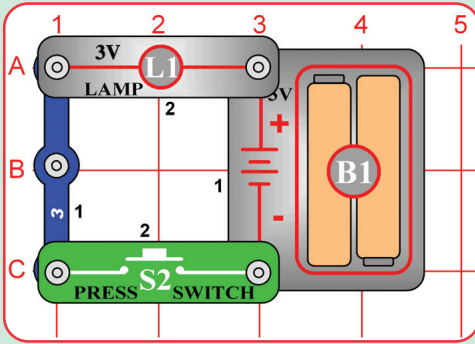


The electronics symbol for a slide switch should be thought of as a door to a circuit, which swings open when the switch is off. The “door” to the circuit is closed when the switch is on. This is shown here in drawings using the part symbols:



ACTIVITY 2 Morse Code

Since December 2003, Morse Code has included the @ symbol: it is a combination of a and c: o--o-o and is the first change to the system since before World War II.



Letters

•	•••	•••	•••	•	••••	••••	••	•••	•••	•••
a	b	c	d	e	f	g	h	i	j	k
••••	••	••	•••	••••	•••	•••	•••	-	•••	••••
l	m	n	o	p	q	r	s	t	u	v
•••	••••	•••	••••	••••	••••	••••	••••	••••	••••	••••
w	x	y	z	ä	á	ch	é	ñ	ö	ü

Punctuation

••••	•••••	•••••	•••••	•••••	•••••
fullstop/ period	comma	question mark	apostrophe	exclamation mark	slash
•••••	•••••	•••••	•••••	•••••	•••••
hyphen	fraction bar	parentheses	quotation marks		

Numbers

•••••	•••••	•••••	•••••	•••••	•••••	•••••	•••••	•••••	•••••	•••••
1	2	3	4	5	6	7	8	9	0	

You can send a message to your partner using Morse code shown in the box above. At first you should only use the letters from a to z and the numbers. Morse code is a series of dots and dashes representing the letters of the alphabet. A telegraph sends messages with sound signals. Your sender uses light instead. If you only hold down the press switch for a short time, you get a “dot”. If you hold the switch down for a longer time you get a “dash”.

Using the code, write a sentence to send to your partner. Remember to pause between words. Since your partner is new to decoding Morse code, try to send your message slowly so your partner has time to write it down. After your partner decodes your message, your partner will write a message to send to you to decode.

How does a telegraph work? _____

How is your telegraph similar to an actual telegraph? _____

How is it different? _____

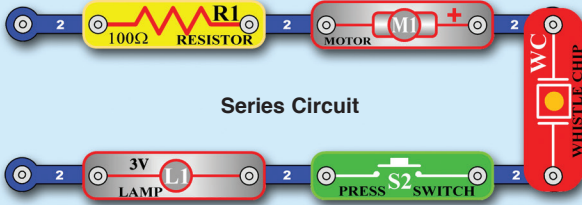
Why were telegraphs important in the past? _____

Why are telegraphs less important today? _____

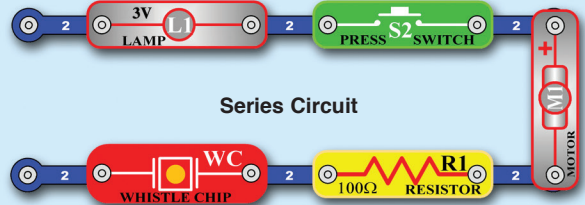
Name two devices used for communication over great distances. _____

1 - 7 SERIES VS. PARALLEL CIRCUITS

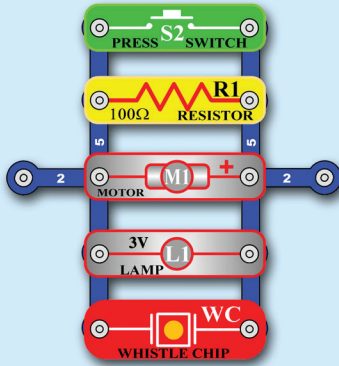
There are two ways of arranging parts in a circuit, in series or in parallel. Here are examples:



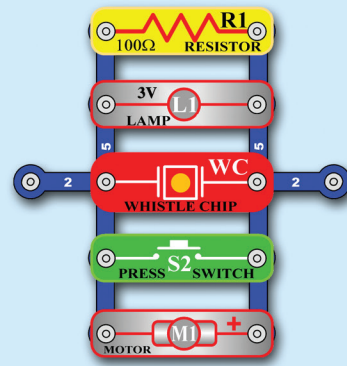
Series Circuit



Series Circuit

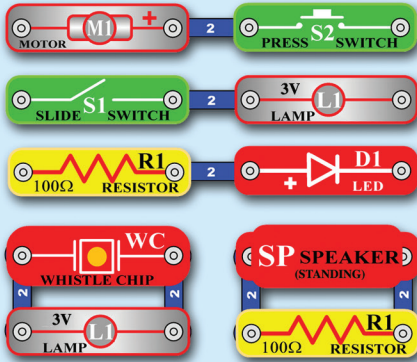


Parallel Circuit

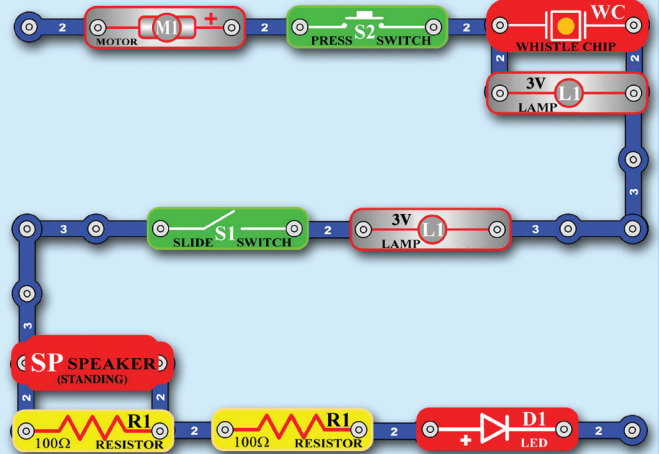


Parallel Circuit

Large circuits are made of combinations of smaller series and parallel circuits. For example, these small sub-circuits:

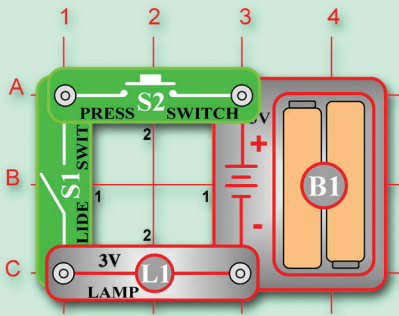


... may be combined into this larger circuit:



ACTIVITY 3

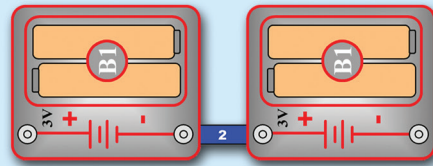
Consider this mini-circuit:



If both switches are on, the lamp will light. If one switch is off then the lamp will be off, because the switches are in series.

If you connected several lamps in series then one switch would turn them all on or off. But if one of the bulbs was broken then none would light. Strings of inexpensive Christmas lights are wired in series; if one bulb is damaged then the entire string does not work.

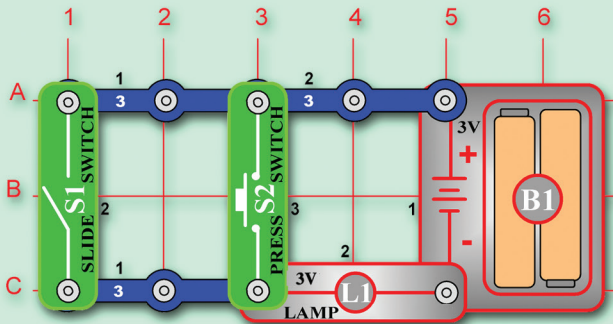
Note that battery holder B1 has two 1.5V batteries connected in series, these add together to produce 3V. If you had several battery holders, you could connect them in series to get higher voltages:



$$3V + 3V = 6V$$

ACTIVITY 4

Consider this mini-circuit:



If either switch is on, the lamp will light. If one switch is off then the lamp will still be on, because the switches are in parallel.

In this circuit you could swap the locations of the switches with each other (because they are both in parallel) or the batteries with the lamp (they are both in series), but if you swap the lamp with one of the switches then the circuit will be different. All electric circuits are made up of combinations of series and parallel circuits, from simple ones like these to the most complex computers.

If you connected two lamps in parallel then if one is broken, the other would still work. Most of the lamps in your house are wired like this; if a bulb is broken on one lamp then the other lamps are not affected.

Batteries can also be placed in parallel. Placing two batteries in parallel allows them to last longer, or to supply more current at the same time.

Think of each battery as a storage tank that supplies water. If you put two in parallel, you can get more water (current), but the pressure (voltage) stays the same.

For all of the Snap Circuits® projects, the parts may be arranged in different ways without changing the circuit. The order of parts connected in series or in parallel does not matter - what matters is how combinations of these sub-circuits are arranged together. For example, in activity 1 you may swap the locations of the switch and lamp without affecting the circuit operation in any way because they are connected in series.

The choice of whether to use a series or parallel configuration in a circuit depends on the application, but will usually be obvious. For example the overhead lights in the rooms of your home are all connected in parallel so that you can have light on in some rooms and off in others, but within each room the light and switch are connected in series so the switch can control the light.

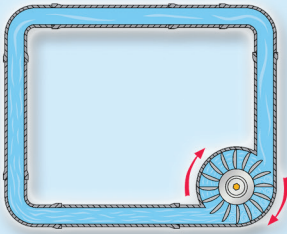
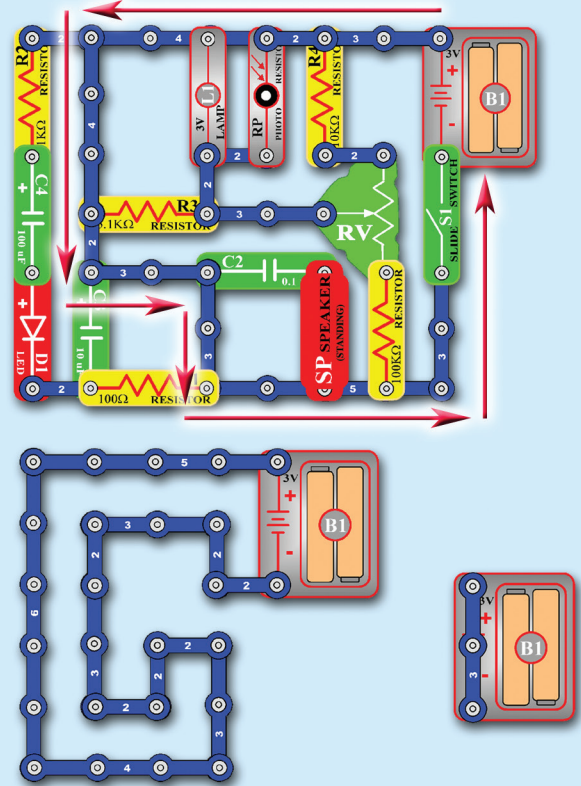
1 - 8 SHORT CIRCUITS

Every circuit will include a power source (the batteries), a resistance (which might be a resistor, lamp, motor, integrated circuit, etc.), and wiring paths between them and back. When wires from different parts of a circuit connect accidentally then we have a “**short circuit**”. You’ve probably heard this term in the movies; it usually means trouble.

A short circuit is a wiring path that bypasses the circuit resistance, creating a **no-resistance path across the batteries**. This will damage components and/or quickly drain your batteries. Be careful not to make short circuits when building your circuits. Always check your wiring before turning on a circuit.

The name “short circuit” refers to how the current through the circuit bypasses (jumps around) other components in the circuit. It is the “easiest” path through the circuit, it is not always the “shortest”.

Here are some examples:



In a short circuit, there is nothing to limit the current in a circuit. However the chemical reaction in a battery cannot supply unlimited current, so the battery voltage drops to zero volts. This is called “overloading” the batteries. This overload produces heat and damages the batteries. Think of this as a pump pumping water in a loop as fast as it can until it burns out.

1 - 9 SOLDER

Solder is used to make electrical connections to components on a printed circuit board. It is a special metal made mostly of tin that melts at relatively low temperature (about 500°F). Solder is applied and melted around a joint where a connection is being made; it creates a solid bond between the metals.

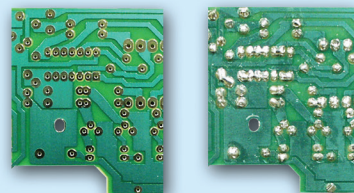
The placement of parts onto circuit boards and the application of solder to connect and hold them in place are usually done automatically with special machines. In fact, the microprocessors used in modern computers are so finely designed that they are almost impossible to solder by hand.



Soldering Iron



Solder



Before Soldering

After Soldering



Soldering Machine

SUMMARY

Summary of Chapter 1:

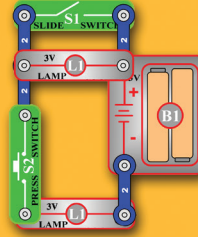
1. The electric current is a measure of how much electricity is flowing in a wire, and is expressed in Amperes.
2. The voltage is a measure of the electric pressure exerted into a wire or circuit by a battery or other power source, and is expressed in volts.
3. Switches are used to turn on or turn off the flow of electricity in a circuit.
4. A light bulb converts electricity into light.
5. Most electronic products have components mounted on circuit boards with the wires literally printed on the board surface.
6. Electrical circuits are all combinations of series and parallel configurations.
7. A short circuit is a no-resistance path across a power source, and causes damage to components and batteries.
8. Solder is a special metal that is melted to make solid electrical connections.

QUIZ

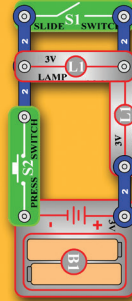
Chapter 1 Practice Problems

1. The flow of electricity is measured in _____.
A. gallons B. minutes C. amperes D. volts
2. To turn on a switch, you _____ it.
A. voltage B. open C. pressurize D. close
3. Three of the choices below are the same circuit with the parts arranged in different ways. Which choice is a different circuit?

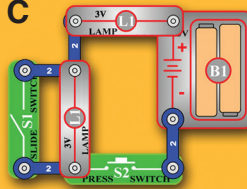
A



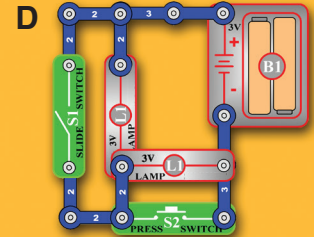
B



C

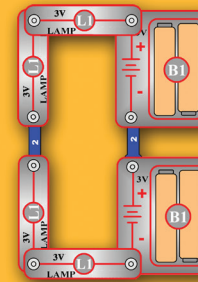


D

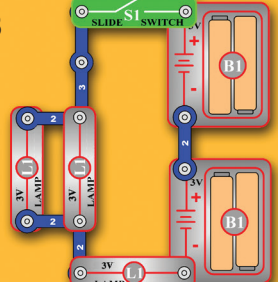


4. Which of these is a short circuit?

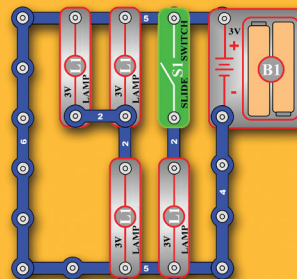
A



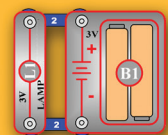
B



C



D



Answers: 1. C, 2. D, 3. D, 4. C

CHAPTER 2: MOTORS & ELECTRICITY

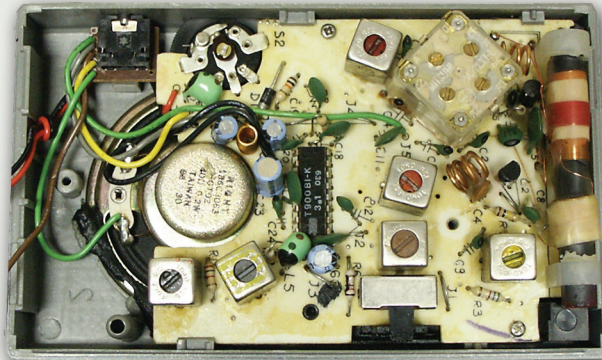
In this chapter you will learn about generators and motors. A generator uses mechanical motion to create electricity and a motor uses electricity to create mechanical motion. This statement may not seem important to you but it is actually the foundation of our present society. Nearly all of the electricity used in our world is produced at enormous generators driven by steam or water

pressure. Wires are used to efficiently transport this energy to homes and businesses where it is used. Motors convert the electricity back into mechanical form to drive machinery and appliances. **The most important aspect of electricity in our society - more important than the benefits of the Internet - is that it allows energy to be easily transported over distances.**



Note that “distances” includes not just large distances but also tiny distances. Try to imagine a plumbing structure of the same complexity as the circuitry inside a portable radio - it would have to be

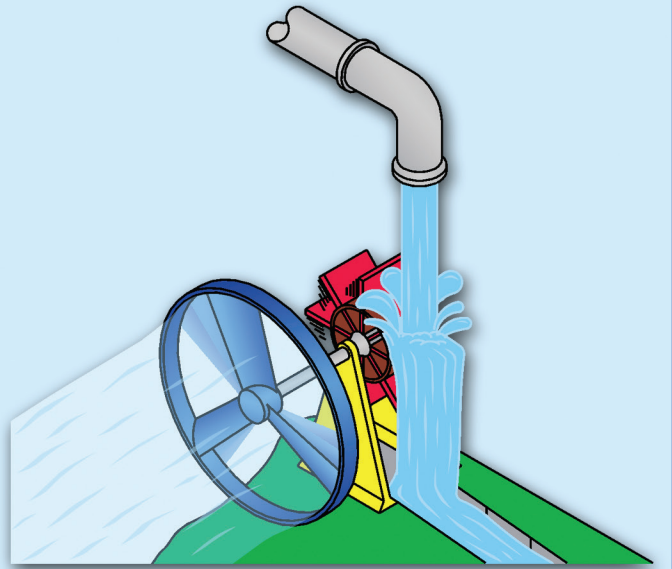
large because we can't make water pipes so small. Electricity allows complex designs to be made very small.



2 - 1 MOTORS

Water flowing under pressure in a pipe or a fast-moving stream can be used to turn a paddlewheel. If the paddlewheel was linked to a fan blade then you could use the water pressure to turn the fan, perhaps to cool yourself on a hot day. If the water was flowing very fast due to high pressure, then you could get the fan moving fast enough it might create a strong airflow like a propeller on a plane.

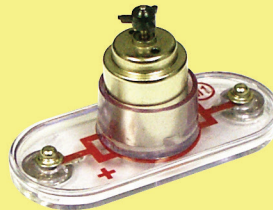
A similar thing happens in a motor, with electricity instead of water. A motor converts electricity into mechanical motion.



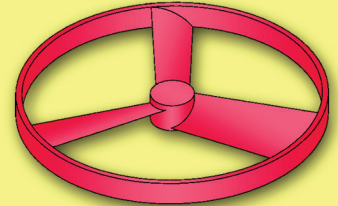
INTRODUCING NEW PARTS

Snap Circuits® includes one motor, shown here with its symbol. Snap Circuits® also includes a fan, which is used with the motor. An electric current in the motor will turn the shaft and the motor blades, and the fan blade if it is on the motor.

Motor Symbol

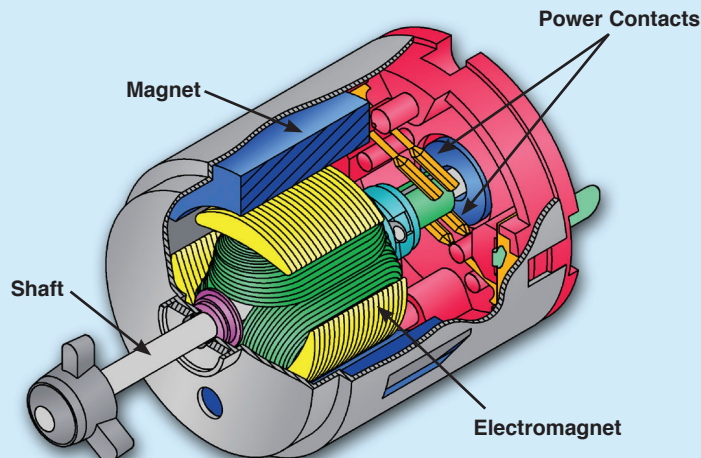


Motor (M1)



Fan Blade

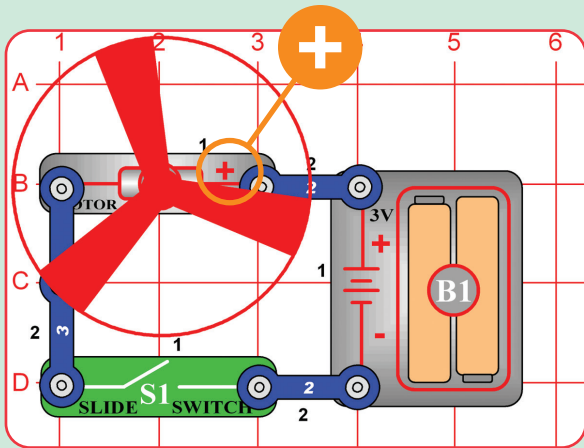
How does electricity turn the shaft in the motor? The answer is magnetism. Electricity is closely related to magnetism, and an electric current flowing in a wire has a magnetic field similar to that of a very, very tiny magnet. Inside the motor is a coil of wire with many loops, if a large electric current flows through the loops the magnetic effects become concentrated enough to move a small magnet. The motor also has a small magnet, on a shaft. When electricity moves the magnet, the shaft spins. If the fan is on the motor shaft then its blades will create airflow.



ACTIVITY 5 Motor and Switch

Use the circuit diagram symbols to draw the circuit shown below.

Circuit Diagram



Build the circuit pictured on the left by placing all parts with a black 1 next to them on the board first. Then assemble the parts with a black 2. Place the motor (M1) with the “+” side as shown.

What happens when you close the switch? _____

What happens when you open the switch? _____

What is the electrical energy changed into? _____

How is this circuit similar to the lamp circuit in Activity 1? _____

Think of several examples of tools or toys powered by a motor. _____

WARNING: Moving parts. Do not touch the fan or motor during operation. Do not lean over the motor

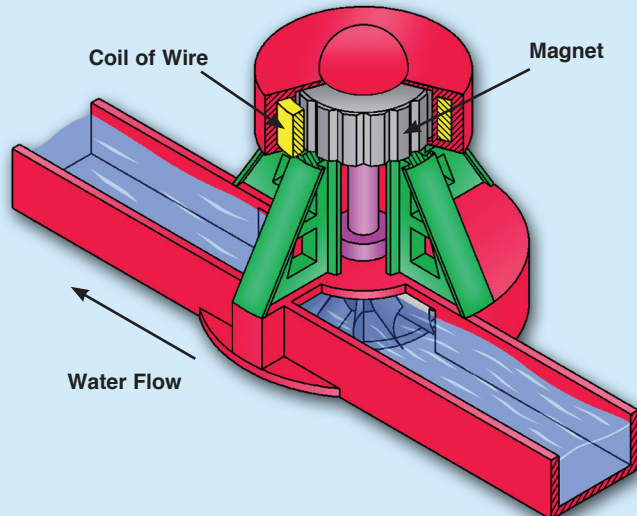
Motors are used in all electric powered equipment requiring rotary motion, such as a cordless drill, electric toothbrush, and toy trains. An electric motor is much easier to control than gas or diesel engines.

The electromagnetic effect described above also works in reverse - spinning a magnet next to a coil of wire will produce an electric current in that wire. This is what happens in a **generator**, which uses mechanical motion to create electricity. In an electric power plant, high-pressure water (from a dam) or steam (heated by burning oil or coal) is used to spin a paddlewheel linked to magnets. The magnets create an electric current in a coil of wire, which is used to power our cities.

In theory, you could connect your Snap Circuits® motor directly to the 3V lamp and spin the fan blade with your fingers to light the lamp. In reality, it would be impossible for you to spin the motor fast enough to produce enough current to get

even a glimmer of light from the lamp.

To summarize, **a generator uses mechanical motion to create electricity and a motor uses electricity to create mechanical motion.**

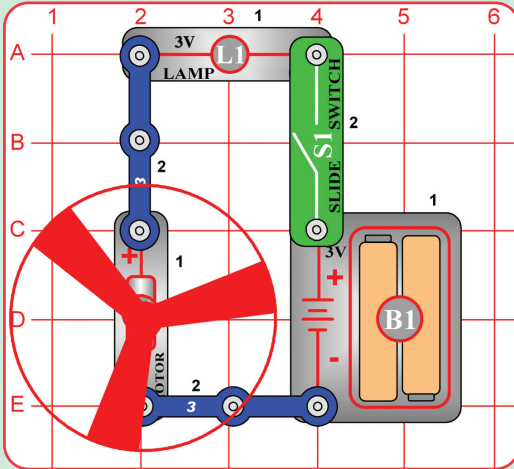


2 - 2 MOTOR CIRCUITS

ACTIVITY 6 Lamp and Fan in Series

Use the circuit diagram symbols to draw the circuit shown below.

Circuit Diagram



Build the circuit pictured on the left. Place all the parts with the black 1 next to them on the board first, then the parts with the black 2.

What happens when you close the switch? _____

What happens when you open the switch? _____

Open the switch. Take the fan off the motor. Close the switch. Describe What happens. _____

The circuits in Activity 1, 2, and 3 were series circuits. In a series circuit all of the parts are placed on the board one after the other.

WARNING: Moving parts. Do not touch the fan or motor during operation. Do not lean over the motor

If the switch is on, the lamp will light and the fan will spin. If the lamp or the motor is broken then neither will work, because they are in series.

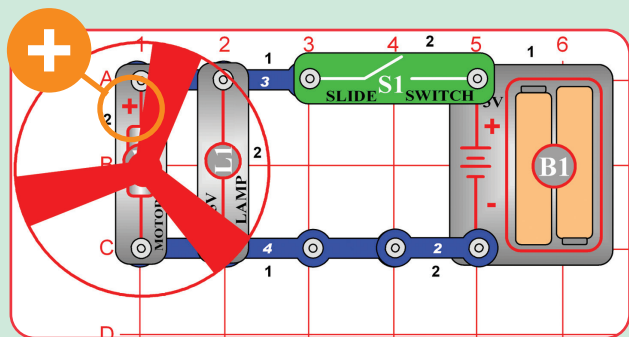
Since the lamp and motor are in series, the voltage from the batteries will get divided between them. The voltage at the motor is reduced, so the motor speed will be reduced.

If the fan was not on the motor then the motor would spin much faster but the lamp would not be as bright. The motor needs more voltage to spin faster, so there is less voltage available to light the lamp.

ACTIVITY 7 Lamp and Fan in Parallel

Use the circuit diagram symbols to draw the circuit shown below.

Circuit Diagram



What happens when you close the switch? _____

What happens when you open the switch? _____

Remove the lamp. What happens to the motor? _____

Install the lamp again. Open the switch. Remove the fan blade from the motor. Close the switch. What happens to the lamp? _____

How is a parallel circuit different from a series circuit?

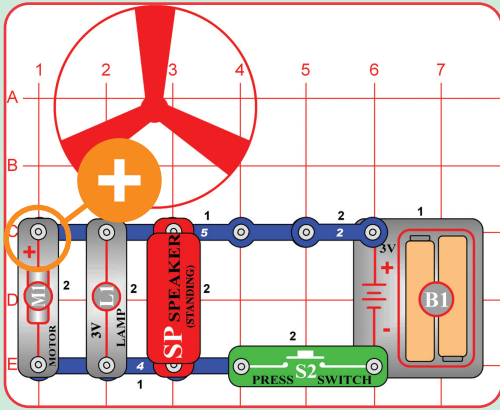


WARNING: Moving parts. Do not touch the fan or motor during operation. Do not lean over the motor

If the switch is on, the lamp will light and the fan will spin. If the lamp or the motor is broken then the other will still work, because they are connected in parallel. Since the lamp and motor are in parallel,

the full voltage from the batteries would be applied to both. So the fan would spin faster than for the circuit in Activity 3, which divided the battery voltage between the lamp and motor.

ACTIVITY 8 Lamp, Speaker, and Fan in Parallel



What happens when you press the switch S2? _____

Circle the number of paths that exist for the electric current to follow? 1 2 3 4 5 6

Put the fan on the motor when the motor stops spinning. Press the switch. What changes do you notice? _____

What is the purpose of the speaker in the circuit? _____

Remove the speaker from the circuit. What changes do you notice? _____

Remove the lamp. Press the switch. What effect does this have on the motor? _____

Don't leave the circuit on too long or it will drain the batteries.

Do you think the lights in your home are wired in series or parallel? _____

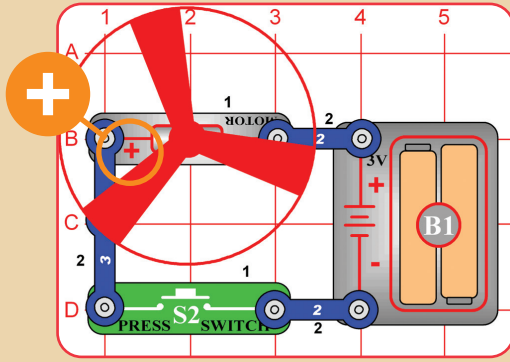
In this circuit the lamp will not be at full brightness, even though the full battery voltage is applied to it. Because as the circuit current increases, the voltage produced by a battery is reduced. The motor draws a high current, very high when it first starts up with the fan on. The chemical reaction in the batteries can't supply such a high current, so the battery voltage (electrical pressure) drops.

If your household has a meter to measure voltage, use it to measure the battery voltage with the slide switch on and off. You would see the voltage drop when the switch is on. Take the fan off the motor and push the switch again. The lamp will be brighter now. It doesn't take as much current to spin the motor without the fan, so the battery voltage doesn't drop much.

The AA batteries used to power your snap circuits have + and - markings, called **polarity** markings. The chemical reaction in the batteries only makes the electric current flow in one direction. To make the current flow in the other direction reverse the batteries (all batteries in the same circuit must be reversed). The motor also has + and - markings, because if the direction of current flow through is

reversed than the motor will spin in the opposite direction (reversing the electric current reverses the magnetic field generated, which reverses the direction the shaft spins). The lamp, switch, and wires have no + and - markings on them because they work the same regardless of which way the current is flowing.

ACTIVITY 9 Flying Saucer



Build the circuit as shown. Place the motor (M1) with the “+” side on the left.

Close the slide switch. Allow the motor to run until it reaches maximum speed, then open the slide switch to turn off the current. Be careful not to look directly down on the fan when it is spinning.

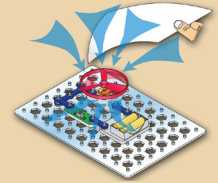
What happens and why? _____

Note: The polarity of the motor is reversed. The positive terminal of the battery is connected to the negative terminal of the motor.

WARNING: Moving parts. Do not touch the fan or motor during operation. Do not lean over the motor.

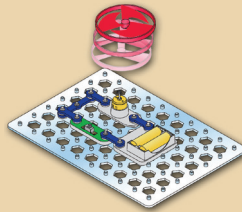
If the switch is turned off when the motor is spinning at full speed, the fan will rise into the air. Be careful not to touch the motor or fan while it is spinning at high speed. In this circuit the fan blades suck in air and push it down to the table.

If you hold a sheet of paper above the fan, you will see it get sucked toward the fan.



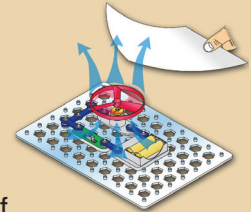
How does the fan rise? Think first about how you swim. When your arms or legs push water behind you, your body moves ahead. A similar effect occurs in a helicopter - the spinning blades push air down, and create an upward force on the blades. If the blades are spinning fast enough, the upward force will be strong enough to lift the helicopter off the ground.

While the switch is on, the motor rotation locks the fan on the motor shaft. The fan does not spin fast enough to lift the entire circuit off the ground. Sometimes there may be enough lift to make the

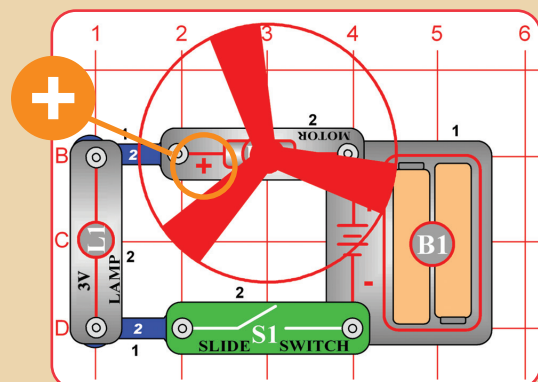


base grid hover around the table like a puck on an air hockey table. When the motor is turned off, the fan unlocks from the shaft. The fan rises into the air like a helicopter, since it is no longer held down by the weight of the full circuit.

If the motor polarity were reversed (+ on the right), the fan would never fly. The fan blades are sucking in air around the motor and pushing it straight up. If you hold a sheet of paper above the fan, you will see it get pushed up and away from the fan.



ACTIVITY 10 Decreasing Lift



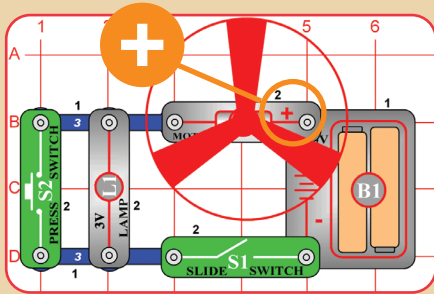
What does the lamp do to the motor in the circuit? _____

When the motor has reached maximum speed, slide the switch off. What happens? _____

Is this a series circuit or parallel circuit? _____

Build the circuit and slide the switch (S1) to on. Compare this circuit to activity 9.

ACTIVITY 11 Two-Speed Fan



What is the path of the current through this circuit when only the slide switch is closed? _____

What happens when you close the press switch? _____

Is this a series or parallel circuit? _____

What is the purpose of the lamp in this circuit? _____

If you have a multiple speed fan at home, how can you increase or decrease the speed? _____

2 - 3 FUSES

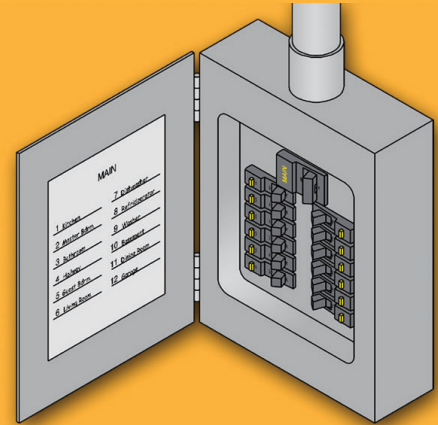
Occasionally electronic products/components break due to people using them incorrectly, accidents, natural storms, bad design, or component failures. Often the problem is a short circuit, which results in an excessively high current flow. This high current can overheat components in the product enough to damage them, make them explode, or start a fire.

A **fuse** is usually a special wire that breaks (“blows”) when too much current flows through it. A “blown fuse” shuts down the product before anything can overheat or cause a fire. Although a “**blown fuse**” prevents the product from working, fuses are easy to replace.

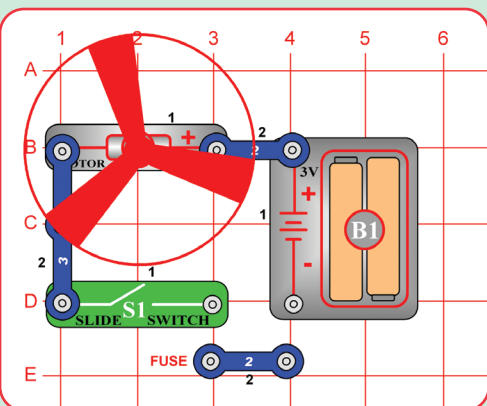
Fuses are very important and most electronic products have one. Products using electricity supplied by the electric company are usually required to have them because the high voltages and currents available here can cause severe damage and fires. Small battery-powered products

usually do not have fuses because the batteries in them are not powerful enough to cause harm.

While many fuses must be replaced when blown, flipping a switch can reset some types. Every home has an electrical box of such fuses, to isolate any problems in one room from the rest of the house and your neighbors. But these fuses protecting your home take a much higher current to “blow” them than a fuse used in a radio.



ACTIVITY 12 Motor and Switch



Imagine that the lower 2-snap wire in the Activity 3 circuit is a fuse:

If the circuit is operating properly then the “fuse” acts as a 2-snap wire. However if the motor breaks and suddenly becomes a short circuit while both switches are on, then there will be nothing to limit the current in the circuit. A very high current will flow from the batteries, and would damage them if it continues. This excessively high current will “blow” the fuse, creating an open circuit just like turning off the slide switch would do. This will protect the batteries from damage. The motor can then be repaired and the fuse replaced.

WARNING: Moving parts. Do not touch the fan or motor during operation. Do not lean over the motor.

2 - 4 YOUR ELECTRIC COMPANY

Batteries are widely used because they are easy-to-use, safe, and portable. For example, Snap Circuits® can be used on a camping trip in a remote wilderness as long as you have batteries. You can even take along spare batteries because they are small and easy to carry.

What if you wanted to take a microwave oven on the camping trip? A microwave oven uses a lot of electricity, so the batteries for it would be large, heavy, expensive, and wouldn't last long. Heavy, high-power products like microwave ovens are not moved often.

Only a tiny portion of the electricity used in our world comes from batteries. The rest is produced at enormous electric power plants, operated by your local electric company. The electricity from these power plants is available at the electrical outlets in the walls of your home. The cost of electricity from the electric company is much less than the cost of electricity from batteries.

The voltage of the electricity supplied by the electric company is 120V, much higher than the voltage of the batteries in Snap Circuits®. This is available at each of the electrical outlets in your home. The current available is very large, since it must power products like dishwashers and TVs.

A “**blackout**” occurs when part of a city is cut off from the power plants supplying it with electricity. The city will appear “black” from the air at night, since there are no electric lights on. This is usually

due to accidents or storms, but is also done to confuse attacking bombers in war.

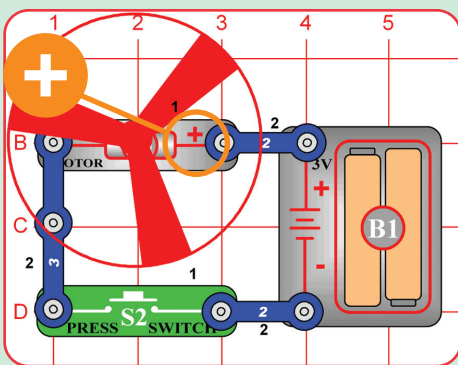
A “**brownout**” occurs when power plants cannot supply enough current to a city during high demand, and must reduce the voltage below 120V. This sometimes occurs on hot days in summer when everyone is using their air conditioners.

Our lives are much easier and more fun by having such power available by simply plugging into an electrical outlet. This amount of electricity is also very dangerous, and it will kill anyone who abuses it. While accidents involving electricity are rare, they kill people every year. **Never put anything into an electrical outlet except an electrical plug.** Battery-powered products are safe, since small batteries are too weak to hurt people.

The protective plastic around the wires to plug in a lamp are all that protects you from the full power of electricity. Damaged electrical cords should always be unplugged and repaired. Remember that electricity travels through water, so don't use electric products while taking a bath (battery-powered products are fine).

Your home has fuses that automatically turn off the electricity in your home if there is an electrical problem, such as a short circuit. These fuses prevent electrical problems in your home from affecting your neighbors, but they do not protect you.

ACTIVITY 13 Spinning Rings



Describe what you see when the press switch is pushed. _____

Is this a series or parallel circuit? _____



Cut out the disc from page 67. Using Scotch tape, attach the disc to the fan blade with the printed side up. Place the fan blade and disc on the motor.

ACTIVITY 14 Strobe the House Lights

Use the circuit from activity 13. Place the circuit under a normal house light. Start the disc spinning and release the press switch. What do you notice happening with the disc? _____

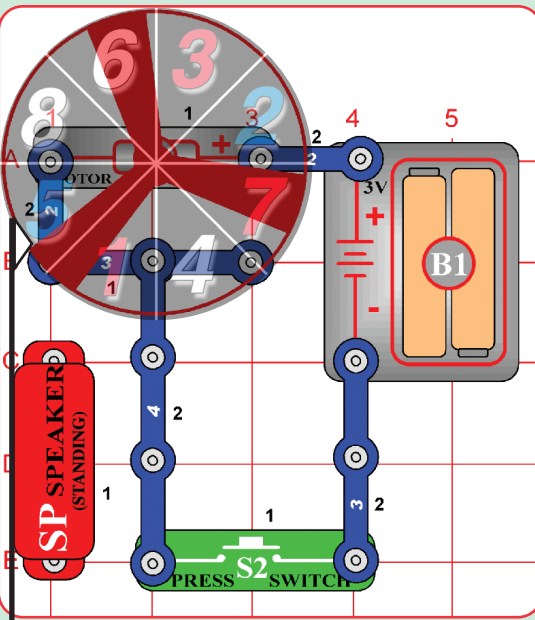
Now, turn off the lights and shine a flashlight on the spinning disc. Release the press switch. How does the disc look under flashlight light? _____

Normal house lights blink at a rate of 30 times a second. How is this different from the flashlight? _____

Place this circuit under a white fluorescent light in your home (don't use an incandescent lamp or LED light). As the speed changes you will notice the white lines first seem to move in one direction then they start moving in another direction. Do you know why it does this? The reason is because the lights are blinking 60 times a second and the changing speed of the motor is acting like a strobe light to catch the motion at certain speeds. To prove this, go into a dark room and try the same test with a flashlight. The light from a flashlight is constant, so you won't see this effect and will always see the lines move in the same direction. The fluorescent lights are blinking because they use the AC power from the electric company. A flashlight uses DC power from batteries.

Note: Some new fluorescent lights use an electronic ballast and they also produce a constant light.

ACTIVITY 15 Math Game



Cut the math disc and paper pointer from page 67. Attach the math disc to the fan blade. Bend and attach the pointer to the speaker so it sticks up over the math disc as shown above.

Each player uses a pencil and paper to keep score on a sheet of paper or note pad. Start with all of the players at zero score.

Each player gets a turn to press the switch, which will cause the disc to spin. Release the press switch. When the disc stops turning the paper pointer will be pointing to a wedge with a number on it. In each game below first player to reach or exceed 100 wins.

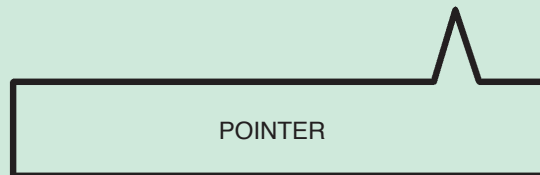
SIMPLE MATH: Add number to your score and the turn moves to the next player.

EASY MATH: Add white and blue numbers to your score but subtract red numbers from your score. Turn ends.

MIDDLE MATH: Add white, subtract red, multiply score by blue. Turn ends.

ADVANCED MATH: Add white, multiply by red, divide score by blue. Only keep two decimal places.

If the pointer is pointing to a line instead of a wedge of color, add 9 to your score and spin again.



PTR

2 - 5 STATIC ELECTRICITY

You may have noticed that sometimes you can get an electric “zap” in your home or school, how clothes stick together when you take them out of the dryer, or when taking off a wool sweater on a dry day. Occasionally differences in electrical charge build up between things, called static electricity. The things, which might include your body, are storing electrical charge. They might store a very small amount of electrical charge at high voltage. This is just like a cloud storing electrical charge before a thunderstorm.

The name “static” is used to describe the electrical charge build-up because the charge

is not moving around to disperse. “Static cling” refers to how clothes sometimes cling to each other in the dryer, due to static electricity. Static electricity in the atmosphere causes the “static” (erratic noises) you hear on your AM radio when reception is poor.

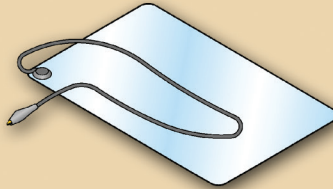
Static “zaps” occur when an electrical current flows to equalize the charge difference. Though the voltage might be high, the current is small and the duration is short. The actual “zap” occurs because the voltage is high enough to “jump” across a high-resistance material (usually air), making a small spark as it happens.

Though the “zap” might sting you briefly, these effects do not harm people. However, these static zaps can damage some types of sensitive electronic components and electronics

manufacturers have to protect against it. Such protection includes static wrist straps, conductive floor matting, and humidity control. The parts in Snap Circuits® will not be damaged by static.



Anti-Static Wrist Strap



Anti-Static Floor Mat



Anti-Static Ankle Strap



In the same way, clouds can build up a static electrical charge. This charge might become very large, and it is spread out over the enormous volume of the clouds. Lightning occurs when this electrical charge discharges into the ground, and can be very destructive. Lightning is looking for the lowest-resistance path from the clouds to the ground.

Do you know why you often “see” lightning before you “hear” it? It is because light travels faster than sound.

Since people have less resistance than air, standing in an open field during a thunderstorm is very dangerous. Houses and other buildings have “**lightning rods**” to protect them, which are metal bars from the roof into the ground. Their purpose is to encourage lightning to go through the rods to the ground, instead of going through the house to the ground.

Large aircraft can build up a large electrical charge during a long flight. A wire similar to a lightning rod is usually connected to an aircraft shortly after landing, as a precaution against static zap.

Static Electricity Example:

Comb your hair vigorously with a plastic comb and hold the comb near some little (1cm x 1cm) scraps of paper to pick them up OR tilt the comb near a slow, steady stream of water from a faucet and see how the water bends towards it.

QUICK QUIZ

1. List all the products in your home that use an electric motor.
2. Name some examples of static electricity.

2 - 6 TYPES OF LAMPS

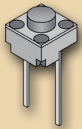
The lamps in Snap Circuits® are **incandescent** type, the same as the larger lamps in your home. The bulbs contain a special high-resistance wire, called the **filament**. When an electric current passes through it the wire gets so hot that it glows. Heat is also produced, and the glass bulb prevents the filament from reacting with oxygen in the air and burning. When the voltage rating of an incandescent bulb is exceeded, the filament gets so hot it burns out. Filaments are usually made of tungsten, since ordinary copper would melt.

The **fluorescent** light bulbs that come in white 4 ft. tubes are the standard room lights for offices and schools. They pass electric current through a gas, usually neon. This gas emits light as the electricity

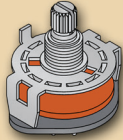
passes through it, similar to how a tungsten wire does. Although larger and more expensive than ordinary incandescent lamps, they are more efficient at converting electricity into light.

The difference in heat produced between incandescent and fluorescent light bulbs might surprise you. Find a fluorescent bulb and feel the heat coming off it; you won't feel much. Find an incandescent lamp THAT HAS BEEN OFF FOR A WHILE and turn it on. Feel the heat it produces; it soon becomes too hot to touch. Only about 5% of the electricity used by incandescent bulbs is converted into light. Without the more efficient fluorescent bulbs, our society of office buildings might have been much different.

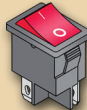
2 - 7 TYPES OF SWITCHES



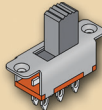
Push Button



Rotary



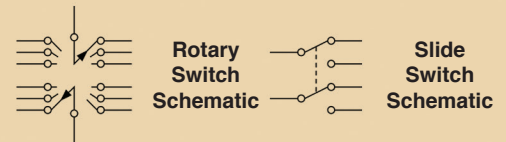
Rocker



Slide

The slide and press switches included in Snap Circuits® are simple switches, more complex types are also available. Switches come in almost every shape and size imaginable. There are membrane, rocker, rotary, DIP, locking, and non-locking types just to name a few.

Very often, a single switch is used to make many different connections. The combinations of connections for a switch are indicated in the symbol for it. Here are some examples:



2 - 8 ELECTRICIANS

There are many different ways of using electricity, so there are many types of people who work directly with it. The main categories are electricians and engineers/technicians. Although many people think of these as being the same career, they are actually very different. They attend different schools, use different tools, and work in different places.

Electricians are the people who install electrical wiring into homes and businesses. Electricians deliver the electricity to your home to be used. It takes a lot more electricity to operate everything in a building than to operate a computer or radio, so safety is very important and the equipment they use can handle high levels of voltage and current. Buildings are not easy to re-wire, so the wiring must be reliable and safe for many

years. Electricians are trained in union and trade schools. Local government licenses them because buildings must be wired as per strict local building codes to be sure they will be safe even after many years.

Electrical/electronics engineers and technicians design and develop products that will use the electricity that electricians have brought to them. Voltages and currents are much lower and safer, but circuits can be much more complex (like computers) and technologies change quickly. Electronic products are mass-produced in factories, unlike building wiring which must be installed in the building. Engineers are trained in colleges and technicians are trained in trade schools. Government does not regulate them but products must meet industry safety standards.

SUMMARY

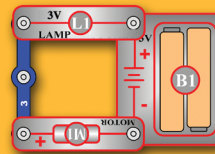
Summary of Chapter 2:

1. An electric current flowing in a wire has a magnetic field.
2. A generator uses mechanical motion to create electricity and a motor uses electricity to create mechanical motion.
3. A fuse is a special wire that breaks when an excessively high current flows through it, used for safety.
4. Electrical outlets are 120V, and can supply enough current to kill people.
5. An electrical current that is changing is called an alternating current (AC). An electrical signal that is constant and unchanging is called a direct current (DC). The electricity in homes is AC power.
6. Static electricity can cause clothes to stick together. Lightning occurs when static electricity in clouds discharges into the ground.
7. Only a small amount of the electricity used by light bulbs is converted into light, the rest becomes heat.

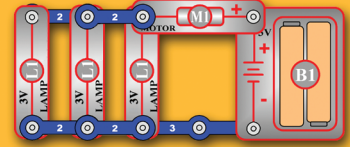
QUIZ

Chapter 2 Practice Problems

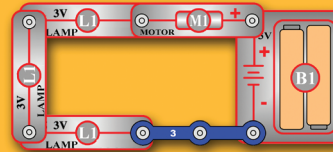
1. Fuses are needed for all of the following reasons except:
 - A. They improve circuit performance.
 - B. To prevent an electrical problem from starting a fire.
 - C. To limit the current in a circuit.
 - D. People don't always use products correctly.
2. All of the following are caused by static electricity except:
 - A. Lightning
 - B. Erratic noises interrupting music on your AM radio.
 - C. Clothes sticking together in the dryer.
 - D. Blackouts
3. Which circuit will spin the fan the fastest? Which will spin fan the slowest?



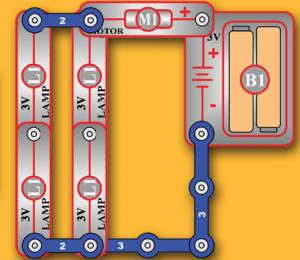
A



B

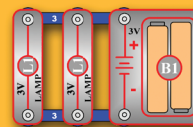


C

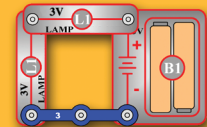


D

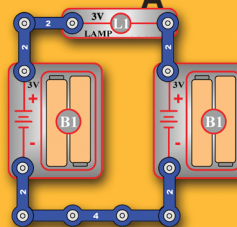
4. Which circuit will make the lamp the brightest?



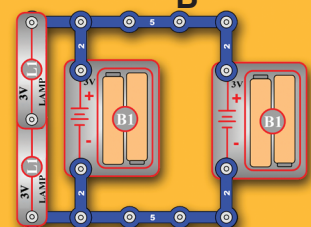
A



B



C



D

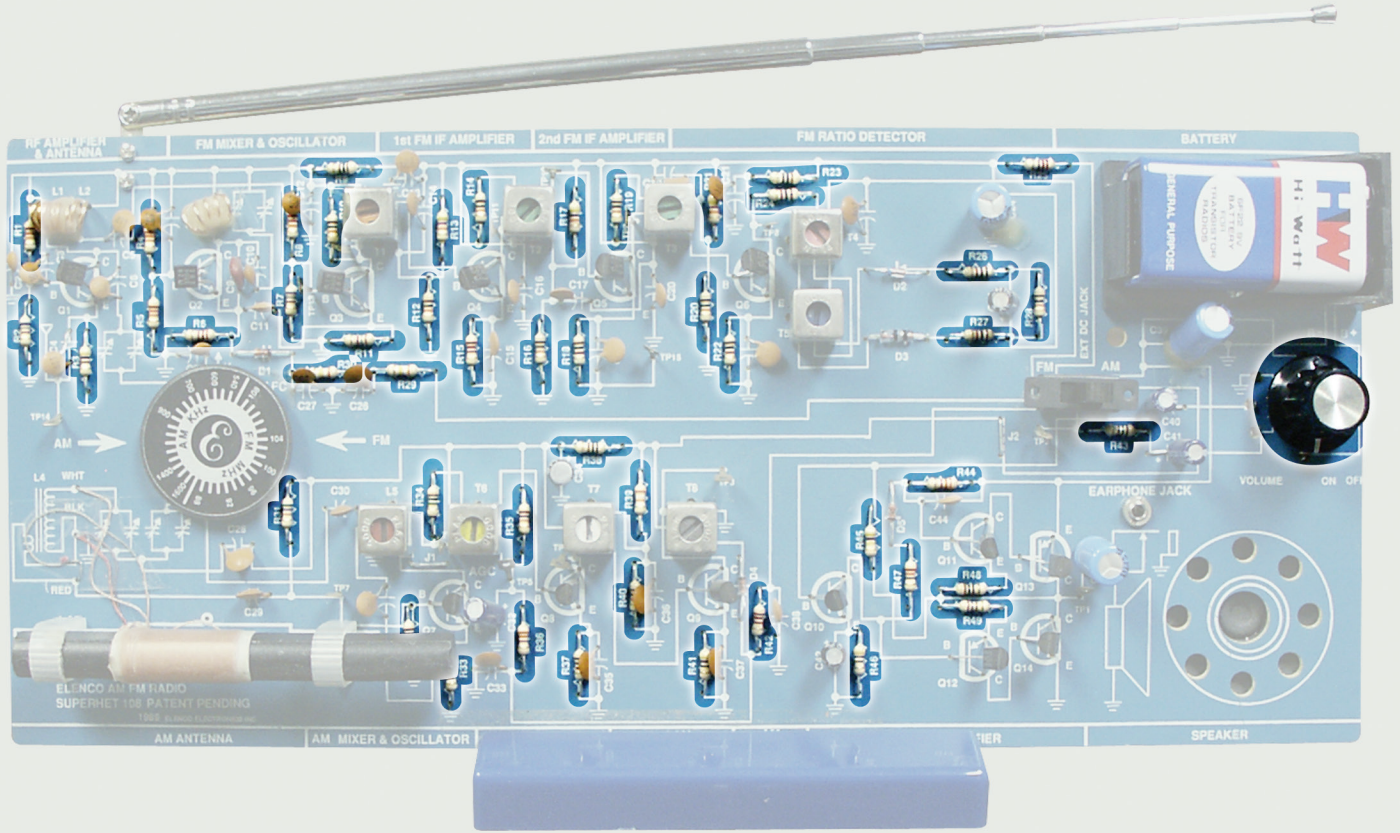
Answers: 1. A, 2. D, 3. B/C, 4. A

Chapter 3: Resistance & Electronic Sound

All of the circuits and components studied in chapters 1 and 2 are commonly used by electricians, though the actual parts used will be for much higher voltages and currents than the Snap Circuits® parts representing them. Electricians are concerned with getting the electricity to where it will be used as efficiently as possible, without wasting energy.

In consumer products like toys, radios, and computers, electronics engineers and technicians want to control how it is used.

In this chapter you will learn about resistors, which are used to limit and control the flow of electricity. As an example of how important resistors are in electronics, consider a typical AM/FM radio:

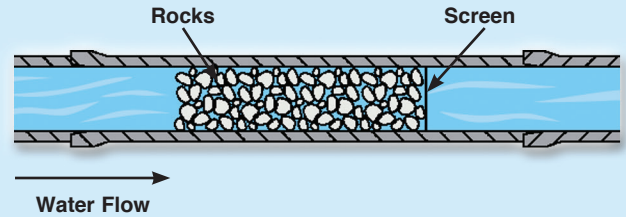


This radio contains 50 resistors, which are highlighted. The radio needs every one to operate properly. Televisions contain hundreds of resistors, and computers contain even more.

3 - 1 RESISTORS

Why is the water pipe that goes to your kitchen faucet smaller than the one that comes into your house from the water company? And why is it much smaller than the main water line that supplies water to your entire town? The reason is that you don't need so much water. The pipe size limits the water flow to what you actually need.

Electricity works in a similar manner, except that wires have so little resistance that they would have to be very, very thin to limit the flow of electricity. They would be hard to handle and break easily. But the water flow through a large pipe could also be limited by filling a section of the pipe with rocks (a thin screen would keep the rocks from falling over), which would slow the flow of water but not stop it.



Resistors are like rocks for electricity, they control or limit how much electric current flows. The resistance, expressed in **ohms** (Ω , named after George Ohm) or kilohms ($k\Omega$, 1000 ohms) is a measure of how much a resistor resists the flow of electricity.

To increase the water flow through a pipe you can increase the water pressure or use less rocks. To increase the electric current in a circuit you can increase the voltage or use a lower value resistor.

INTRODUCING NEW PARTS

Snap Circuits® includes one resistor: 100Ω (R1). If you have the parts with you, take it out and look at it.



The symbol for the resistor is this squiggly line:



Resistor R1

3 - 2 LEDs

The Snap Circuits lamp you have needs a high current to be bright, and can be thought of as high current meters since their brightness is an indication of how much current is flowing in a circuit. Even the smallest resistor included in Snap Circuits® will limit the current such that the lamp would not light at all. So you need a low current meter.

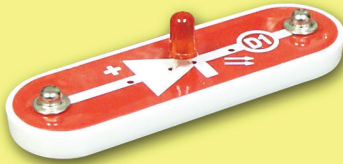
Light Emitting Diodes (LEDs) may be thought of as one-way, low-current meters. Like light

bulbs, their brightness increases as the current through them is increased. But they are made from different materials and so have other characteristics. They are more sensitive than light bulbs and become bright at much smaller currents, but will be damaged by high currents (which is why they should always be used with resistors or other parts to limit the current).

They can be made to produce specific colors of light, usually red, green, or yellow. They also completely block current flow in one direction.

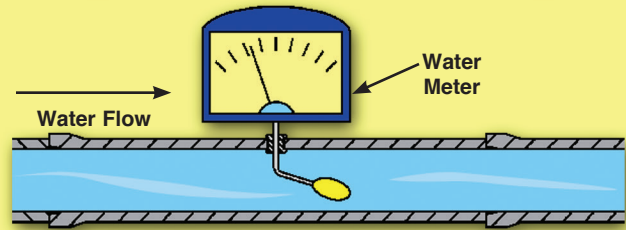
INTRODUCING NEW PARTS

Snap Circuits® includes a red LED. The arrow in the symbol of the part includes which direction it allows current to flow in (referred to as the forward direction):



Red LED (D1)

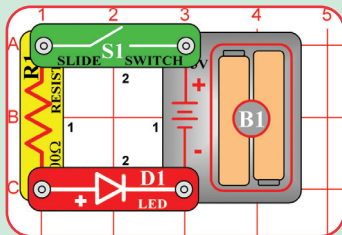
LED Symbol



ACTIVITY 16 Light Emitting Diode

Use the circuit diagram symbols to draw the circuit shown below.

Circuit Diagram



Is this a series or parallel circuit? How do you know? _____

What happens when you close the switch? _____

How is this circuit like the circuit in Activity 1? How is it different? _____

What is the function of the resistor? _____

List several devices you have seen that use LEDs in them. _____

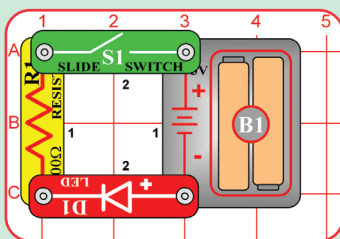
Why are LEDs used instead of a incandescent light bulbs in these devices? _____

If the switch is on, the LED (D1) will light. The resistor limits the current so that the LED is not damaged (never place an LED directly across the battery). The LED is just like a lamp here, except that it would not be as bright and would use less battery power.

Also, an LED appears much brighter when viewed from above than from the side. LEDs concentrate most of their light in one direction, unlike a light bulb which emits light nearly equally in all directions.

If the resistor value in the circuit were increased, the LED would become much dimmer. For example, if the 100Ω resistor (R1) was replaced with a 10KΩ resistor (not included), the LED light could only be seen if the room was very dark.

ACTIVITY 17 One Direction for the LED



Rebuild the circuit used in Activity 16, but put the LED facing in the opposite direction as shown on the left.

What happens when you close the switch? _____

What path is the electric current following? _____

What effect did turning the LED around have on the flow of electric current? _____

3 - 3 THE PHOTO RESISTOR

Some materials, such as Cadmium Sulfide, change their resistance when light shines on them. Electronic parts made with these light-sensitive

materials are called photoresistors. Their resistance decreases as the light becomes brighter.

INTRODUCING NEW PARTS

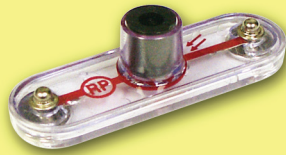
Snap Circuits® includes one photoresistor. Its resistance value changes from nearly infinite in total darkness to about 1k Ω when bright light shines directly on it. Note that a black plastic case partially shields the Cadmium Sulfide part.



Photo Resistor (RP)

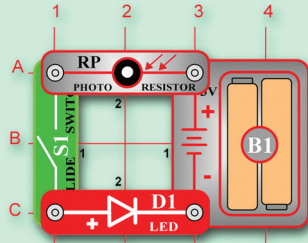


Photo Resistor Symbol



ACTIVITY 18

Consider this mini-circuit:

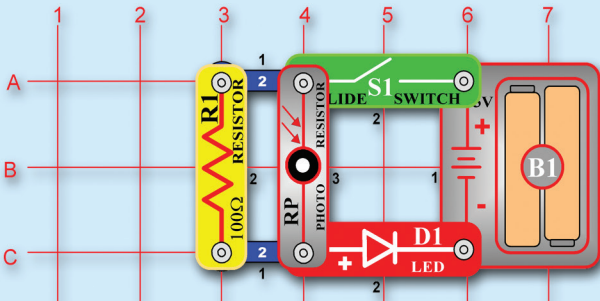
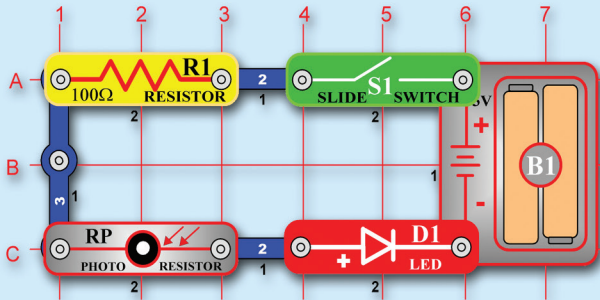


The brightness of the LED depends on how much light shines directly on the photoresistor. If the photoresistor is held next to a flashlight or other bright light, then the LED will light. It may be dim, so wrap your hand around it to see it better.

Photoresistors are used in applications such as street lamps, which come on as it gets dark due to night or a severe storm.

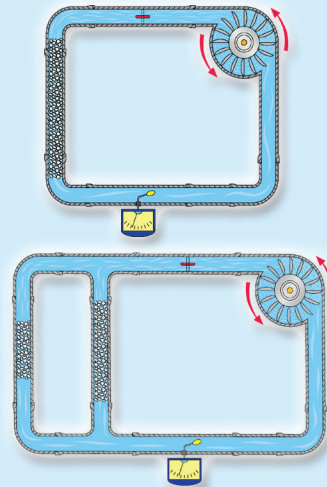
3 - 4 RESISTORS IN SERIES & PARALLEL

Consider these two mini-circuits:



The first circuit has the 100 Ω and 1k Ω resistors in series, the second circuit has them in parallel. Which circuit will make the LED brighter?

Just think of the resistors as rock piles slowing down the flow of water in a pipe:



From the water diagrams, it should be easy to see that the circuit with the resistors in parallel will have the brighter LED. You can build these mini-circuits with your snap circuits parts to prove this.

Placing resistors in series increases the total resistance, and so decreases the current to the LED. Resistors in series add together. **Placing resistors in parallel decreases the total resistance**, and so increases the current to the LED.

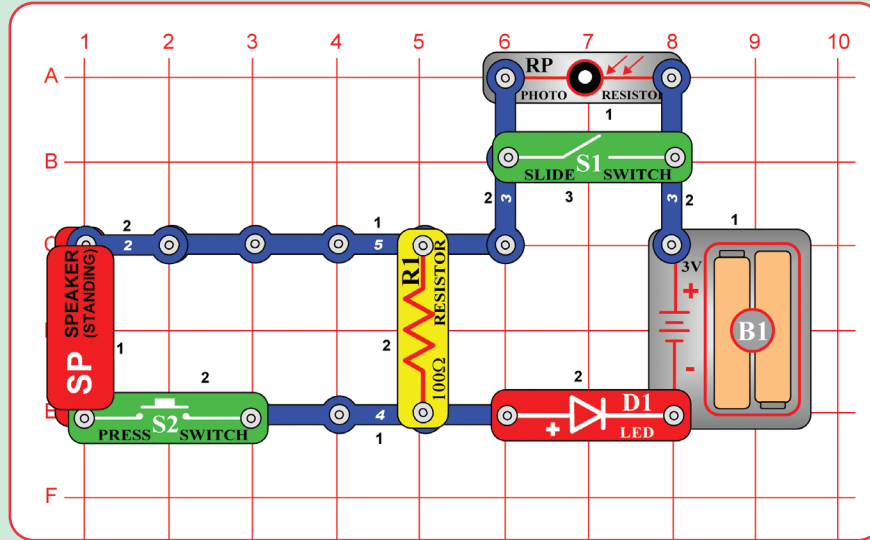
Advanced students can compute the total resistance as follows:

$$R_{\text{series}} = R_1 + R_2 + R_3 + \dots \qquad \frac{1}{R_{\text{parallel}}} = \frac{1}{R_1} + \frac{1}{R_2} + \frac{1}{R_3} + \dots$$

The total series resistance is greater than the biggest resistor, and the total parallel resistance is smaller than the smallest resistor.

ACTIVITY 19

As a review, consider this mini-circuit. The speaker is used here as an 8Ω resistor, its sound-making properties will be discussed later. Make sure there is a bright light shining on the photoresistor (RP).



If the slide switch (S1) is on, then the LED will be on but not very bright as the $5.1k$ resistor limits the current. Turning off the slide switch places the $10k$ resistor in series and the LED becomes very dim. If both switches are on, the $1k$ resistor is in parallel with the $5.1k$ and so the LED becomes very bright.

You've learned that when you increase resistance in a circuit, less current flows (making an LED dimmer). This relationship between voltage, current, and resistance is the most important one in electronics. It is known as **Ohm's Law** (after George Ohm who discovered it in 1828):

$$\text{Current} = \frac{\text{Voltage}}{\text{Resistance}}$$

The most basic rules for analyzing circuits as known as **Kirchhoff's Laws** (known after Gustav Kirchhoff, who stated them in 1847):

1. The total voltages driving a circuit must equal the voltage drops within it.
2. All current flowing into a point must flow out of it.

The "**power**" of electricity is a measure of how much energy is moving through a wire. It is expressed in **Watts** (W, after James Watt for his work with engines). It is a combination of the electrical voltage (pressure) and current:

$$\text{Power} = \text{Voltage} \times \text{Current}$$

OR

$$\text{Power} = \frac{\text{Voltage} \times \text{Voltage}}{\text{Resistance}}$$

3 - 5 RESISTANCE

Just what is Resistance? Take your hands and rub them together very fast. Your hands should feel warm. The friction between your hands converts your effort into heat. **Resistance** is the electrical

friction between an electric current and the material it is flowing through; it is the loss of energy from sub-atomic particles as they move through the material.

You can also compare resistors to the friction with the ground when you walk. If there is too much friction (like two feet of snow) you have to go very

slow or get stuck. If there is too little friction (like ice) then you have no control and will slip and fall.

Resistors are made from carbon and can be constructed with different resistive values, such as the five parts included in Snap Circuits®. If a large amount of current is passed through a resistor then it will become warm due to the electrical friction. Resistors get warm because they exert control by wasting power as heat. Light bulbs use a small piece of a highly resistive material called tungsten. Enough current is passed through this tungsten to heat it until it glows white hot, producing light.

Metal wires have some electrical resistance, but it is very low (less than 1Ω per foot) and can be ignored in almost all circuits. Materials, such as metals, which have low resistance are called **conductors**. The best conductor material known is silver, but it is too expensive to be widely used. Copper is second best, and it is used in most wires and printed circuit boards in the electronics industry.

Electric stoves and heaters use resistors to change electricity into heat.

Materials such as paper, plastic, and air have extremely high values of resistance and are called **insulators**.

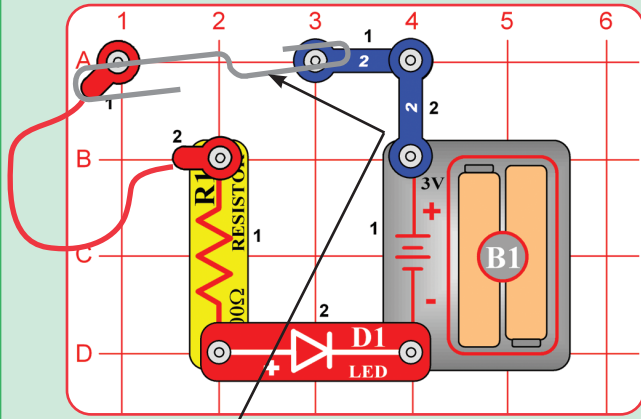
LEDs are made from materials called **semiconductors**, so-called because they have more resistance than metal conductors but less than insulators. Most semiconductors are made of Silicon but Gallium Arsenide is usually used in LEDs. Their key advantage is that their resistance

can be changed by the operating conditions to be very high or very low. Transistors (current amplifiers) are made from semiconductor materials, and are the basic building blocks for computers and memory circuits.

Nearly all electricity produced eventually becomes heat. All currents flowing through resistors produce heat in them. Light from a lamp

or TV produces heat in whatever it shines on. All the circuits in a computer produce heat, and most computers have vents to get this heat out.

ACTIVITY 20 CONDUCTION DETECTOR



Listed below are items that you will place across the terminals 1 at a time to determine if they are conductors (allow electricity to flow) or insulators (prevents the flow of electricity). Use the jumper wire shown to bridge the gap when testing small items such as a penny. First predict which materials are conductors or insulators by filling in the blue column in the table below.

To make sure the circuit is working properly, place a paper clip across the opening between the two 2 snap wires as shown here. The LED should light up. When you place the paper clip across the terminals as shown, current flows from the batteries through the resistor, then the LED, then back to the batteries. The paper clip completes the circuit.

Material	Prediction	Test Result
Clean steel nail	_____	_____
Rusty nail	_____	_____
Piece of chalk	_____	_____
Rubber eraser	_____	_____
Plastic straw	_____	_____
Brass paper fasteners	_____	_____
Copper penny	_____	_____
Aluminum foil strip	_____	_____
Rubber band	_____	_____

Material	Prediction	Test Result
Key	_____	_____
Cardboard strip	_____	_____
Wooden craft stick	_____	_____
Plastic ruler	_____	_____
Metal paperclip	_____	_____
Plastic coated paperclip	_____	_____
String	_____	_____
Pencil lead from a mechanical pencil	_____	_____

Test each item and write the result (conductor or insulator) in the green column.

What do all conductors have in common? _____

List 2 examples of uses for conductors. _____

Which materials are good insulators? _____

List 2 examples of insulators used in everyday life. _____

3 - 6 ELECTRONIC SOUND

INTRODUCING NEW PARTS

Snap Circuits® includes a speaker:

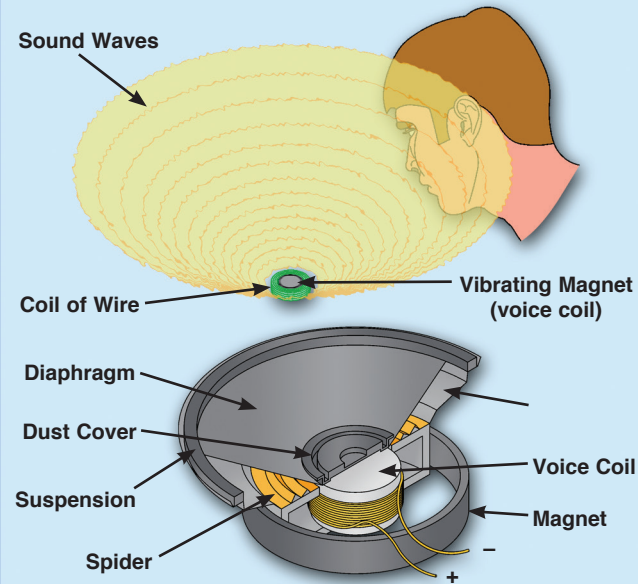


Speaker (SP)



Speaker Symbol

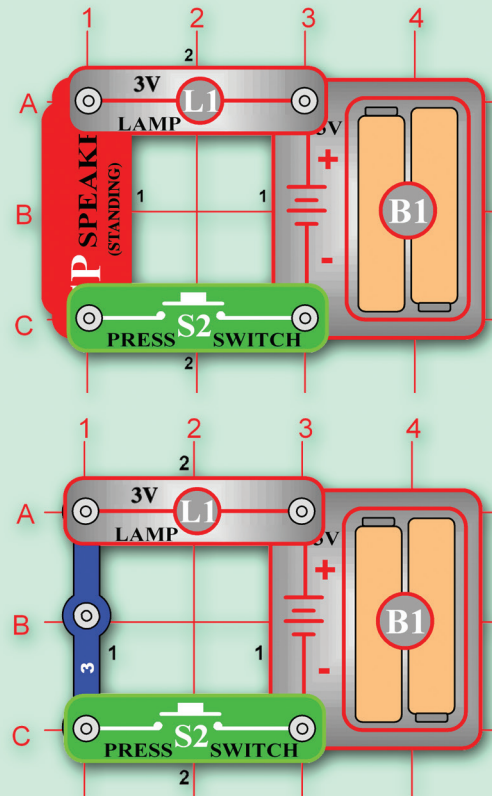
A **speaker** converts electricity into sound. It does this by using the energy of a changing electrical signal to create mechanical vibrations (using a coil and magnet similar to that in the motor). These vibrations create variations in air pressure, called sound waves, which travel across the room. You “hear” sound when your ears feel these air pressure variations.



A speaker can only create sound from a **CHANGING** electrical signal, for unchanging electrical signals it acts like an 8Ω resistor. (An unchanging signal does not cause the magnet in the speaker to move, so no sound waves are created).

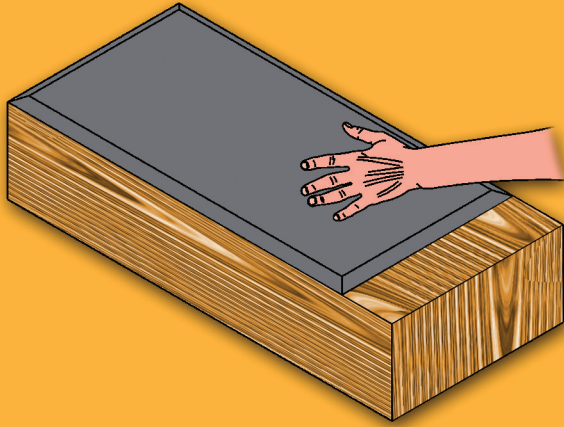
ACTIVITY 21

For example, compare these two mini-circuits:

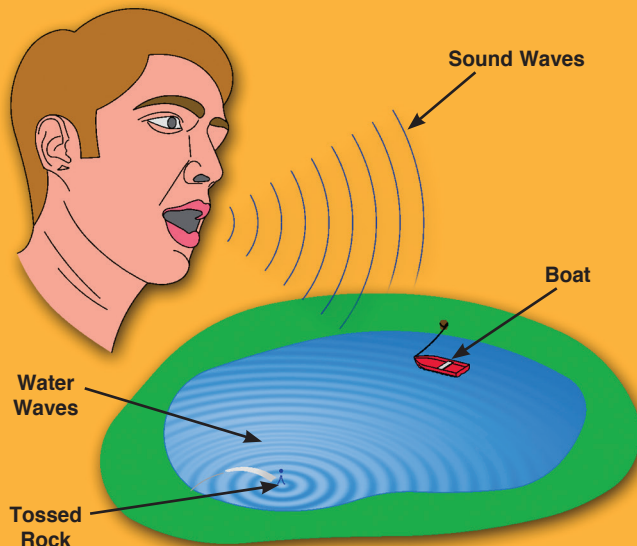


When you press or release the press switch, you hear static from the speaker. When you hold the press switch down, the speaker is silent and the lamp is not as bright as the circuit without it.

What is Sound? **Sound** is a variation in air pressure created by a mechanical vibration. For a demonstration of this, lay one of your stereo speakers on the floor, place your hand on it, and turn up the volume. You should feel the speaker vibrate. Now place a piece of paper on the speaker; if the volume is loud enough, you will see the paper vibrate.



You can compare sound waves from your voice to waves in a pond. When you speak the movements in your mouth create sound waves just as tossing a rock into the pond creates water waves. Sound waves travel through air as water waves travel across the pond. If someone is nearby then their ears will feel the pressure variations caused by your sound waves just as a small boat at the other side of the pond will feel the water waves. When you say a word you create a sound wave with energy at various frequencies, just as tossing a handful of various-sized rocks into the pond will create a complicated water wave pattern.



Nearly all sound waves have their energy spread unevenly across a range of frequencies.

Frequency measures how fast something repeats. It is expressed in **Hertz** (Hz, named after Heinrich Hertz for his work in electromagnetism). The range of frequencies that can be heard by the human ear is approximately 16 to 16,000 Hz, and is referred to as the **audio** range.

What is Music? *Music* is when sounds occur in an orderly and controlled manner forming a pattern with their energy concentrated at specific frequencies, usually pleasant to listen to. *Noise* is when the sounds occur in an irregular manner with their energy spread across a wide range of frequencies, usually annoying to hear (static on a radio is a good example). Notice how some people refer to music that they don't like as noise.

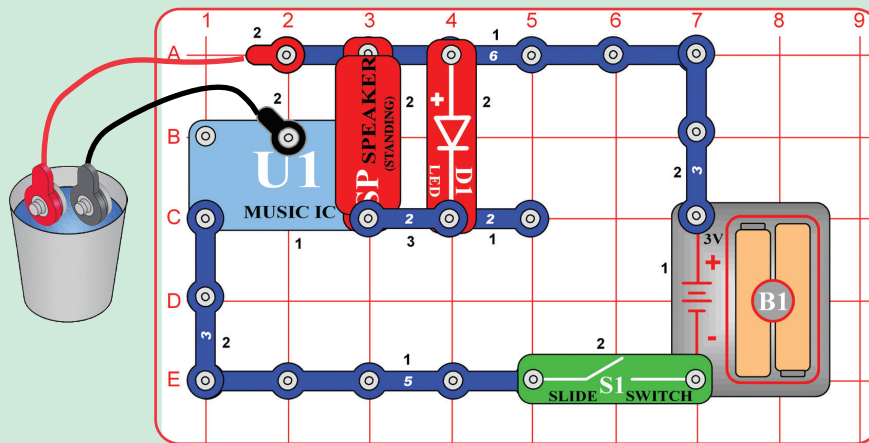
Another way to think of this is that the ear tries to estimate the next sounds it will hear. Music with a beat, a rhythm, and familiar instruments can be thought of as very predictable, so we find it pleasant to listen to. Notice also that we always prefer familiar songs to music that we are hearing for the first time. Sudden, loud, unpredictable sounds (such as gunfire, a glass breaking, or an alarm clock) are very unnerving and unpleasant. Most electronic speech processing systems being developed use some form of speech prediction filters.

The musical world's equivalent to frequency is *pitch*. The higher the frequency, the higher the pitch of the sound. Frequencies above 3000 Hz can be considered to provide *treble* tone. Frequencies about 300 Hz and below provide *bass* tone. *Loudness* (the musical term) or *amplitude* (the electronics term) is increased by simply sending more electrical power to the speaker.

3 - 7 RESISTANCE OF WATER

ACTIVITY 22 SIMPLE WATER ALARM

WARNING: Don't drink any water used here.



Build the circuit as shown, but leave the jumper wires out of the cup of water. Turn on the switch. What happens? _____

Place the ends of the jumper wires in the cup of water. Now what happens? _____

If the alarm did not sound, add 1 teaspoon of table salt to the water. Place the ends of the jumper wires in the salt water. What happens? _____

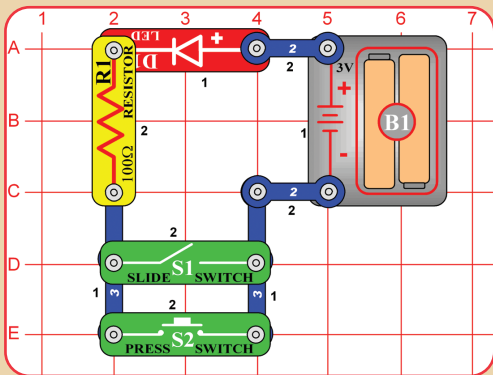
Try holding the ends of the jumper wires with your fingers. Does your body set off the alarm? _____

Are you a conductor or insulator for this circuit that uses only 3 volts? _____

Pure water (like distilled water) has very high resistance, but drinking water has impurities mixed in that lower the resistance. Dissolving salt in water decreases the resistance of the water, so the tone of the alarm may be louder or faster.

3 - 8 INTRODUCTION TO LOGIC

ACTIVITY 23 This OR That OR Both



What are the three positions of the switches that make the LED light up?

Think of all the possible switch positions.

TRUTH TABLE

S1	S2	D1
OFF	OFF	
ON	OFF	
OFF	ON	
ON	ON	

Use the table to determine what happens for each combination. Enter under the heading “D1” the words “ON” or “OFF” for each switch. Position shown on the left. This table is called a “Truth Table”.

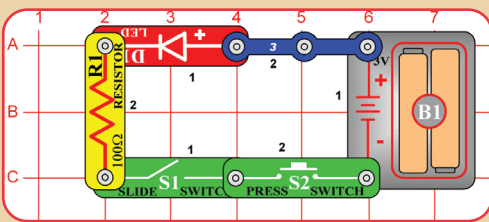
What do you think the name of a circuit with the same truth table would be called?

_____ AND Gate _____ OR Gate
 _____ NOT Circuit _____ IF Gate

This logic is no good for a two way light switch because once one switch is closed the other has no affect on the light. Where would this type of logic be useful in the home? Think about home protection from people that might want to break into your house. _____

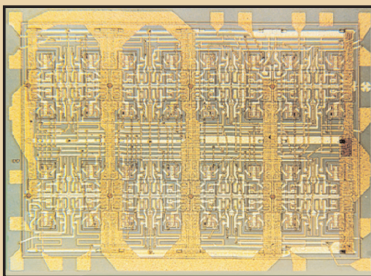
If the slide switch OR the press switch is on, the LED lights up. This is called an OR circuit. While this may seem very simple and boring, it represents an important concept in electronics. Two switches like this may be used to turn on a light in your house. You could also have more than two switches and the circuit would function the same way.

ACTIVITY 24 This AND That



TRUTH TABLE

S1	S2	D1
OFF	OFF	
ON	OFF	
OFF	ON	
ON	ON	



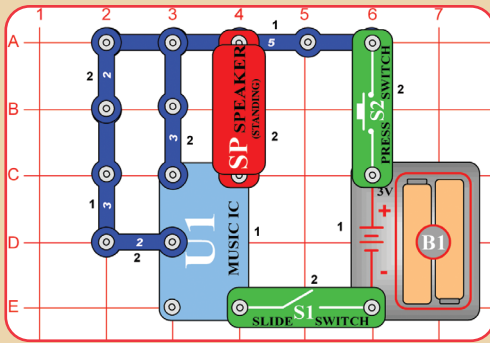
Build the circuit as shown. What do you have to do to make the LED light up? Use the Truth Table to help you with your answer. _____

Is this a series or parallel circuit? _____

Combinations of Logic Circuits and electronic switches are used to add and multiply numbers together in modern computers. The computer circuits are made of tiny transistors in massive integrated circuits. The integrated circuit shown on the left has been enlarged many times to show you the circuits. It's actual size is smaller than the head of a pin.

If the slide switch AND the press switch are on, the LED lights up. This is called an AND circuit. Two switches like this may be used to turn on the same light in your house, the room switch and the master switch in the electrical box.

ACTIVITY 25 Music AND Gate



TRUTH TABLE

S1	S2	D1
OFF	OFF	
ON	OFF	
OFF	ON	
ON	ON	

Build the circuit as shown. What do you need to do to turn on the music? _____

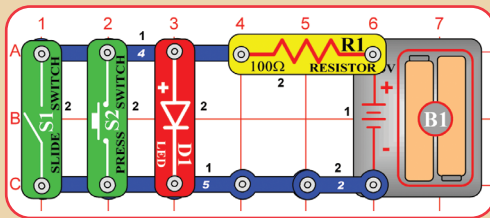
This concept is important in computer logic. If condition X AND condition Y are true, then execute instruction Z.

Let condition X = S1 is ON

Let condition Y = S2 is ON

Let instruction Z = Play Music

ACTIVITY 26 Neither This NOR That



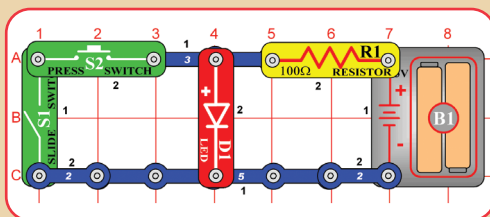
TRUTH TABLE

S1	S2	D1
OFF	OFF	
ON	OFF	
OFF	ON	
ON	ON	

Which combination makes the LED go on? _____

This is called a NOR circuit, which is short for NOT this OR that. Like the OR and AND, it is an important building block in computers. Compare the TRUTH TABLES for the OR and the NOR. What do you notice about the D1 Column? _____

ACTIVITY 27 NOT This AND That



TRUTH TABLE

S1	S2	D1
OFF	OFF	
ON	OFF	
OFF	ON	
ON	ON	

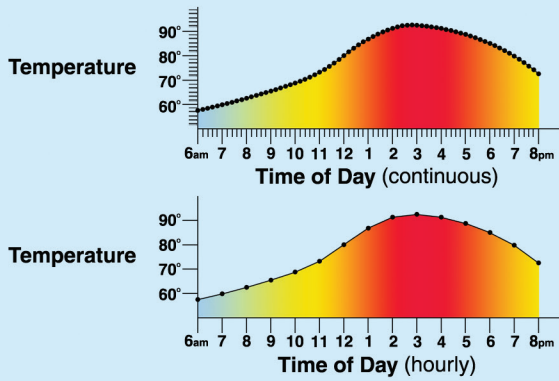
Compare your observations with the AND circuit in activity 26. _____

This circuit is the counter-part to the AND circuit, the LED lights in the opposite combinations of that circuit. It is called a NAND circuit (short for "NOT this AND that"). This circuit can also have more or less than two inputs, though when it only has one input it is referred to as a NOT circuit.

OR, AND, NOR, NAND and NOT circuits are all important building blocks in modern computers.

3 - 9 DIGITAL ELECTRONICS

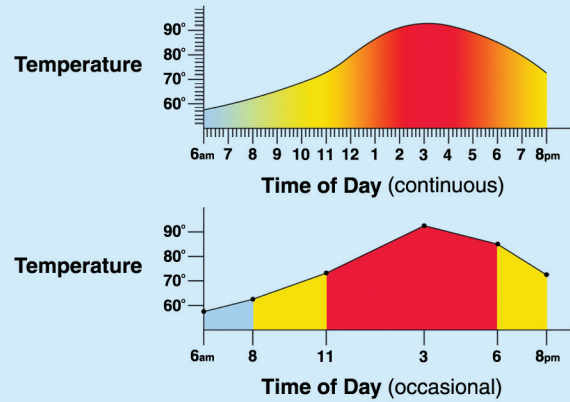
Suppose you wanted to keep a record of how the temperature outside was changing throughout the day. You could use a thermometer to measure it, and watch it continuously or just check it every hour and write it down. Your results might look something like this:



Checking it once an hour gave you a very good record of how the temperature was changing throughout the day, with much less effort than watching it all day long.

Digital electronics uses a series of numbers to represent an electrical signal. If your thermometer was electronic it might increase an output voltage as the temperature increased. It would be hard to store what that voltage was throughout the day, but easy to measure it and store it as a series of numbers. The series of numbers could be converted back into a continuous voltage later.

The accuracy of your digital representation depends on how accurately and how often you measured the original voltage. For example, you could get a better or worse representation of your temperature:



Sometimes it is easier to process information as a digital series of numbers (computers), and sometimes it is easier to use a continuously changing voltage (AM radios). Many products use both methods on the same information but at different times. The disadvantage of digital systems is that they are more complex since they have to store and process all the numbers. The advantages are that IC technology makes it inexpensive to store and process information, and digital systems are more protected from interference.

Computers store numbers in memory using vast arrays of transistors that are switched on or off. The OR, AND, NOR, NAND, and NOT gates are actually made up of transistors. These gates are used to add and multiply large numbers in tiny pieces to form the processing functions in computers.

SUMMARY

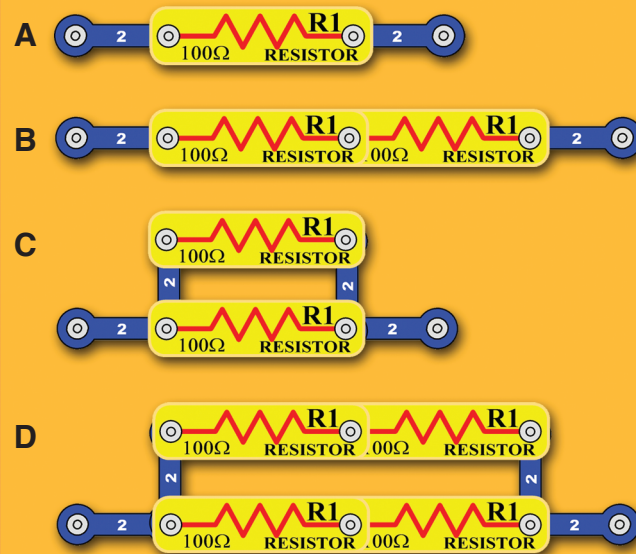
Summary of Chapter 3:

- Resistors are used to limit and control the current in a circuit.
- Resistance is a measure of how much something opposes the flow of electricity in a circuit, and is expressed in ohms.
- Light emitting diodes (LEDs) are one-way, low-current light bulbs. They have a turn-on threshold of about 1.5V.
- Placing resistors in series increases the total resistance. Placing resistors in parallel decreases the total resistance.
- In a circuit, the current equals the voltage divided by the resistance. This is known as Ohm's Law.
- Power measures how much energy is moving through a circuit, it equals the voltage multiplied by the current and is expressed in Watts.
- Materials which have very low resistance are called conductors. Materials which have very high values of resistance and are called insulators.
- Photoresistors change their resistance when light shines on them.
- All currents flowing through resistors produce heat in them.
- OR, AND, NOR, NAND and NOT circuits are basic building blocks of computers.
- Digital electronics uses numbers to represent an electronic signal. The accuracy of the digital representation depends on how accurately and how often the original signal was measured.
- Computers store numbers using arrays of transistors that are switched on or off.
- A speaker uses a changing electrical signal to make variations in air pressure.
- All sounds are variations in air pressure that your ears feel.
- Frequency measures how fast something occurs, and is expressed in Hertz.

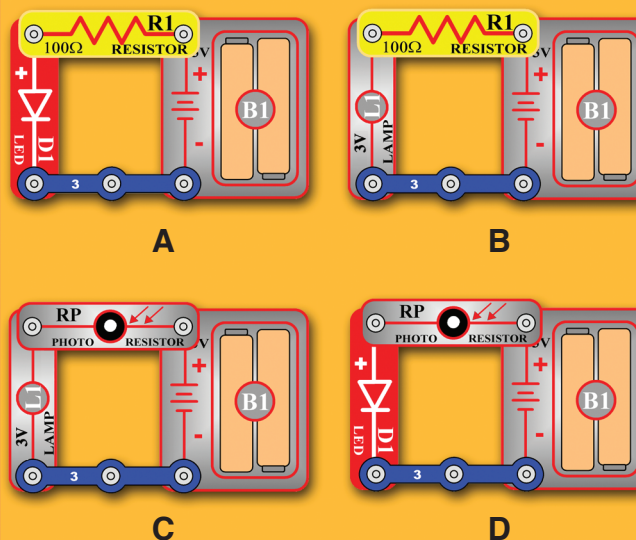
QUIZ

Chapter 3 Practice Problems

- The following are characteristics of an LED except:
 - They block current flow in one direction.
 - They get brighter as current increases.
 - They can handle very high currents.
 - They can emit different colors of light.
- To increase the current through a circuit, you . . .
 - Increase the resistance.
 - Decrease the watts.
 - Increase the ohms.
 - Increase the voltage.
- Which of these sub-circuits will have the lowest resistance? Which will have the highest resistance?



- Which circuit will be the brightest?



Answers: 1. C, 2. D, 3. C/B, 4. A

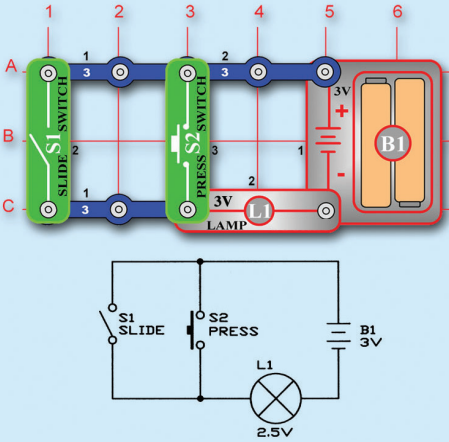
CHAPTER 4: OTHER ELECTRICAL COMPONENTS & CIRCUITS

4 - 1 SCHEMATICS

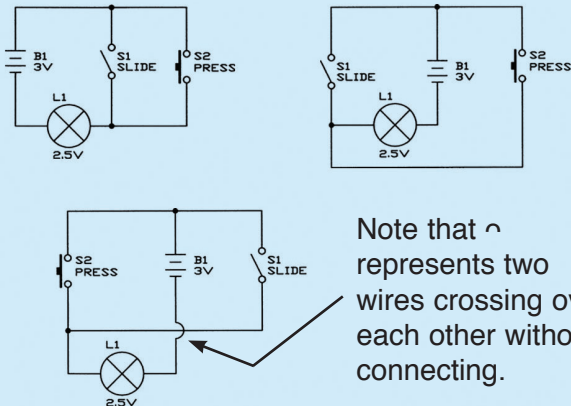
The Snap Circuits® circuit diagrams for the activities are easy to understand and build your circuits from. But what if you wanted to write down your own circuit? These diagrams are not very easy to draw. There are also many ways of building the same circuit. For example, you could use a jumper wire instead of a 2-snap wire.

The Snap Circuits® diagrams give you more information than you really need. They tell you how to build a circuit when all you really need to know is how it will work. You can find your own way to build it.

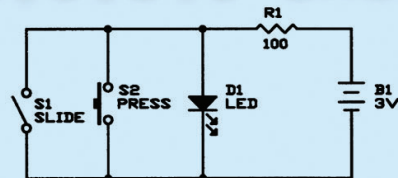
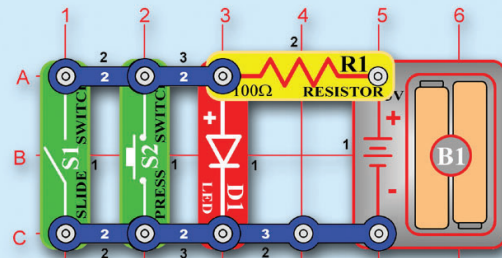
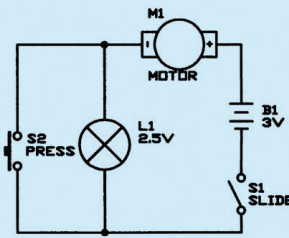
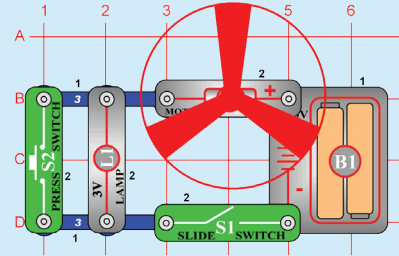
The symbols marked on the parts and introduced in pages 6-8 are used in engineering circuit diagrams, which are called schematics. For example, a simple circuit is shown here with an engineering schematic for it:



Schematics are easy to draw, and the part symbols used are international standards. Note that wires in a schematic are just lines, and can be as long as you like. Schematics are a flexible way of drawing circuits, and can be re-drawn in many different ways. For example, the above schematic could also be drawn as:



Here are some more schematic examples:



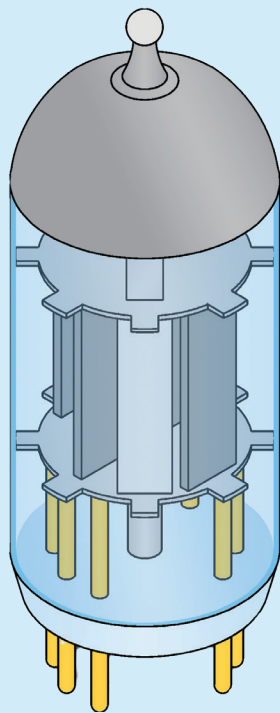
It is important to understand schematics, since many circuit designs are common and can be found in books. Almost all new circuits designed are similar to some circuit that already exists. Many products sold today come with schematics of their designs to assist in troubleshooting problems.

QUICK QUIZ

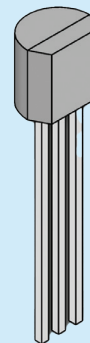
1. Draw a schematic for a circuit that consists of three lamps powered by a battery.
2. For each room in your home, make a schematic drawing showing how the lamps and switches controlling them are connected together.

4 - 2 TRANSISTORS

The invention of the transistor proved to be one of the great discoveries of the 20th century. Originally developed to replace the large and inefficient vacuum tube amplifiers used in early radios, the little transistor is now used in ways its inventors could never have imagined.



Vacuum Tube



Transistor

LEDs and transistors are made from materials called semiconductors, so-called because they have more resistance than metal conductors but less than insulators. Most semiconductors are made of Silicon but Gallium Arsenide is usually used in LEDs. Their key advantage is that by using special manufacturing processes their resistance is decreased under certain operating conditions.

The transistor was first developed in 1949 at Bell Telephone Laboratories, the name being derived from “transfer resistor”. It has since transformed the world. Although it is mostly used in amplifier and switching circuits, engineers have used complex combinations of these circuits to create amazing new technologies.

Improvements in semiconductor manufacturing processes have allowed transistors to be miniaturized, leading to the development of today’s computers. The importance flexibility of transistors should be obvious just by the number of Snap Circuits® projects that use them.

In this chapter you will learn how transistors work, and how they are used in many types of circuits.

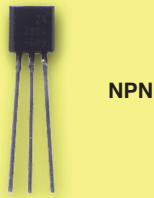
The semiconductor manufacturing processes create two regions of permanent electrical charge, quite different from charging a capacitor. The effect is that once the voltage exceeds a small turn-on level (0.7V for Silicon, 1.5V for Gallium Arsenide LEDs) the resistance becomes very low in one direction (so low that the current flow must be limited by other resistances in the circuit to prevent damage).

The transistor is best described as a current amplifier - it uses a small amount of current to control a large amount of current.

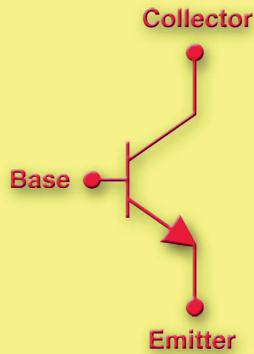
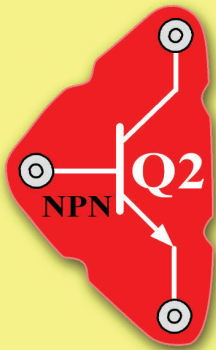
INTRODUCING NEW PARTS

Snap Circuits® includes one NPN-type and one PNP-type transistor, made of the semiconductor silicon. These are the most widely used types of transistors. They have three connection points, called the emitter, base, and collector.

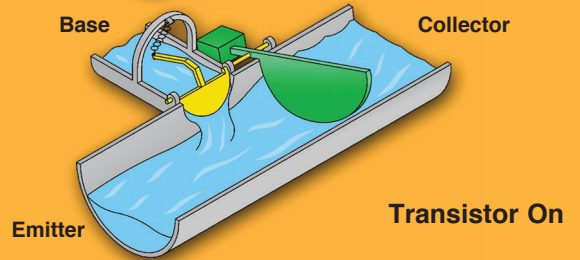
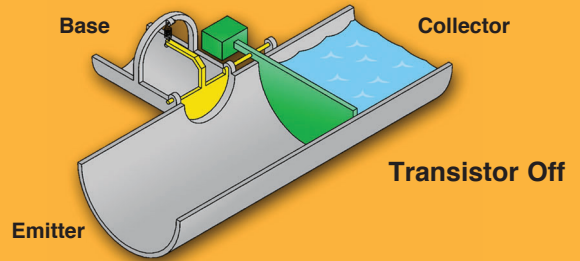
Like LEDs, transistors only allow current to flow in one direction. The small arrow in the symbol near the emitter indicates which direction the current will flow through the transistor.



NPN



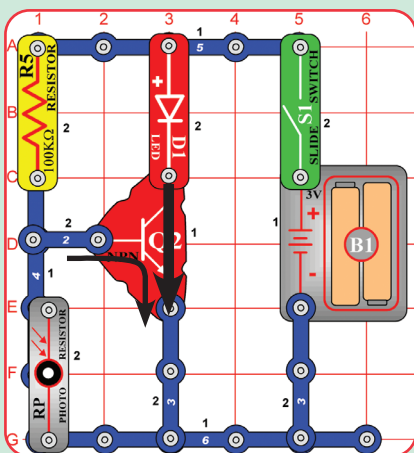
In water pipe terms, the NPN may be thought of as the lever pivot shown here:



Notice that it includes a check valve that is connected to a lever arm. A small amount of current pushes on the check valve, which turns and opens the lever arm. But before this current can start to flow it must have enough water pressure to overcome the spring in the check valve (about 0.7V). If the base pipe is much smaller than the collector and emitter pipes, then a small base current flowing in will allow a large collector current to flow.

In transistors the emitter, base, and collector are different regions of permanent electrical charge, producing the effects described above for the lever pivot. The properties & uses of transistors will become clear after some examples.

ACTIVITY 28 LED Night Light



Build the circuit as shown. Cover the RP Photo Resistor with a piece of paper. Turn the switch on. What happened? _____

Remove the paper over RP and place the unit in the light. What happens? _____

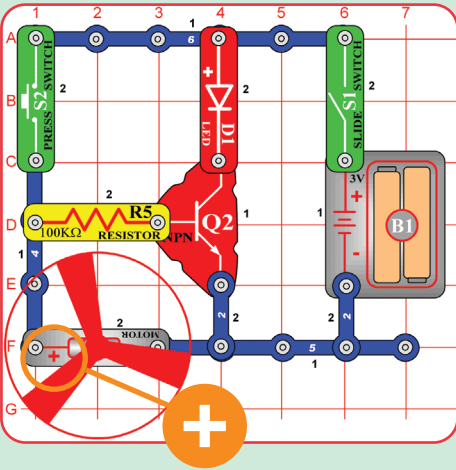
Place the circuit in a dark room. What happens? _____

Turn on the room light. What Happens? _____

Is this circuit similar to an automatic night light? _____

When a small current flows between the transistor base and emitter, a larger (amplified) current flows between the transistor collector and emitter.

ACTIVITY 29 Motor Running LED



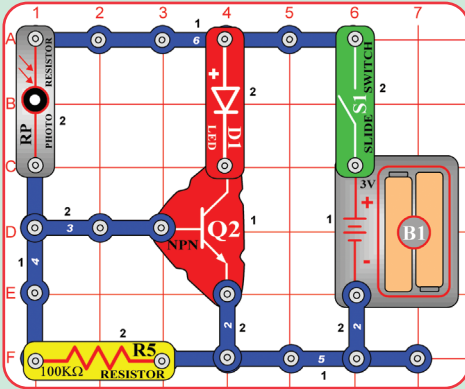
Turn the S1 slide switch on.
Is the LED on? _____ Is the motor running? _____

Push the S2 Push Button Switch.
Is the LED on? _____ Is the motor running? _____

Remove the motor and repeat the experiment. Does the LED act differently? Explain _____

WARNING: Moving parts. Do not touch the fan or motor during operation. Do not lean over the motor.

ACTIVITY 30 Light Activator



Turn on the switch (S1). Does the LED (D1) glow? _____

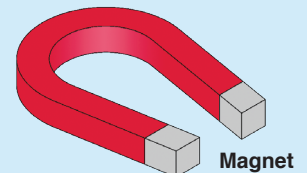
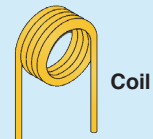
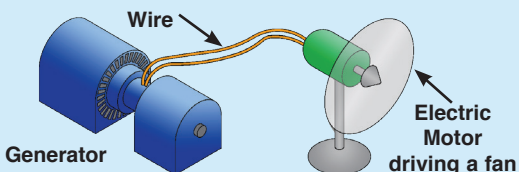
Adjust the light on the photoresistor (RP) by covering with your hand. What happens? _____

4 - 3 ELECTROMAGNETISM

Magnetism is about as important to electricity as butter is to bread. Steam-driven generators produce electricity using magnetism, and electric motors use magnetism to move things. Wires carry the electricity from where it is made to where it is used.

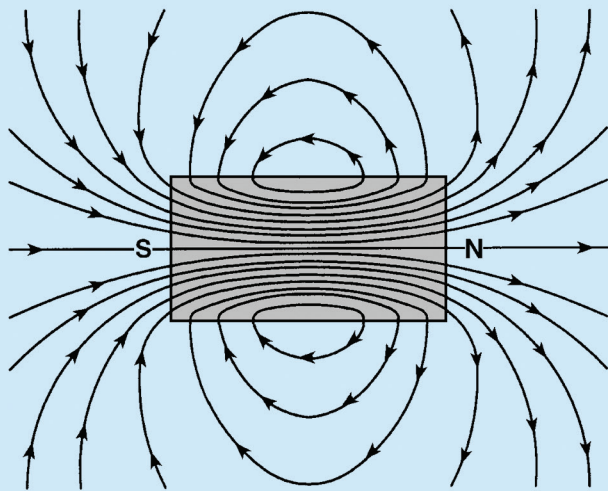
Computer programs are stored on magnetic disks, which store electrical data as magnetic patterns.

In this chapter you will learn about magnetism and how it relates to electricity. Snap Circuits® will show you how electricity can make a magnet. And you will see how electricity can control a magnetic field better than a magnet can.

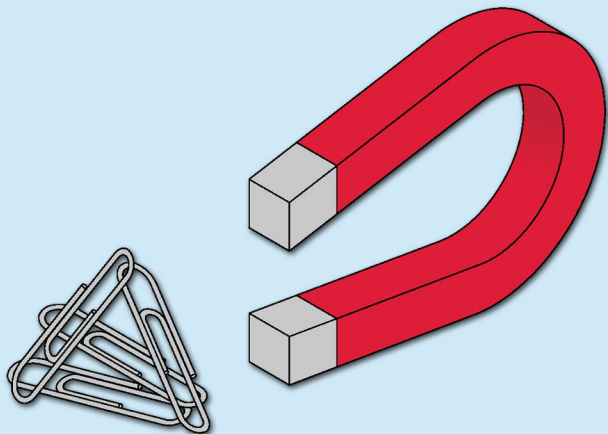


All materials have tiny particles with electric charges, but these are so well balanced that you do not notice them unless an outside voltage disturbs them. The same tiny particles also have magnetic charges, which are usually so well balanced that you do not notice them unless a magnetic field disturbs them.

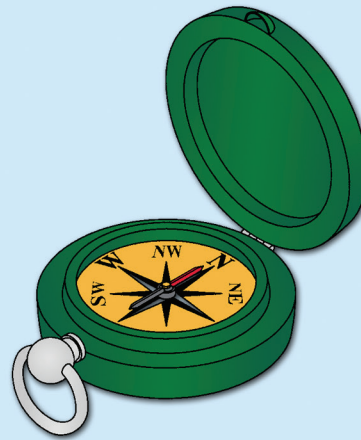
Magnets are materials that concentrate their magnetic charges at opposite ends. One side attracts while the other repels, but the overall material is neutral. Most magnets are made of iron. The name "magnet" comes from magnetite, an iron ore that magnetism was first seen in.



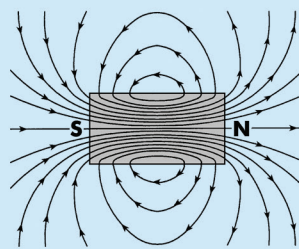
Magnets can magnetize other materials (usually iron), dividing their magnetic charges to opposite ends. This causes the magnetic attraction/repulsion that you see. Magnetization can be temporary or long-lasting, depending on the materials and magnetic force used. For example, paperclips attracted to a magnet sometimes stick together after the magnet is removed. Most magnets can be demagnetized using heat or vibration.



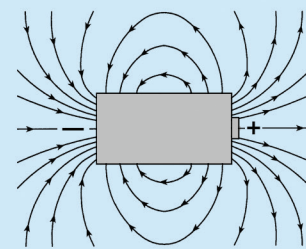
The earth we live on is a giant magnet, due to its iron core. A compass needle always points north because it is attracted to the earth's magnetic field. The opposite ends of a magnet are often labeled north and south, representing the north and south poles of the earth. For centuries ships have used suspended magnets for navigation.



A magnet has a magnetic field, and a battery has an electric field. The north and south poles of a magnet are comparable to the positive and negative terminals of a battery.

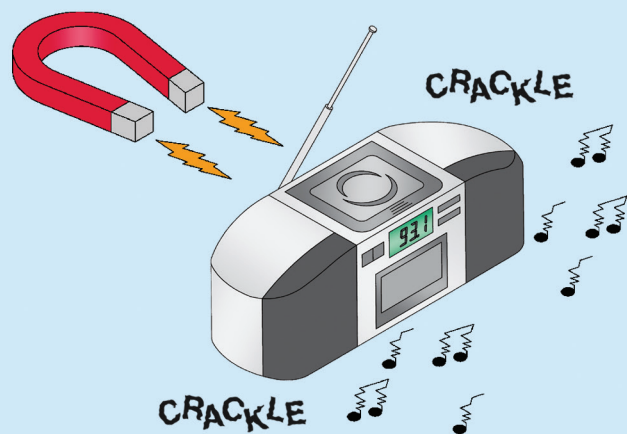


Magnet - magnetic field

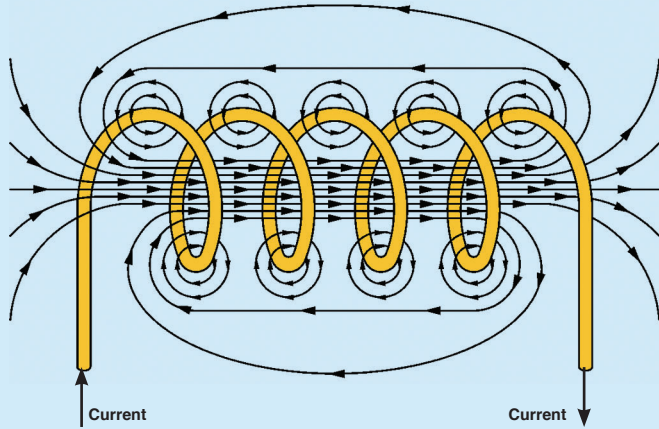


Battery - electric field

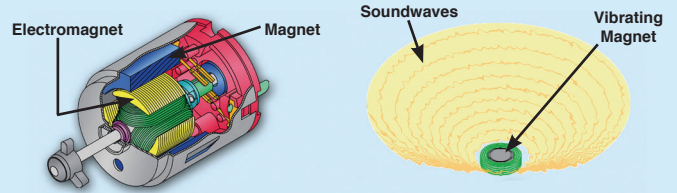
Electric and magnetic fields affect each other. If you place a magnet next to a radio your reception can be disturbed.



In the preceding chapters you learned how electricity uses magnetism to get things done. Remember that an electric current flowing in a wire has a tiny magnetic field. By looping a long wire into a coil the tiny magnetic field is concentrated into a large one.



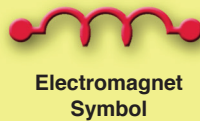
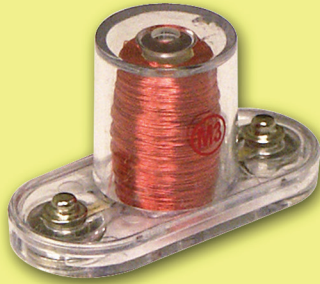
A motor uses a magnetic field to spin a shaft. A transformer creates a current in another circuit using magnetic fields through an iron bar. A speaker uses magnetic fields to create mechanical vibrations, which become sound waves. A relay uses magnetic fields to flip a switch.



All of these create the magnetic field with a current through a coil of wire. But none of these are powerful enough to create a magnetic field like the magnets you have around your house. You need a component that is designed to act like a magnet.

INTRODUCING NEW PARTS

Snap Circuits® includes an electromagnet. If you have the parts with you, then take a look at it; it's just a big coil of wire.

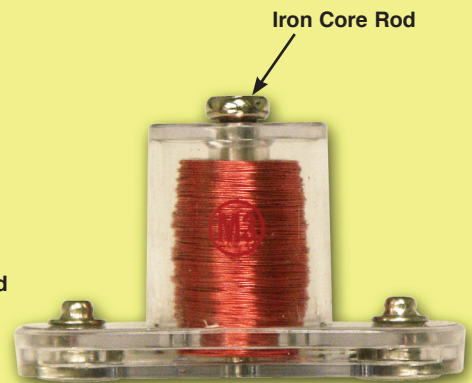


Electromagnet (M3)

Placing an iron rod inside the electromagnet concentrates the magnetic effects. Snap Circuits® includes the Iron Core Rod, which fits neatly inside the electromagnet:

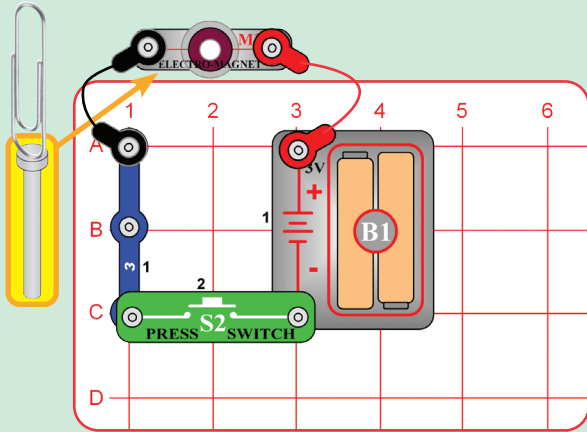


Iron Core Rod

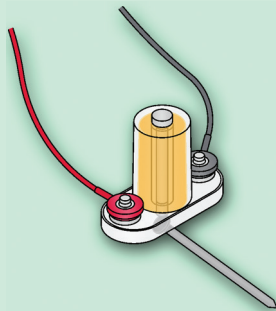


ACTIVITY 31 THE ELECTROMAGNET

You can use Snap Circuits® to see how electricity makes magnetism. Place the iron core rod inside the electromagnet, hold it next to something iron like a pair of scissors, a hammer, or refrigerator. You won't notice any attraction.



Build the circuit as shown, and place the iron core rod in the electromagnet (M3). Push the switch (S2) and touch the paper clip to the iron core rod in the electromagnet. Let go of the paper clip so only the magnet holds the paper clip in place. Release the switch (S2) to stop the flow of current.



What happens to the paper clip when the current is turned off? _____

How is an electromagnet like a permanent magnet? _____

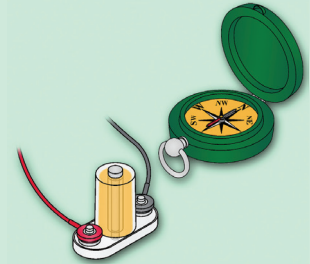
How is an electromagnet different than a permanent magnet? _____

How are electromagnets used in real life? _____

Current flowing in a wire creates a magnetic field around the wire. The field is increased when the wire is made into a coil. If a piece of iron, such as a nail or rod, is inserted into the coil it makes the magnetic field stronger. With the wires attached and the iron core rod inside, place the electromagnet next to the same iron objects and press the switch.

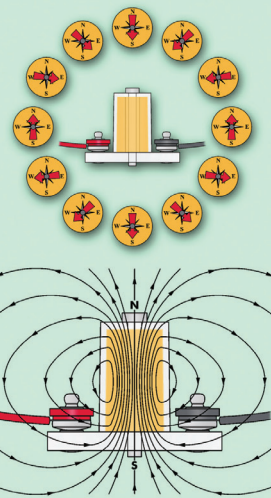
The electric current through the coil turns the iron core rod into a magnet. It sticks to a refrigerator or hammer but lets go when you release the switch. You can use it to pick up nails and drop them.

The electromagnet has more power when the batteries are new, so replace them for best results. Don't press the switch continuously, or you will quickly drain your batteries.



An electronic magnet has a magnetic field just like an ordinary magnet. If you have a compass, you can look at the magnetic field using the same circuit (project 660). Hold your compass next to the electromagnet and press the switch.

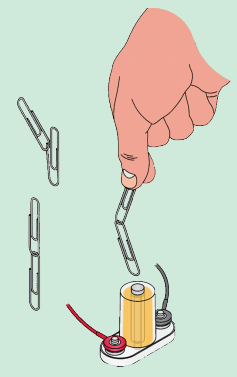
Move the compass all around the electromagnet and watch where the compass points.



The iron core rod concentrates the magnetic effects. Remove the rod and hold the compass next to the electromagnet again. The attraction is now very weak.

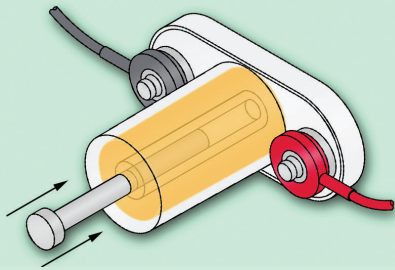
If you don't have a compass, you can make one using metal paperclips. Slide two paperclips together, using their loops.

Hold the paperclips just above the electromagnet, without them touching the iron core rod. Press the switch and watch how the lower paperclip is attracted to the rod. It will point toward it like a compass.



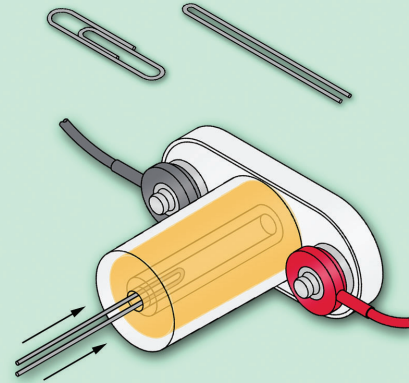
ACTIVITY 32

Lay the electromagnet on its side with the iron core rod sticking out about halfway. Press the switch to see the rod get sucked into the center.



A lighter iron object will move better. Straighten out a paperclip, and bend it in half.

Place it on one side of the electromagnet and press the switch to see it sucked inside. Hold the switch and gently pull it out to see how much suction the electromagnet has.



Try sucking in other thin iron objects, like nails.

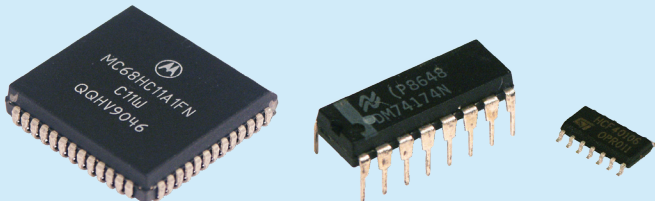
Materials made of iron concentrate their magnetic effects at both ends. The center of the material is magnetically neutral because the attraction from each end is the same.

The magnetic field created by the electromagnet works the same way. It is strongest at both ends but neutral in the center. But the electromagnet is hollow - so iron at one end will be sucked into the middle.

4 - 4 INTEGRATED CIRCUITS

A key advantage of semiconductors is that several transistors can be manufactured on a single piece of silicon. This led to the development of Integrated Circuit (IC) technology around 1960. In ICs, careful control of complex manufacturing processes has enabled entire circuits consisting of transistors, diodes, resistors, and capacitors to be constructed on a silicon base. IC manufacturing is so specialized that particles of dust can render parts useless.

Many thousands of parts now fit into an area smaller than your fingernail. In fact, some ICs used in computers now have more than a million transistors



on them, and a drawing of everything on them would be huge. Spectacular improvements in cost, size, and reliability have been achieved as a result.

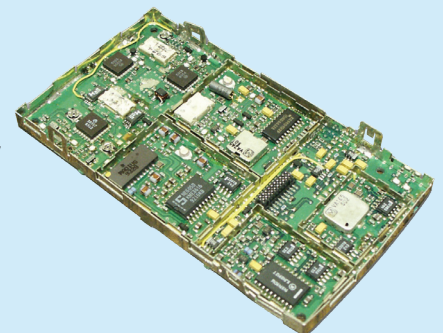
Further research led to the development of microprocessor ICs, which can do many different tasks based on programming that can be easily changed. The leader of Intel Corporation once

boasted that the speed of the newest microprocessors doubled every eighteen months. This came to be known as Moore's Law, and held true for more than a decade.

Integrated circuits are used in everything from simple electronic toys to the most advanced computers. Many technologies would not have been possible without them. A cellular phone, for example, is an extremely complex device that has been so miniaturized with ICs that it fits in your hand.

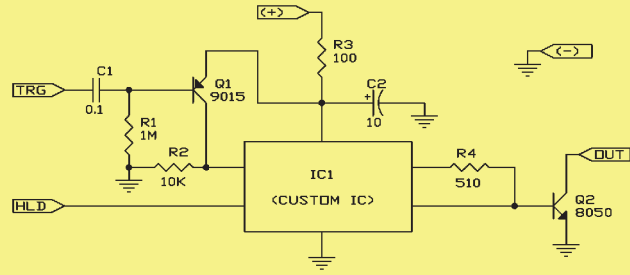
In this chapter you will learn about the integrated circuit modules included in Snap Circuits®, and have the opportunity to make many types of circuits using them. But first you will learn about electronic sound.

Your electronic stereo and radio are powered by electricity and play music, so how does electricity make sound? In this chapter you will find out.

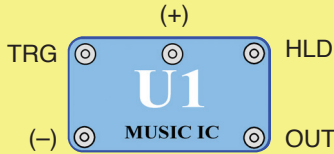


INTRODUCING NEW PARTS

The **music IC** module contains sound-generation ICs and supporting components. It can play one or more musical tunes that are recorded in it. Its actual schematic is complex and looks like this:



Its Snap Circuits® connections are like this:



Music IC:

(+) - power from batteries
 (-) - power return to batteries
 OUT - output connection

HLD - hold control input
 TRG - trigger control input

Music for ~20 sec on power-up, then hold HLD to (+) power or touch TRG to (+) power to resume music.

This module has two different control inputs. The OUT connection pulls current into the module (not out of it), usually from a speaker. This current is adjusted to make the music.

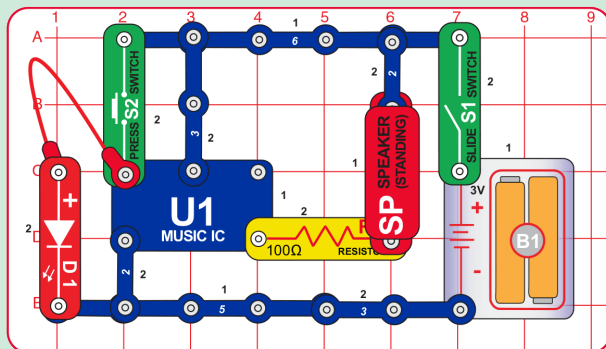
QUICK QUIZ

1. Select an electronic product in your home and guess how many ICs are inside it. Then (with the power disconnected from it) open it and look to see how many there are.

ACTIVITY 33 Musical Doorbell

Use the circuit diagram symbols to draw the circuit shown below.

Circuit Diagram



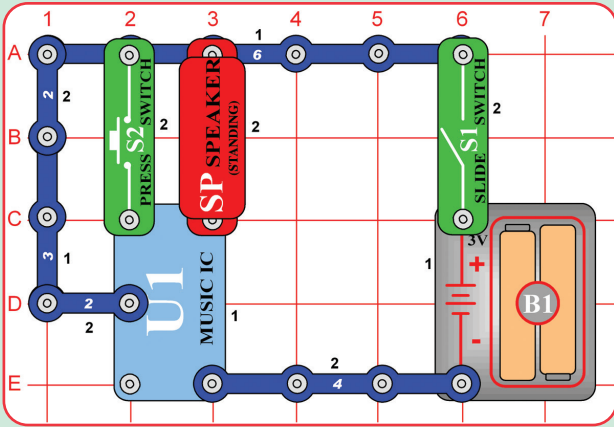
When you close the slide switch, what happens? _____

To simulate a doorbell, push the button on the press switch.

Do you need to hold the button down to keep the music playing? _____

What kinds of toys do you think could have integrated sound circuits? _____

ACTIVITY 34 Musical Alarm



When you close the slide switch, the music integrated circuit should play one song and then stop.

Is this louder or softer than the music in activity 33?
 Why? _____

How are the circuits in activity 33 and 34 different? _____

What happens when you hold the press switch down?

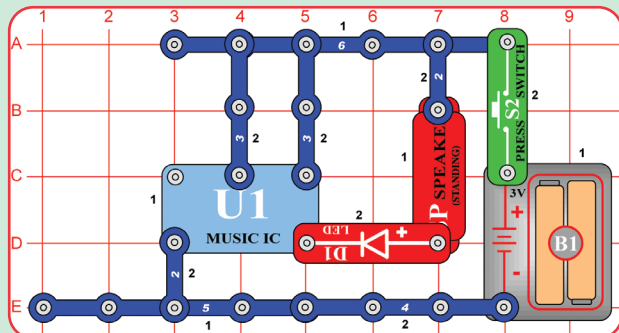
What happens when you release the press switch? _____

What can you do to keep the song playing? _____

ACTIVITY 35 Happy Birthday with Light

Use the circuit diagram symbols to draw the circuit shown below.

Circuit Diagram

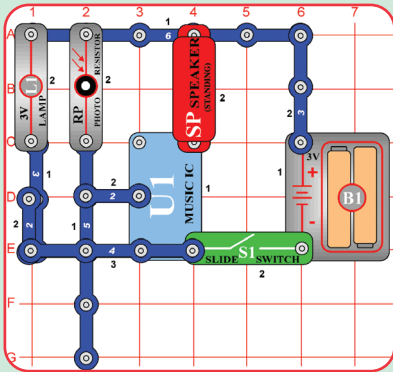


What happens when you push the press switch? _____

How can you change the length of time the Song & LED stay on?

Are the LED and Speaker connected in series or in parallel?

ACTIVITY 36 Reflection Detector



Build the circuit as shown. Place it where there will be no room light hitting the photoresistor (RP), such as under a piece of paper, or under the table. Turn on the switch. What happened? _____

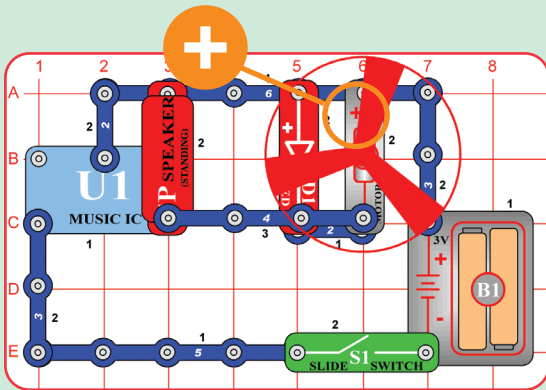
Take a small mirror and hold it over the lamp and photoresistor (RP). Try and reflect the light from the bulb into the top RP hole. What happened? _____

You have made a reflection detector. What happens as more light is reflected onto the photoresistor? _____

Use a white card or piece of paper to reflect light instead of the mirror. What do you think will happen? _____

Try the card as a reflector. What happened? _____

ACTIVITY 37 Sounds, Light, and Motion




Build the circuit as shown, with the “+” side of the motor (M1) on top. Turn on the slide switch. What happens? _____

When the sound stops, what happens? _____

Are the sound, light, and motion circuits connected in series or parallel? _____

What happens when you remove the 4 snap wire on level 3 and why? _____

Explain what you think are the functions of the various components in this circuit. _____

WARNING:
 Moving parts. Do not touch the fan or motor during operation. Do not lean over the motor

SUMMARY

Summary of Chapter 4:

1. Schematics are engineering drawings of circuits using symbols.
2. The resistance of semiconductors may be controlled by their operating conditions.
3. Semiconductors have a turn-on level (0.7V for silicon), after which the resistance becomes very low in one direction.
4. Transistors have three connection points, called the emitter, base, and collector.
5. The transistor is a current amplifier, it uses a small amount of current to control a large amount of current.
6. When a small current flows into the base and out of the emitter in an NPN transistor, a larger current flows into the collector and out of the emitter.
7. Magnets are materials that concentrate their magnetic fields at opposite ends.
8. An electric current flowing in a coil of wire has a magnetic field.
9. Placing an iron rod inside a coil of wire increases the magnetic effects from a current flowing through the wire.
10. Electricity can use magnetism to move things, and can control magnetic fields in ways ordinary magnets can't.
11. Integrated Circuits are miniature circuits with many transistors, resistors, capacitors, and wires all made on a semiconductor base.

QUICK QUIZ

1. In a transistor, the _____ will have the most current flowing through it.
A. Emitter C. Collector
B. Base D. Vacuum tube
2. Which of these would be attracted to an electronic magnet?
A. A plastic paperclip C. An iron screw
B. A wooden toothpick D. A resistor
3. How can you increase the magnetic field from the electromagnet?
A. Increase the current through the electromagnet.
B. Remove the iron core rod from the electromagnet.
C. Place a resistor in series with the electromagnet.
D. Decrease the current through the electromagnet.
4. Which of these is an advantage of using an electromagnet instead of an ordinary magnet?
A. An electromagnet can attract materials that aren't attracted to ordinary magnets.
B. An electromagnet can be used as a compass.
C. You can turn the magnetic field on and off quickly by controlling the current through an electromagnet.
D. None of the above.
5. The following parts can be built into an integrated circuit except:
A. Diodes B. Switches
C. Resistors D. Transistors
6. Which of these electrical products is least likely to have an integrated circuit in it?
A. Lamp B. Garage door opener
C. Car D. Radio
7. Which of the following are advantages of integrated circuits?
A. Size B. Reliability
C. Cost D. All of the above

Answers: 1. A, 2. C, 3. A, 4. C, 5. B, 6. A, 7. D

DEFINITION OF TERMS

AC	Common abbreviation for alternating current.	Direct Current	A current that is constant and not changing.
Alternating Current	A current that is constantly changing.	Electric Charge	An electrical attraction/ repulsion between materials.
Ampere (A)	The unit of measure for electric current.	Electrical Power	A measure of how much energy is moving in a wire.
Amplify	To make larger.	Electricity	An attraction and repulsion between sub-atomic particles within a material.
Amplitude	Strength or level of something.	Electromagnetic	Involving both electrical and magnetic effects.
Analogy	A similarity in some ways.	Electronics	The science of electricity and its applications.
Audio	Electrical energy representing voice or music that can be heard by human ears.	Emitter	One of the connection points on a transistor.
Base	One of the connection points on a transistor.	Filament	A high-resistance wire used in incandescent light bulbs.
Battery	A device which uses a chemical reaction to create an electric charge across a material.	Fluorescent Lamp	A lamp that creates light using a glowing gas.
Blackout	When part of a city is cut off from the power plants supplying it with electricity.	Frequency	The rate at which something repeats.
Circuit	An arrangement of electrical components to do something.	Friction	The rubbing of one object against another. It generates heat.
Clockwise	In the direction in which the hands of a clock rotate.	Fuse	A device used to shut off a circuit when excessive current is drawn.
Coil	A wire that is wound in a spiral.	Gallium Arsenide	A chemical element that is used as a semiconductor.
Collector	One of the connection points on a transistor.	Generator	A device which uses steam or water pressure to move a magnet near a wire, creating an electric current in the wire.
Color Code	A method for marking resistors using colored bands.	Ground	A common term for the 0V or “-” side of a battery or generator.
Conductor	A material that has low electrical resistance.	Incandescent Lamp	A lamp that creates light using a material that is heated until it glows.
Counter-Clockwise	Opposite the direction in which the hands of a clock rotate.	Inductance	The ability of a wire to create an induced voltage when the current varies, due to magnetic effects.
Current	A measure of how fast electricity is flowing in a wire or how fast water is flowing in a pipe.	Inductor	A component that opposes changes in electrical current.
DC	Common abbreviation for direct current.	Insulator	A material that has high electrical resistance.
Digital Circuit	A wide range of circuits in which all inputs and outputs have only two states, such as high/low.	Integrated Circuit	A type of circuit in which transistors, diodes, resistors, and capacitors are all constructed on a semiconductor base.
Digital Electronics	Using a series of numbers to represent an electrical signal.		
Diode	An electronic device that allows current to flow in only one direction.		

DEFINITION OF TERMS

Kilo- (k)	A prefix used in the metric system. It means a thousand of something.		that uses symbols for all the components.
LED	Common abbreviation for light emitting diode.	Semiconductor	A material that has more resistance than conductors but less than insulators. It is used to construct diodes, transistors, and integrated circuits.
Light Emitting Diode	A diode made from gallium arsenide that has a turn-on energy so high that light is generated when current flows through it.	Series Circuit	When electrical components are connected one after the other.
Lightning	A discharge of static electricity between a cloud and the ground.	Short Circuit	When wires from different parts of a circuit (or different circuits) connect accidentally.
Lightning Rod	A metal rod between the roof and ground, used to protect houses from lightning.	Silicon	The chemical element most commonly used as a semiconductor.
Magnetic Field	The region of magnetic attraction or repulsion around a magnet or an AC current.	Solder	A tin-lead metal that becomes a liquid when heated to above 500°F. It makes a strong mounting that can withstand shocks.
Magnetism	A force of attraction between certain metals. Electric currents also have magnetic properties.	Speaker	A device which converts electrical energy into sound.
Milli (m)	A prefix used in the metric system. It means a thousandth (0.001) of something.	Static Electricity	A naturally occurring build-up of electrical charge between materials, usually at high voltage.
Modulation	Methods used for encoding signals with information.	Switch	A device to connect (“closed” or “on”) or disconnect (“open” or “off”) wires in an electric circuit.
Motor	A device which converts electricity into mechanical motion.	Transformer	A device which uses coils to change the AC voltage and current (increasing one while decreasing the other).
NPN	A type of transistor construction.	Transistor	An electronic device that uses a small amount of current to control a large amount of current.
Ohm’s Law	The relationship between voltage, current, and resistance.	Tungsten	A highly resistive material used in light bulbs.
Ohm, (Ω)	The unit of measure for resistance.	Voltage	A measure of how strong an electric charge difference between materials is.
Parallel Circuit	When several electrical components are connected between the same points in the circuit.	Volts (V)	The unit of measure for voltage.
Pitch	The musical term for frequency.	Watt (W)	The unit measure for electrical power.
Polarity	Markings indicating which direction a device is positioned in, usually (+) and (-).		
Printed Circuit Board	A board used for mounting electrical components. Components are connected using metal traces “printed” on the board instead of wires.		
Resistance	The electrical friction between an electric current and the material it is flowing through.		
Resistor	Components used to control the flow of electricity in a circuit.		
Schematic	A drawing of an electrical circuit		

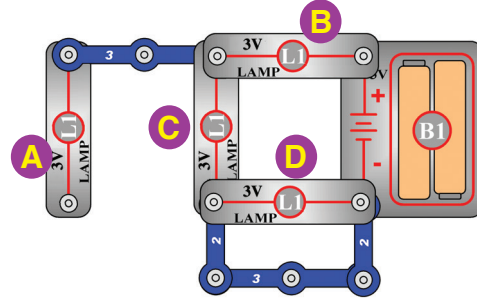
TEST YOUR KNOWLEDGE

Name _____

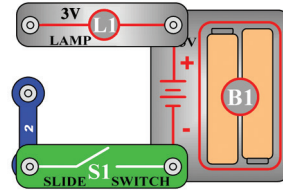
Date _____

1. Look at the four circuit diagrams.

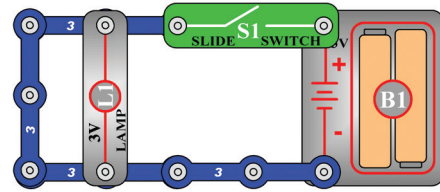
A. Which bulbs will light up?



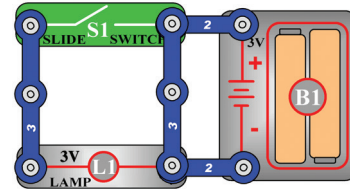
B. What could you do to repair this circuit?



C. What could you do to repair this circuit?



D. What could you do to repair this circuit?



2. What is a circuit?

3. What does a switch do in a circuit?

4. What is the function of the battery in a circuit?

5. In a series circuit with a motor and a lamp will the motor spin faster with or without the lamp?

6. Label each of the following items as a conductor or an insulator.

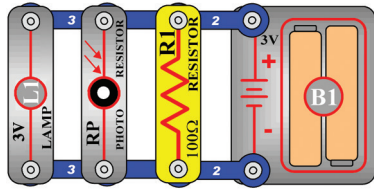
<u>Material</u>	<u>Conductor or Insulator</u>	<u>Material</u>	<u>Conductor or Insulator</u>
Steel nail		Pencil lead	
Brass fastener		Rubber eraser	
Piece of chalk		Cardboard strip	
Plastic straw		Wooden craft stick	
Penny coin		String	
Strip of aluminum foil		Coated paper clip	

7. What do all of the conductors have in common?

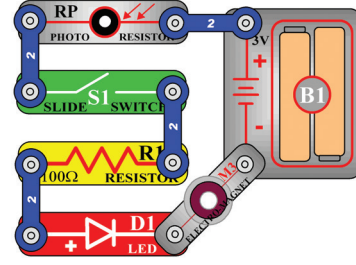
8. List two uses for insulators in everyday life.

9. Label the following four circuits as series or parallel.

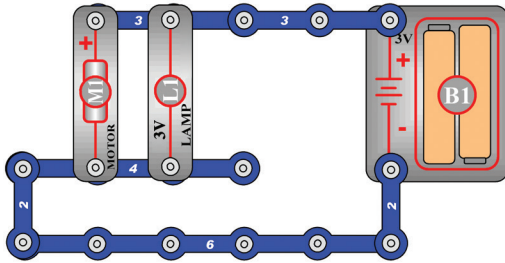
A.



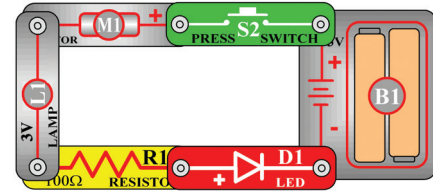
B.



C.



D.



10. If a lamp and a motor are in the same series circuit, how does the resistance of the motor affect the brightness of the lamp?

11. Does placing an iron rod inside an electromagnet increase or decrease the magnetic effects?

12. List 3 uses for electricity in your life.

a.

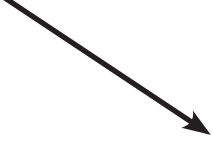
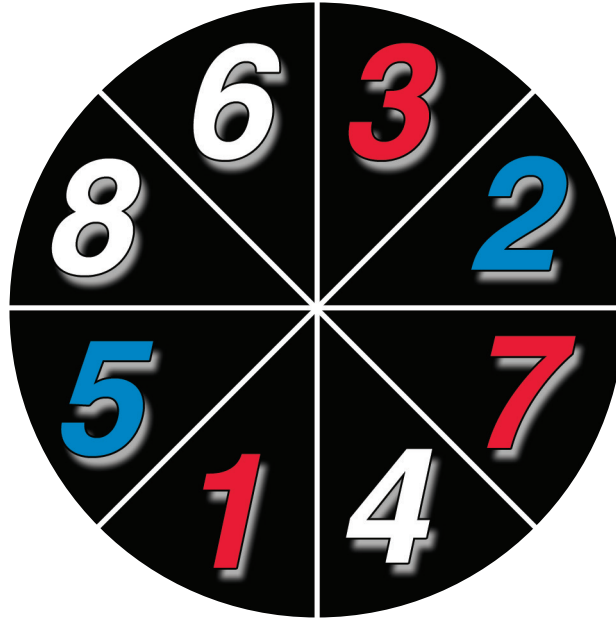
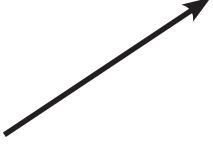
b.

c.

Page 22 for
Activity 16



Page 29 for
Activity 25





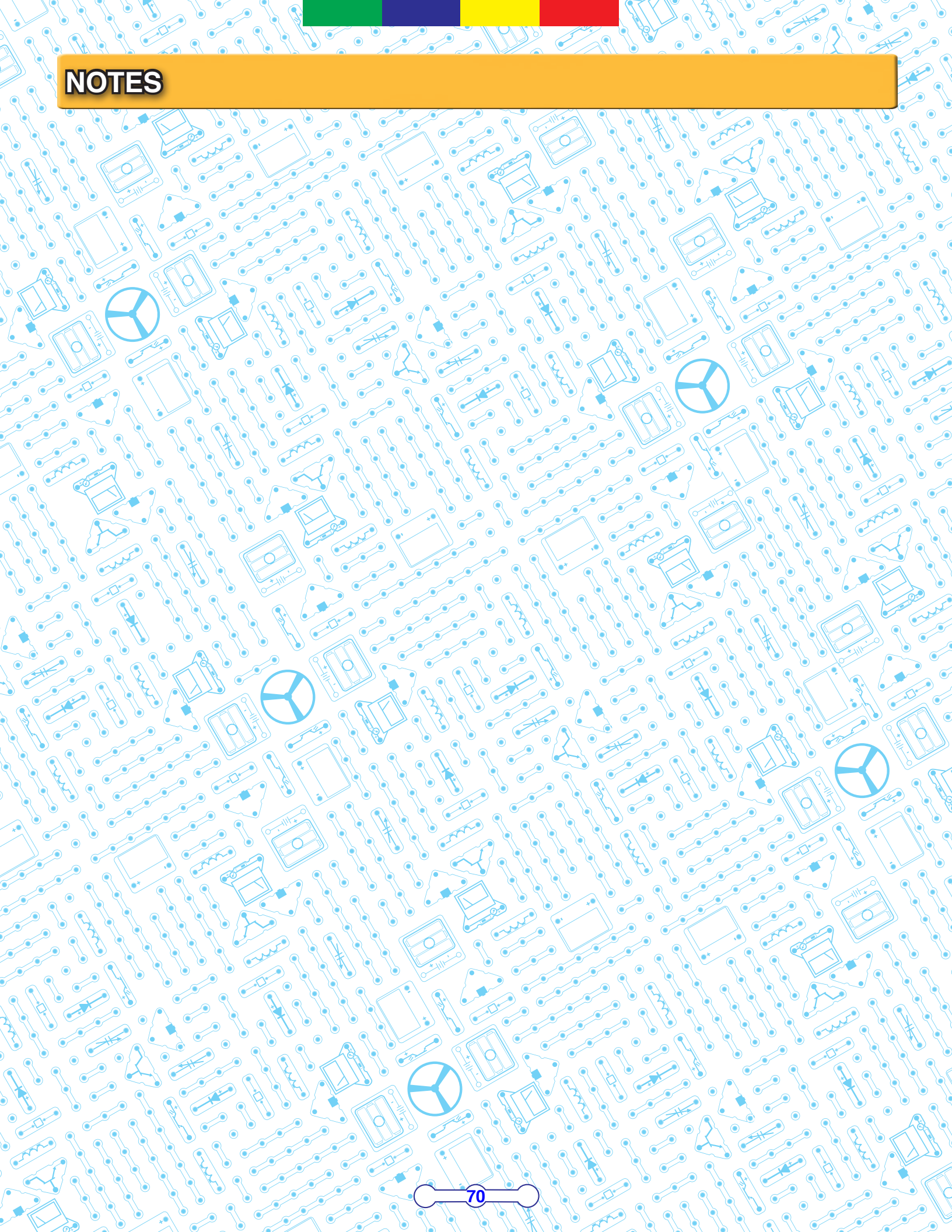
NOTES



NOTES



NOTES



2

3

3

3

3

3

3

3

4



ELENCO
Learn by doing.®

150 Carpenter Ave.
Wheeling, IL
60090 USA

Find more fun at
Elenco.com

